

FOUNDATION REQUIREMENTS

ALL FOUNDATION SPECIFICATIONS SHALL BE CONSTRUED AS RECOMMENDATIONS ONLY. BECAUSE OF THE MANY VARIABLE CONDITIONS IN AN ACTUAL INSTALLATION, GRAIN SYSTEMS, INC. ASSUMES NO LIABILITY FOR RESULTS ARISING FROM THE USE OF SUCH RECOMMENDATIONS.

SITE PREPARATION

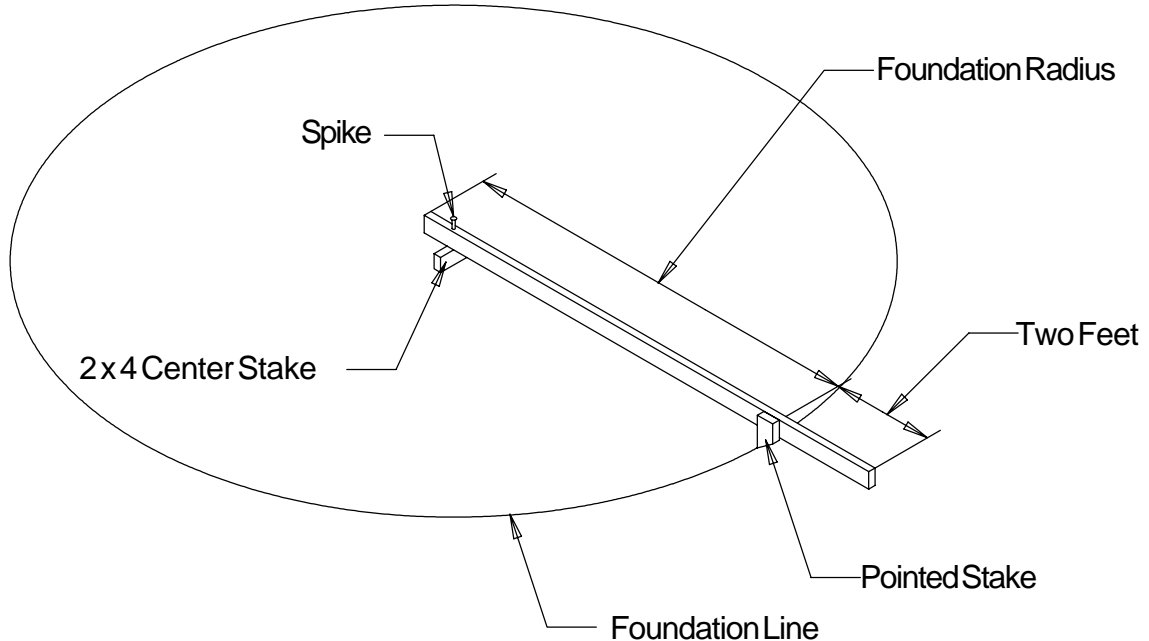

Figure #1

1. SELECTING THE PROPER SITE

The selected site should be level, firm, and free from underlying debris. The bin can be installed satisfactorily on slopes, but as the slope increases, additional labor and materials are required for the foundation. The concrete foundation surface must be level. If some fill is required, it should be watered and tamped thoroughly to prevent uneven settling from the weight of the bin. Naturally, the site must allow convenient access for easy loading and unloading, plus provide additional space for future units. Also, consider the positioning of handling equipment, availability of electricity, and the placement of fans, heaters, and gas tanks.

2. SCRIBE THE DIAMETER

Having determined the center of the site, drive a small 2 x 4 in the ground to mark the center point of the foundation. The top of the stake should be the same height as the finished foundation will be. Using one large spike, nail a straight 2 x 4 (approximately 2 feet longer than the radius of the bin) to the top of the center stake. This will enable it to swivel. Along the opposite end at a distance given in the foundation layout table, attach a sharply pointed stake. The swiveling 2 x 4 will act as a compass, enabling you to scribe the correct diameter of your foundation and later locate the anchor and stiffener bolt locations. (NOTE: Making the 2 x 4 two feet longer than the radius will allow the 2 x 4 to also be used as a leveling device and for pulling concrete.)

CIRCULAR FOUNDATION FORM

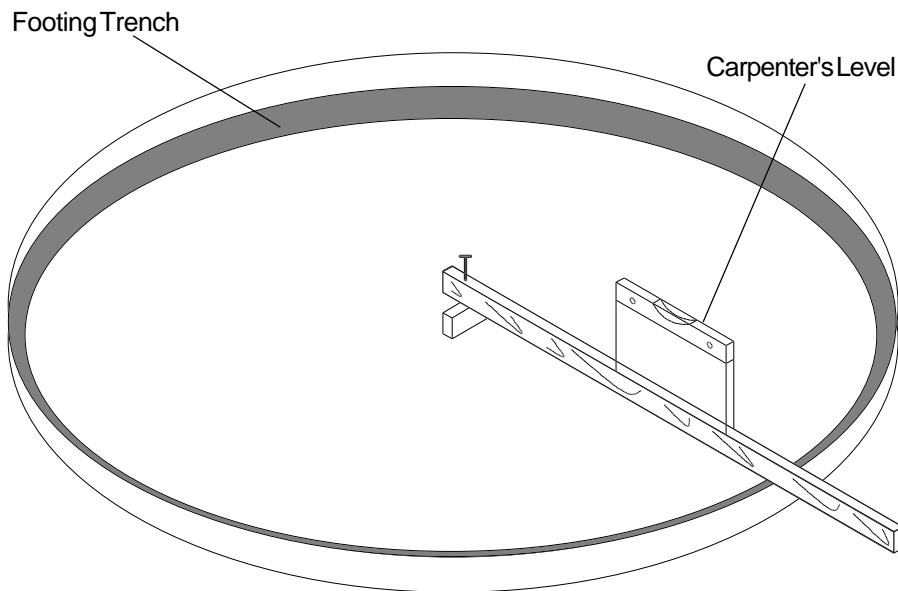

Figure#2

3. PREPARE THE FOUNDATION

Having scribed the diameter of your foundation, proceed by digging the footing of the foundation. This consists of a large circular trench dug just inside the foundation line. (Refer to foundation details for necessary information.) Once the footing has been dug, you are ready to build the forms. It is important that your form be rigid enough to hold its shape against the poured concrete. Also, the foundation must be flat. Sloped floors cannot be used in drying bins. A carpenter's level placed on top of your 2 x 4 will enable you to set the top of the forms to match the top of the center stake. Check the form work with a transit to ensure a uniform elevation for the entire foundation.

OCTAGONAL FOUNDATION FORM

There are two styles of foundation forms commonly used. The first is the circular form depicted in Figure #2. The second style can be made of 2" x 8" boards set into a square with corners blocked off to form an octagon. (See Figure #3 below.) This eight sided form will approximate a circle and can be constructed quite easily.

When the foundation form is completed install reinforcement rods by either welding or wiring in place. Place 2" of compacted sand on the inside level of the foundation. The sand is then covered with a 4 mil plastic moisture barrier. 6" x 6" wire mesh (2 mats), covering the entire area of the foundation, completes your preparation of the bin's foundation. You are now ready to begin pouring concrete.

NOTE: ALL CONCRETE IS TO HAVE A MINIMUM COMPRESSIVE STRENGTH OF 3,000 PSI @ 28 DAYS.

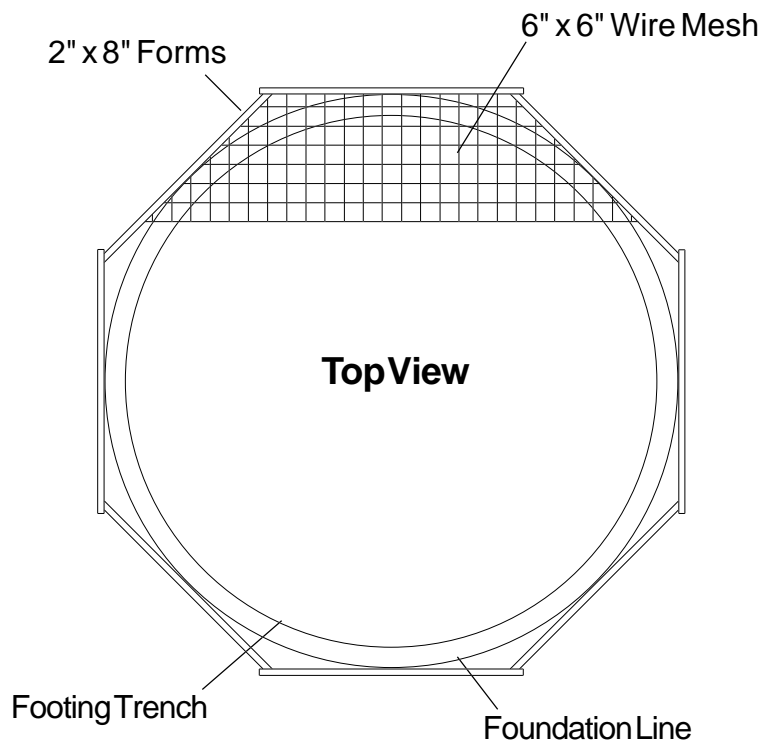

Figure #3

FROST FREE PAD

NOTES:

- Foundation site should be well drained and free of vegetation or debris.
- Foundation design is based on a minimum soil bearing capacity of 3,000 lb/ft². If soil bearing capacity is in doubt, contact a local soil testing engineer.
- Concrete shall have a minimum compressive strength of 3,000 PSI at 28 days.
- Requirements for reinforcement do not include overlap.
- Lap all circumferential bars 35 bar diameters and stagger all laps in plan 3'-0".
- All material used for back fill inside the ring wall should be a clean, well graded, crushed stone or sand-gravel mixture. Back fill should be placed in 6" lifts and well compacted.

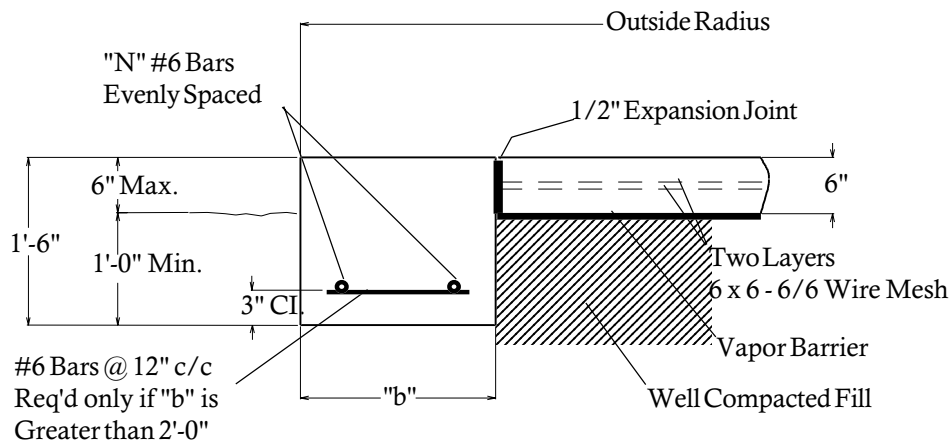

Figure #4

24' Diameter Bin

Ring Number	4	5	6	7
b	1'-1"	1'-1"	1'-9"	1'-9"
N	2	2	2	2
Outside Radius	12'-9"	12'-9"	12'-9"	12'-9"
Sq. Ft. Mesh 6 x 6 - 6/6	900	900	900	900
Length of #6 Bars	200	200	200	200
Total Cubic Yd. Concrete	13	13	15	15

ANCHOR BOLT LAYOUT

Refer to following diagram for proper bolt layout.

Having poured and leveled the concrete, use the center stake and straight 2" x 4" again to find bolt circle radius for the outside stiffener bolts. Select a starting point and stretch a pre-measured chord along the imaginary circle formed by the bolt circle radius. Consider the placement of these bolts so as not to interfere with the positions of bin doors and transitions.

Work both directions from first anchor bolt location, this will help eliminate possible error in laying out anchor bolts. On larger bins sight across starting anchor bolt and center pin and place anchor bolt on opposite side of anchor bolt radius. From this point you can work both directions from both anchor bolts.

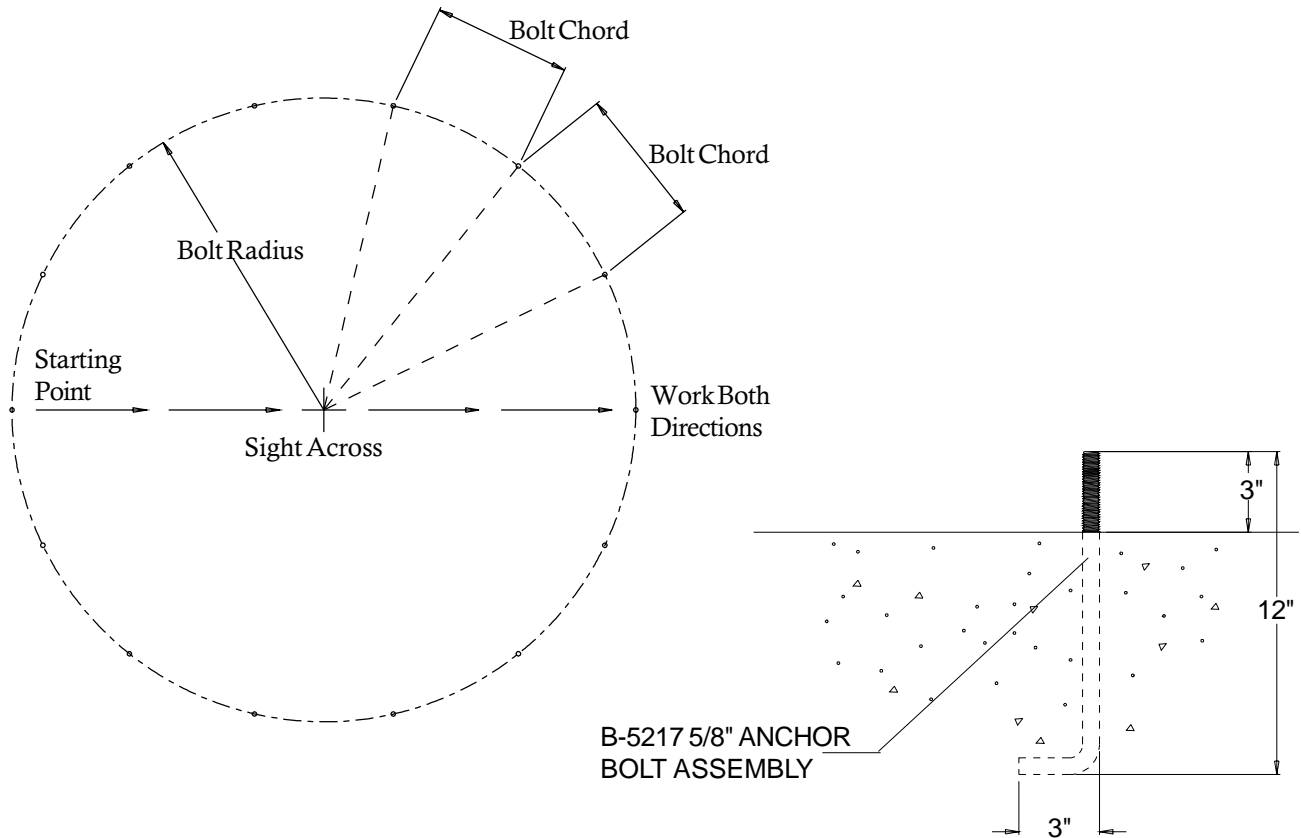
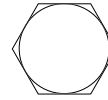

Figure #5
5/8" Anchor Bolt Detail

Bin Diameter	Bolt Circle Radius	Number of Anchors	Bolt Chord Distance
24'	12'-2.5/16"	16	4'-9.3/16"

HARDWARE/BOLTING REQUIREMENTS

NOTE: Grade 2 bolts are designated with a plain head.



NOTE: Grade 5 bolts are designated by 3 slash marks on the head.
All 5/16" diameter bolts are to be Grade 5 or higher.

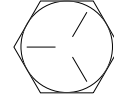

NOTE: Grade 8 bolts are designated by 6 slash marks on the head.

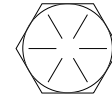

NOTE: Grade 8.2 bolts are designated by 6 slash marks on the head in a sunrise pattern.

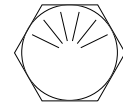

All 3/8" diameter bolts are to be Grade 8 or 8.2.

IMPORTANT: Do not tighten bolts to exceed the torque specifications listed below.

BOLT SIZE	TORQUE (ft. lb.)	
	MINIMUM	MAXIMUM
5/16" - 18	15	20
3/8" - 16	35	42
7/16" - 14	65	72
1/2" - 13	95	105

CAUTION: UNDER NO CONDITION SHALL ANY OTHER BOLTS BE SUBSTITUTED FOR THOSE SUPPLIED BY GRAIN SYSTEMS, INC.

IMPORTANT: HARDWARE USAGE - 20 gauge - 15 gauge sidewall sheets, use 5/16" x 3/4" bolts and nuts. (S-275)

14 gauge and 13 gauge sidewall sheets, use 5/16" X 3/4" bolts and nuts. (S-275)

- Use 5/16" x 1.1/4" (S-277) for attaching floor flashing to the sidewall.



**REFER TO TOP DRY TANK BOLTING REQUIREMENTS
FOR COMPLETE BOLT USAGE**

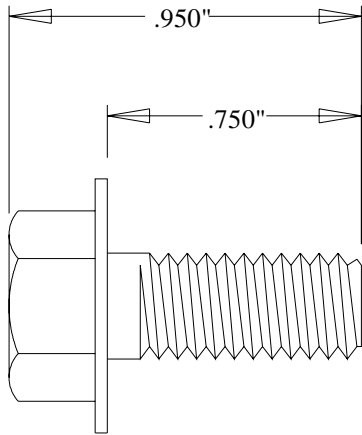

SIDE VIEW

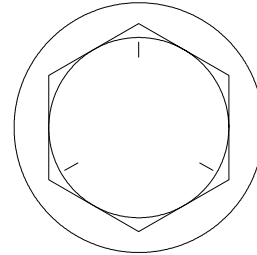

**GRADE 5
TOP VIEW**

S-275

.3125" x .750" pre-assembled with a steel backed neoprene washer.

This bolt is used to connect horizontal and vertical seams for 13 gage and thinner sidewall sheets to each other, and to bolt the stiffeners to the sidewall sheets. It is also used in attaching roof panels to the top sidewall sheet and attaching roof panels and flashing to the center collar.

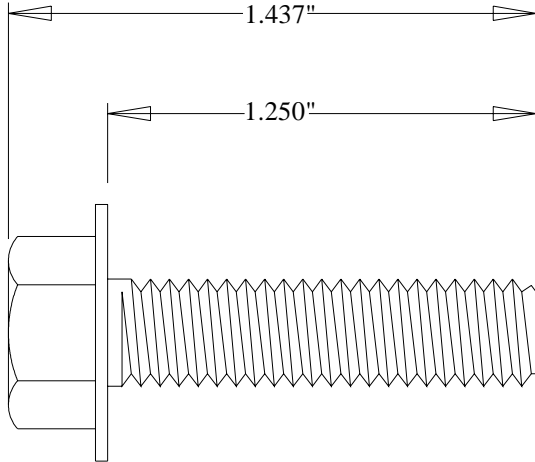

SIDE VIEW

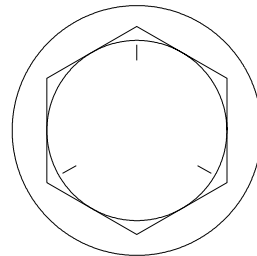

**GRADE 5
TOP VIEW**

S-277

.3125" x 1.250" pre-assembled with a steel backed neoprene washer.

This bolt is primarily used to connect roof panels together where they overlap. It is also used at the bottom of the flat bottomed bins to attach the base angle to the sidewall sheet. A small number of these are provided for joints and FC-42076 splice plates for the stiffeners to sidewall connection.

Figure #6

**REFER TO TOP DRY TANK BOLTING REQUIREMENTS
FOR COMPLETE BOLT USAGE**

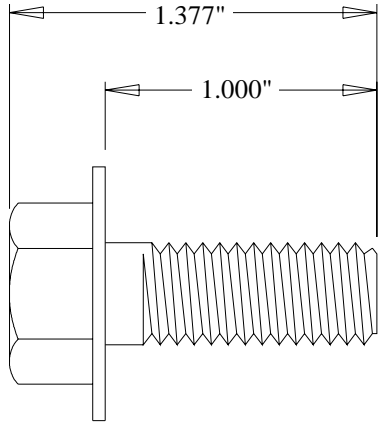

SIDE VIEW

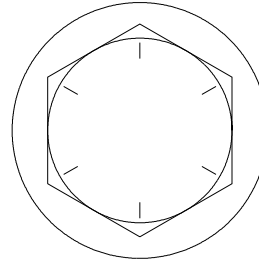

GRADE 8

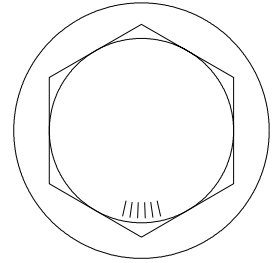

GRADE 8.2

TOP VIEW

S-7927

.375" x 1.000" hex flanged head **without** a plastic sealing washer.

This bolt is used to splice the stiffeners together on the flanges. A steel flat washer is used on the nut side of the connection. They are also used on "c" channel splices and mounting "c" channel to wall bracket.

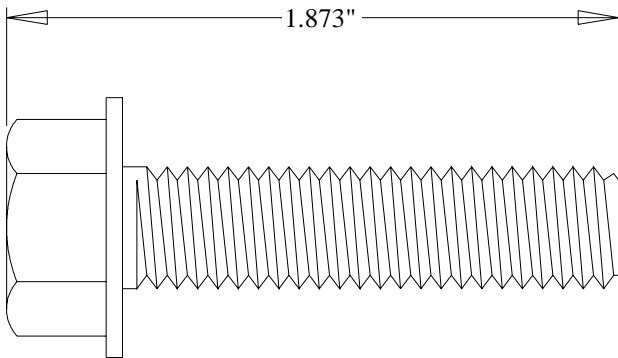

SIDE VIEW

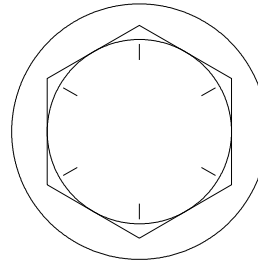

GRADE 8

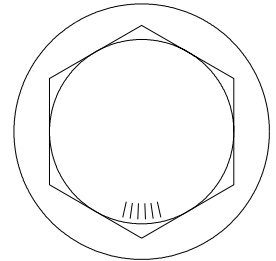

GRADE 8.2

TOP VIEW

S-7928

.375" x 1.500" hex flanged head **without** a plastic sealing washer.

This bolt is used to attach the wall bracket to the sidewall and stiffener. A steel flat washer is used on the nut side of the connection.

Note: The only washers shipped loose with the bins are the steel flat washers. The 5/16" steel flat washer (S-845) is used where the base angle attaches to the sheet and some are used at the main eave clips. The 3/8" steel flat washers (S-248) are used at the stiffener splices and some are used in the roof rafter splices.

Figure #7

LOCATION OF ACCESSORIES

Below is a typical Top Dry bin layout showing suggested locations of Top Dry Accessories. When locating the manway be sure the outside ladder will not interfere with other accessories below. Roof vents should be spaced evenly around the roof. (Quantity will vary with individual systems.)

NOTE: The Top Dry system should be provided with a dependable equipment ground.

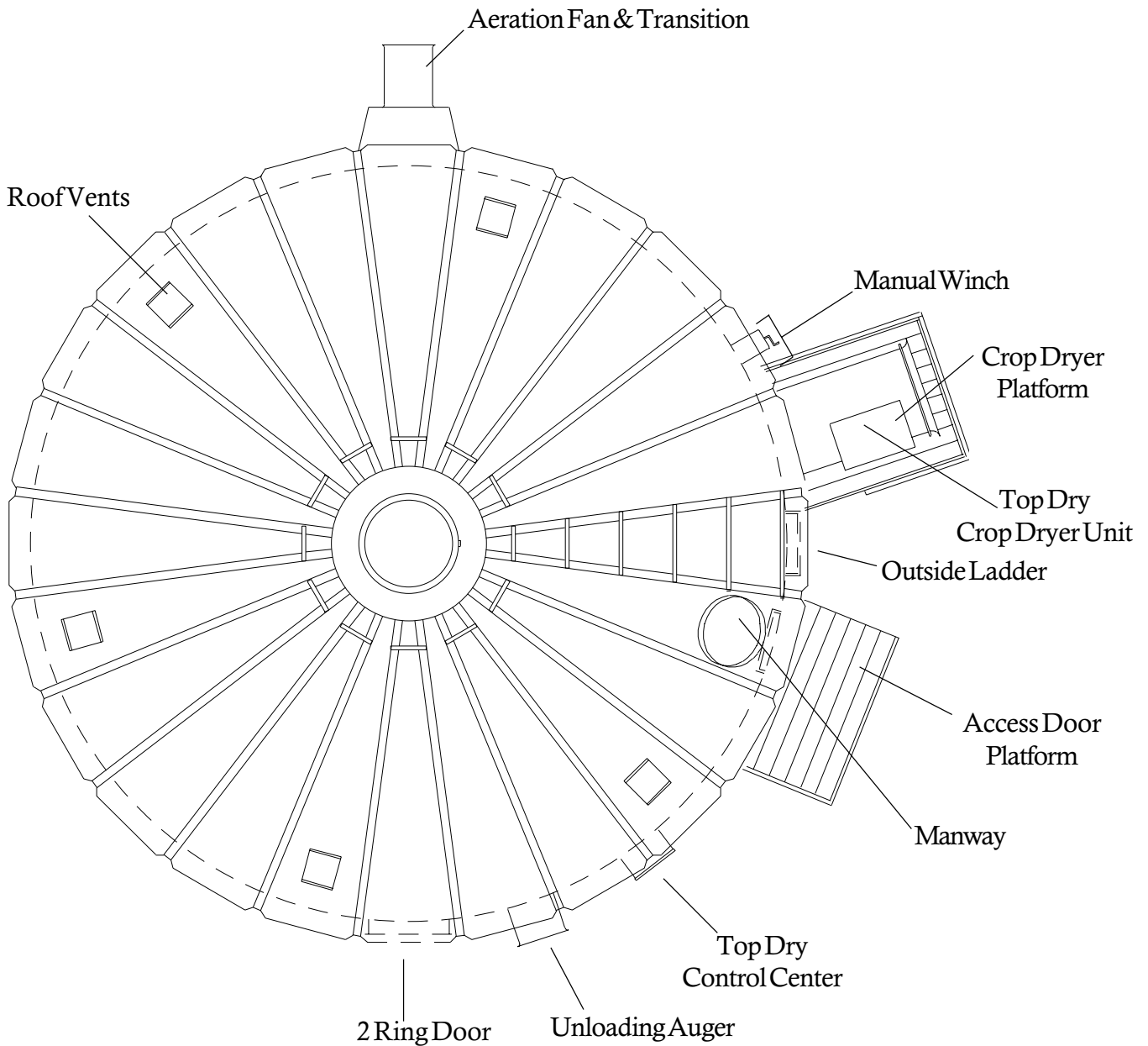
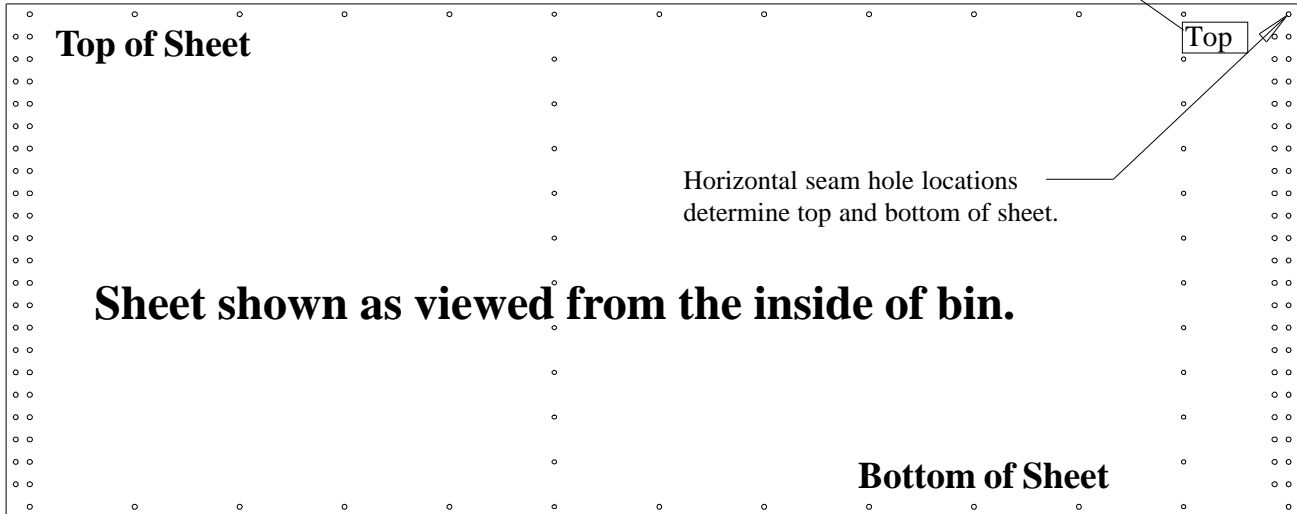

Figure #8



VERY IMPORTANT!

DC-1174 (Top Decal)



All 4.00" corrugated sidewall sheets must be placed correctly.

All 4.00" corrugated sidewall sheets have a top and bottom!

Failure to observe this will not allow the door to fit properly.

Carefully review the erection manual and place sidewall sheets as shown.



SIDEWALL & STIFFENER GAUGES

Door locations are shown by the underlined sidewall gauges. Actual gauge of the access door sheet located just below the Top Dry floor is in parentheses.

Top Dry Bin	Sidewall Gauges
TDMS24-5	<u>20</u> <u>20</u> <u>20</u> 20 20 (16)
TDMS24-6	<u>20</u> <u>20</u> <u>20</u> <u>20</u> 20 20 (16)
TDMS24-7	<u>18</u> <u>20</u> 20 20 <u>20</u> 20 20 (16)
TDMS24-8	<u>18</u> <u>18</u> 20 20 20 <u>20</u> 20 20 (16)
TDMS24-9	<u>17</u> <u>18</u> 18 20 20 20 <u>20</u> 20 20 (16)
TDMS24-10	<u>17</u> <u>17</u> 18 18 18 20 20 <u>20</u> 20 20 (16)

24' Stiffener Layout

Odd Ring				Even Ring	
Gauge	Ring			Ring	Gauge
16	1			1	16
16	2			2	16
16	3			3	14
14	4			4	
	5			5	12
12	6			6	
	7			7	10
10	8			8	
	9			9	8
	10			10	

All Top Dry bin stiffeners are mounted on the outside of the bin. See stiffener instructions for stiffener joint details and stiffener to sidewall attachment.

Figure #9



OUTSIDE STIFFENERS

- The XX in the part numbers at the bottom will identify the Stiffener's gauge.
- Example: FC-4205714 is a 2-Ring Standard Stiffener 14 Gauge.

Stiffener Description	Part No.	Overall Length	Color Code
2-Ring 10 Ga. (Base)	FC-4207210	94 27/32"	White
2-Ring 12 Ga. (Base)	FC-4207212	94 27/32"	Black
2-Ring 14 Ga. (Base)	FC-4207214	94 27/32"	Green
2-Ring 16 Ga. (Base)	FC-4207216	93 13/16"	Blue
2-Ring 8 Ga. (Base)	FC-4207308	88 3/16"	Yellow
2-Ring 8 Ga.	FC-4206308	87 15/16"	Yellow
2-Ring 10 Ga. Trans.	FC-42062	94 19/32"	Purple
2-Ring 12 Ga.	FC-4205712	94 19/32"	Black
2-Ring 14 Ga.	FC-4205714	94 19/32"	Green
2-Ring 16 Ga.	FC-4207516	93 9/16"	Blue
2-Ring 18 Ga.	FC-4207518	93 9/16"	Orange
2-Ring 16 Ga. Top	FC-4206516	85 9/16"	Blue
2-Ring 18 Ga. Top	FC-4206518	85 9/16"	Orange
1-Ring 12 Ga.	FC-4205912	50 19/32"	Black
1-Ring 14 Ga.	FC-4205914	50 19/32"	Green
1-Ring 16 Ga.	FC-4207416	49 9/16"	Blue
1-Ring 18 Ga.	FC-4207418	49 9/16"	Orange
1-Ring Top 16 Ga.	FC-4206616	41 7/16"	Blue
1-Ring Top 18 Ga.	FC-4206618	41 7/16"	Orange
Splice	FC-42076	10 11/16"	---

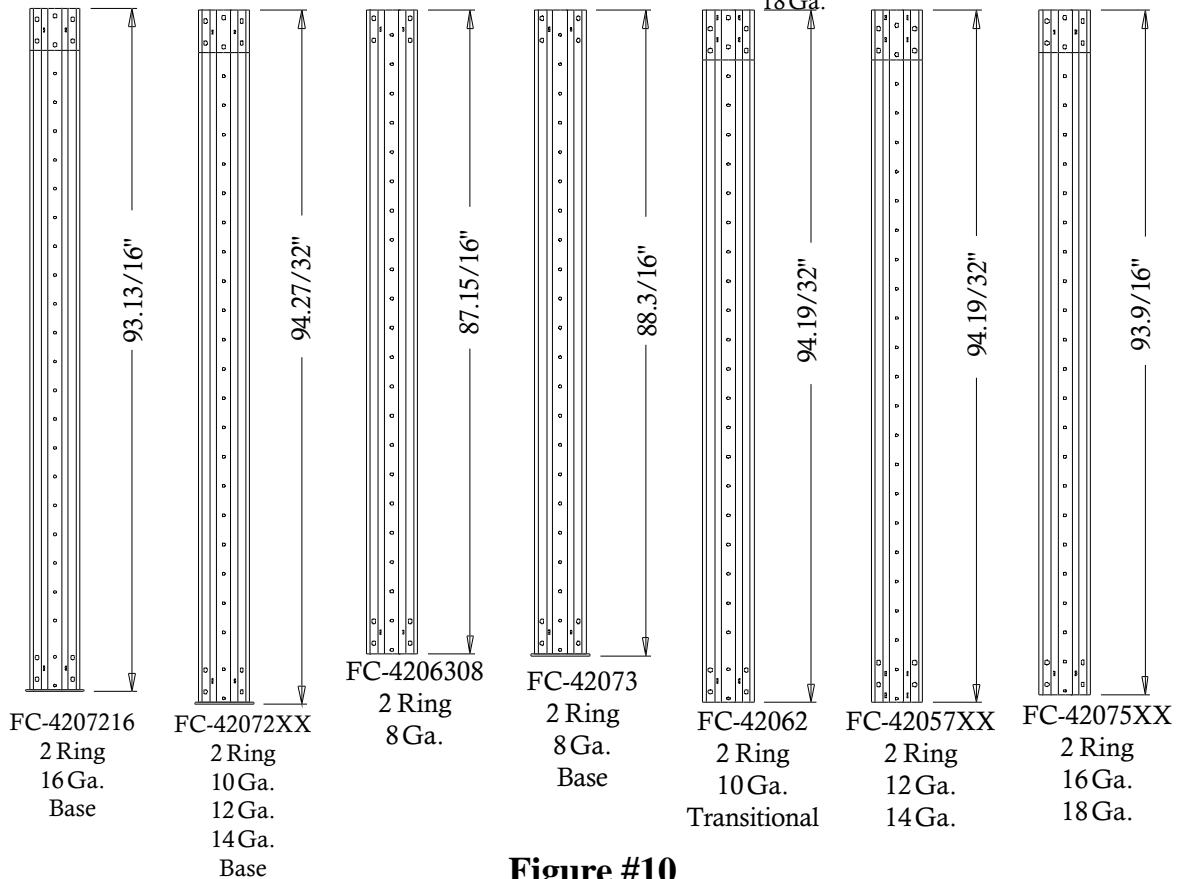
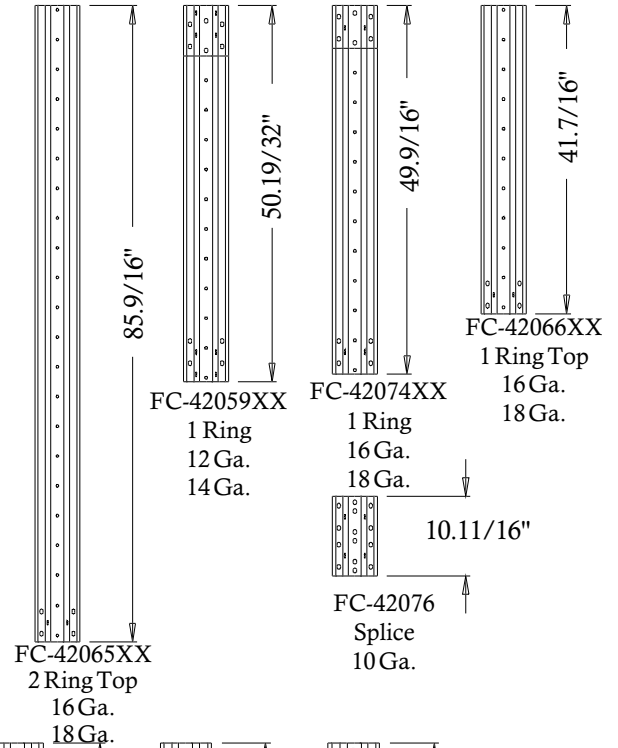

Figure #10

TOP STIFFENER STARTING LOCATION

Refer to Figure #11, for proper location of top stiffeners. On the overlap of the stiffeners, and on the splice, use 3/8" x 1" hex bolts, a washer on the nut side connection. Refer to the stiffener layout, Figure #9, for stiffener usage.

All stiffeners are outside the bin wall. Use 5/16" x 3/4" Grade 5 bin bolts with head and neoprene washer to the inside of the bin wall. Refer to proper charts and illustrations on the previous two pages for proper location of stiffeners and sidewall sheets.

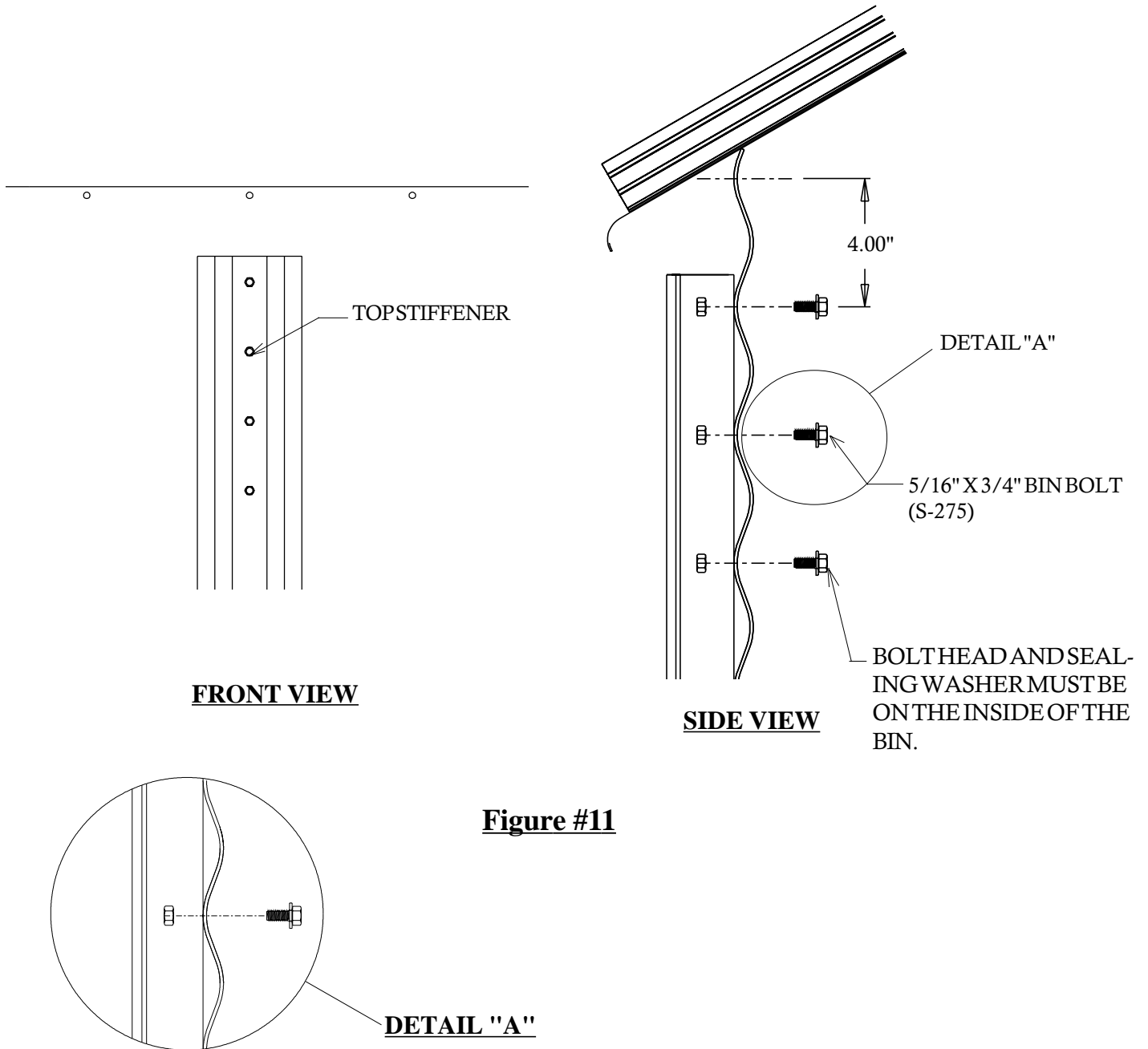

Figure #11

STIFFENER INSTALLATION & LOCATION

When installing bottom stiffeners, you may find that in some cases the stiffener with base plate attached will not rest on the foundation (due to unlevel concrete, etc.) Shim plates have been furnished and should be used to fill opening between base plate and concrete.

IMPORTANT: If shim plates are not used where required, the downward pressure of the stiffeners will not be transferred directly to the foundation, and bin failure could result.

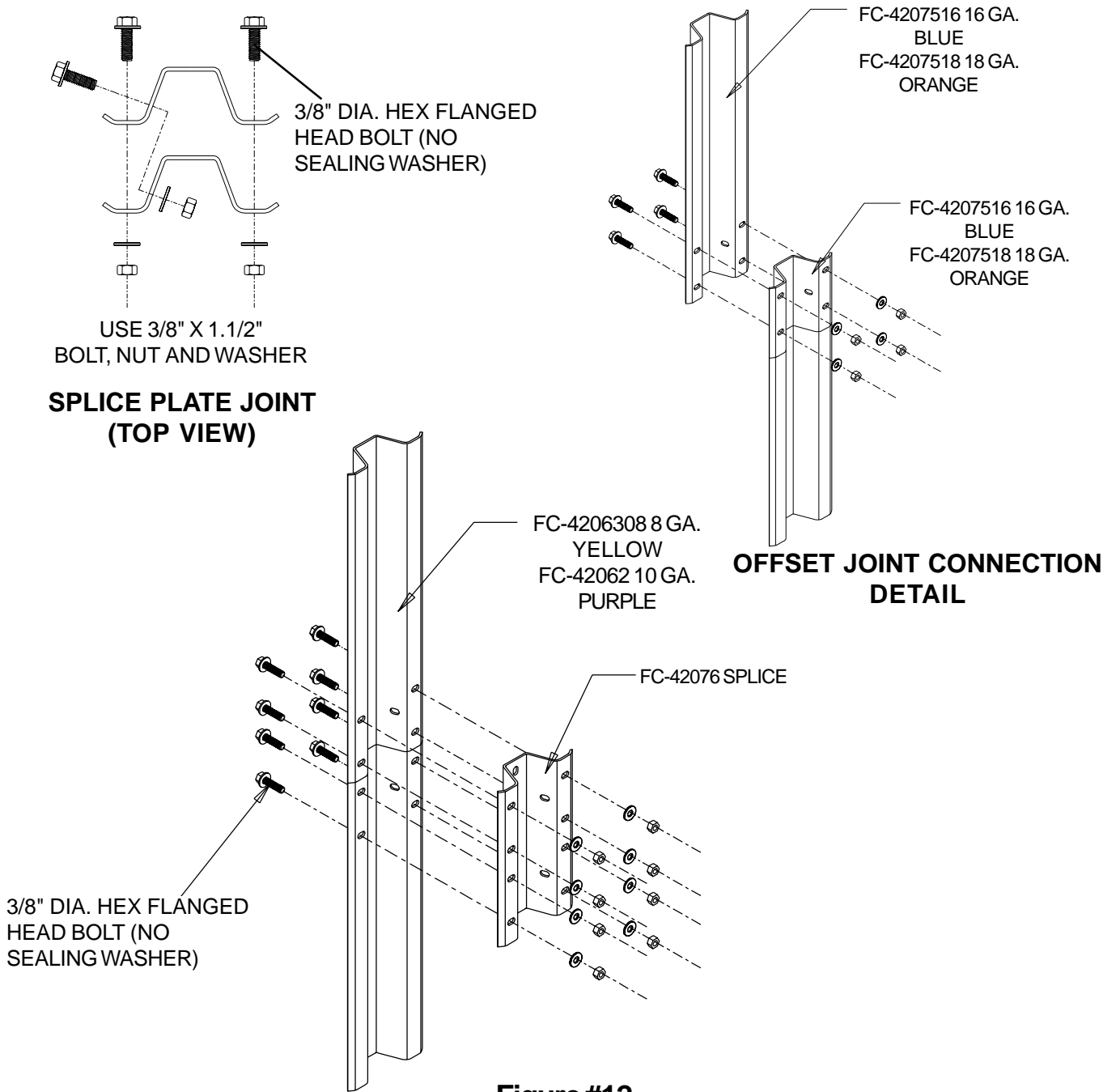

Figure #12



BOLTING REQUIREMENTS

2 STIFFENERS PER SIDEWALL SHEET

Sidewall Gauge	Horizontal Seam	Vertical Seam	Stiffener To Sidewall	Overlap Seam
17 Thru 20	5/16" x 3/4" [10]	5/16" x 3/4" [42]	5/16" x 3/4" [20]	5/16" x 3/4" [2]

All bolts are standard bin bolts with neoprene washers. For horizontal and vertical seam bolts, the bolt head and neoprene washers are on the outside of the bin.

Note: For the splice plates FC-42076 use 5/16" x 1.1/4" bolts for the stiffener to sidewall connections.

Standard (17 Gauge Thru 20 Gauge) Sheet Bolting Detail
(Viewed from outside of the bin)

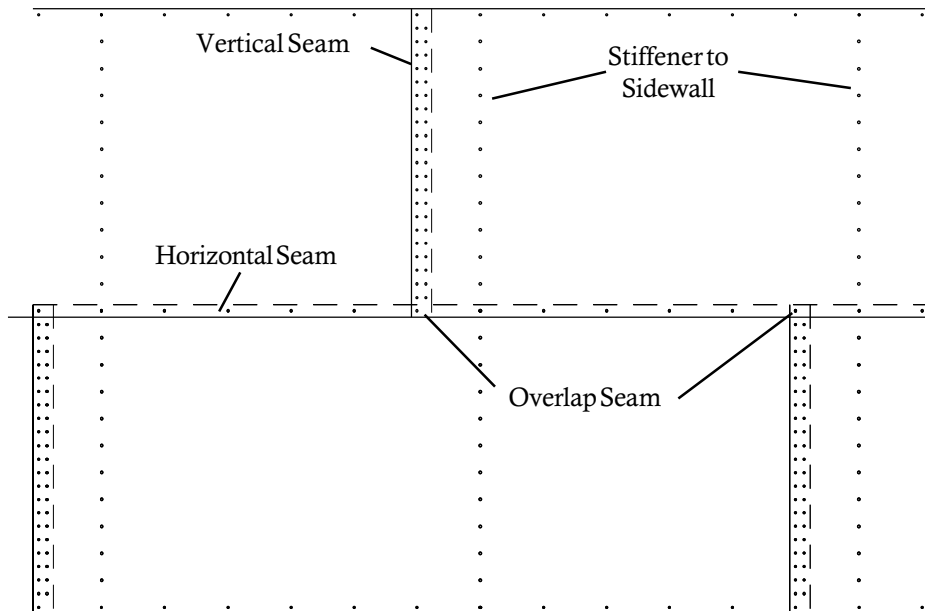
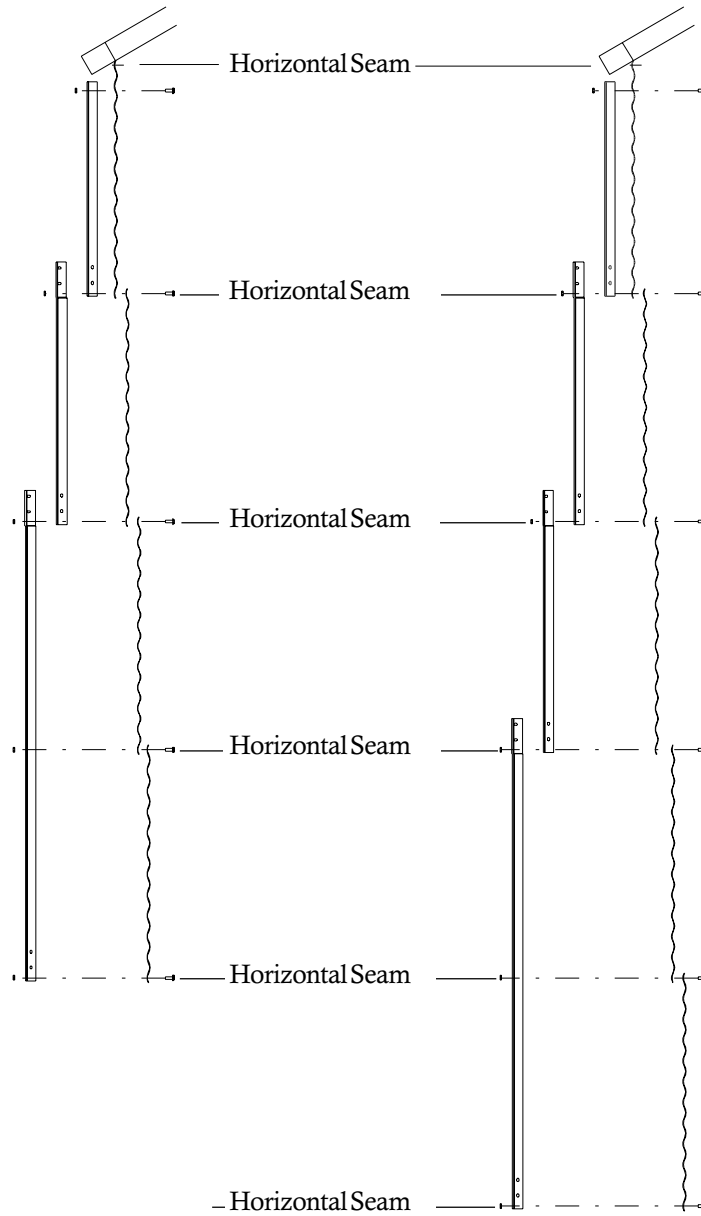

Figure #13

STIFFENER & SEAM LOCATIONS

Even Ring Bins

Odd Ring Bins



2 stiffeners per sidewall sheet
Top Dry stiffener starting location - 18' to 36'
4" corrugation stiffener only

Figure #14

SIDEWALL CONSTRUCTION INSTRUCTIONS

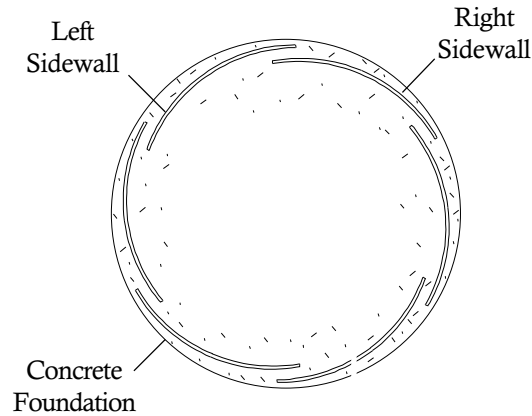

Figure #16

Using correct size bin bolts throughout, begin assembling sidewall sheets end to end (overlapping the same way throughout) until the ring is complete. All body sheet bolts are to be installed with the bolt head and its neoprene washer to the outside and the nut on the inside. Do not tighten bolts until all sheets are assembled and form a complete ring. Tighten the bolts in sequence, starting from the center and work to the edge in both directions. This permits the sidewall sheets to draw-up evenly.

After assembling the second ring, lift the top ring sheets in place, add top stiffeners, build the Top Dry floor, then the roof.

Note: The sidewall sheets used for the top ring are punched to accommodate the eave flashing bolts.

Note: The fan entrance sheet and access door are located in the second ring. Attach the top stiffeners, leaving out the (7) bolts indicated in Figure #15 at each stiffener location. Install the flashing bolts from the outside.

Top Two Rings

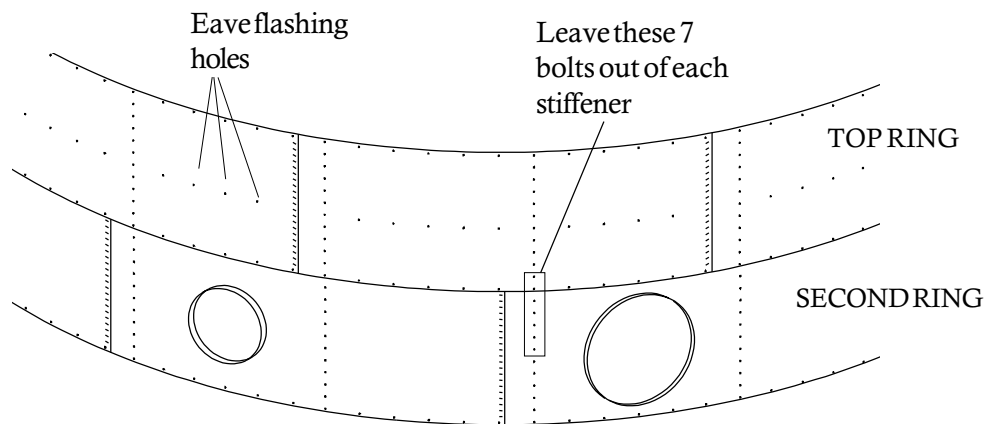

Figure #17



STIFFENER AND BRACKET INSTALLATION

Install the stiffeners on the outside of the bin (as shown in Figure #14) and the wall brackets on the inside of the bin. The wall brackets are to be positioned with the bracket's top hole matching the first hole up from the horizontal seam (not counting the horizontal seam). Bracket to sidewall connection using a 3/8" x 1.1/2" bolt (S-2086), head outside, with a neoprene washer (S-3558) against the wall on the inside, and a corrugation spacer (S-7041). NOTE: It may be necessary to ream out sidewall holes with a drill and 3/8" bit for easier installation.

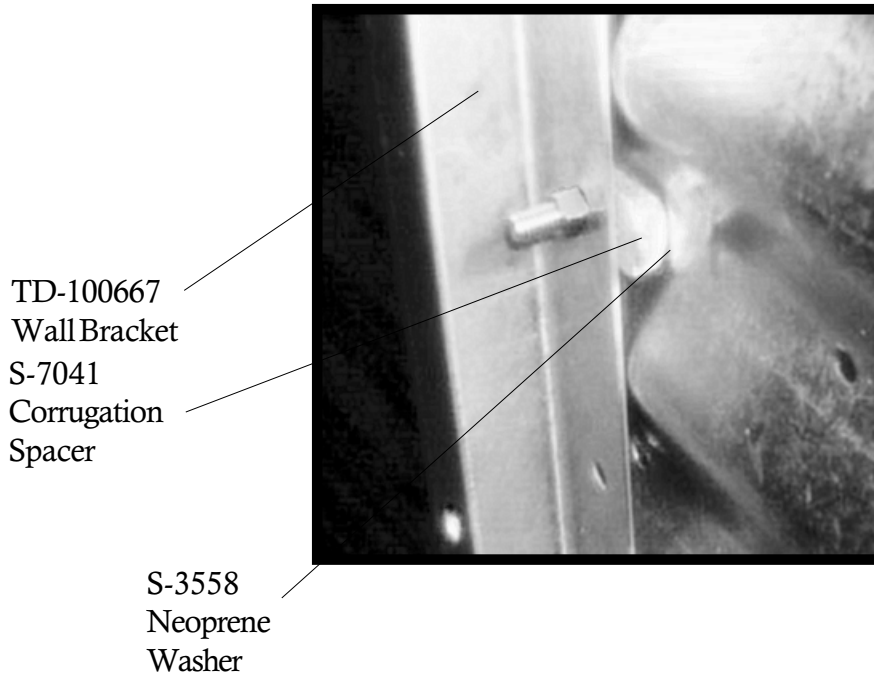

Figure #18

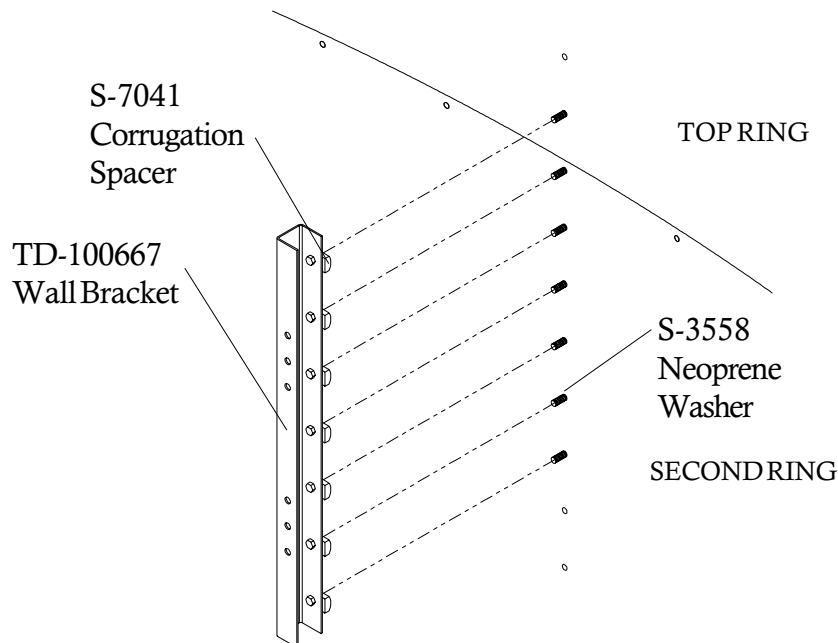

Figure #19

"C" CHANNEL INSTALLATION

Fasten the rolled "C" eave members to the wall brackets in the upper 2 holes of the top set of three (3) holes leaving the bolts loose.

Install the splice plates at the rolled "C" eave member seams using 3/8" x 1" flanged hex bolts and nuts. Install bolts as shown below. Tighten all bolts.

"C" Channel Attachment.

TD-100763
Eave "C" Channel

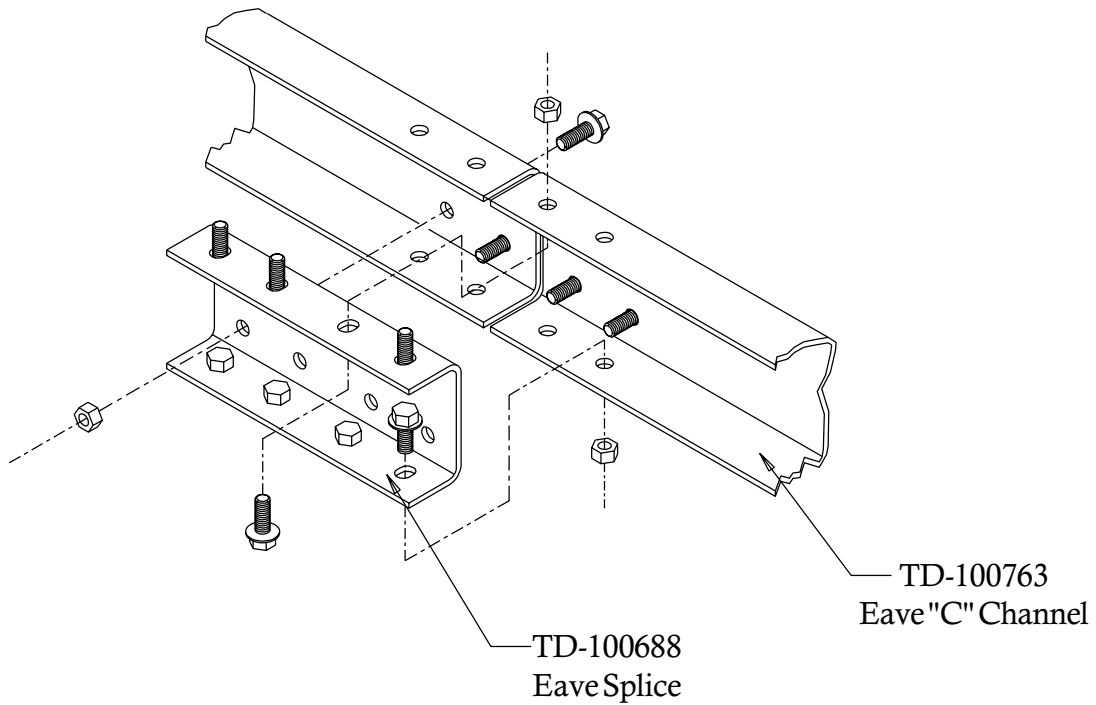
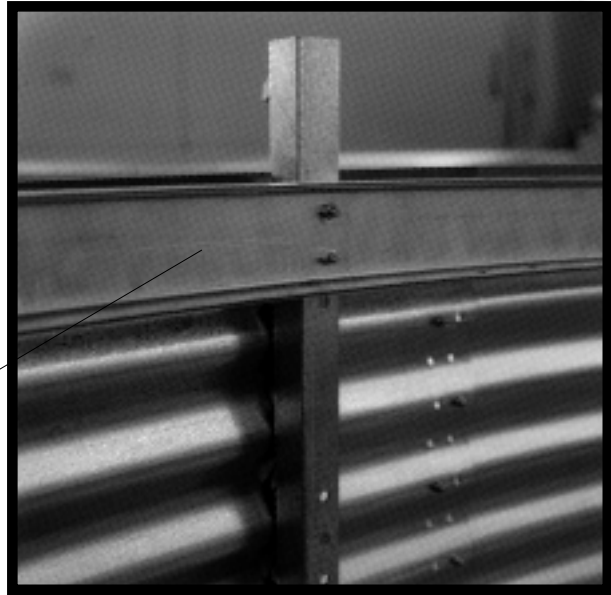

Figure #20

CENTER COLLAR ASSEMBLY

Add channel braces and brace plates to center collar as shown using 3/8" x 1" bolts and nuts. (Do not attach cross channel until floor is done.)

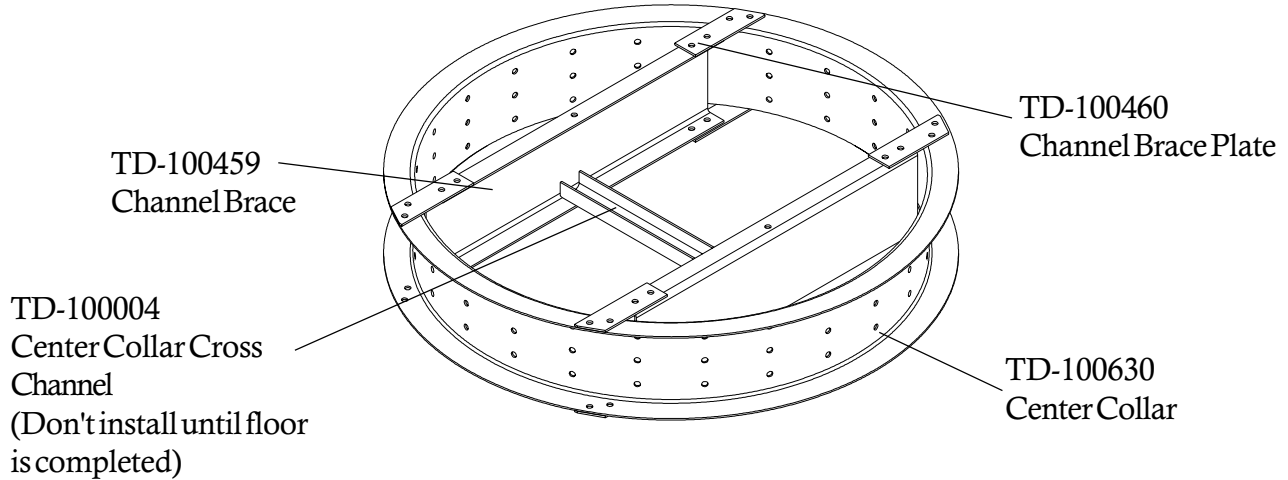

Figure #21

Position the center collar at the center of the bin and raise it to approximately 8'-9.1/2" measuring from the bottom edge of the collar to the concrete.

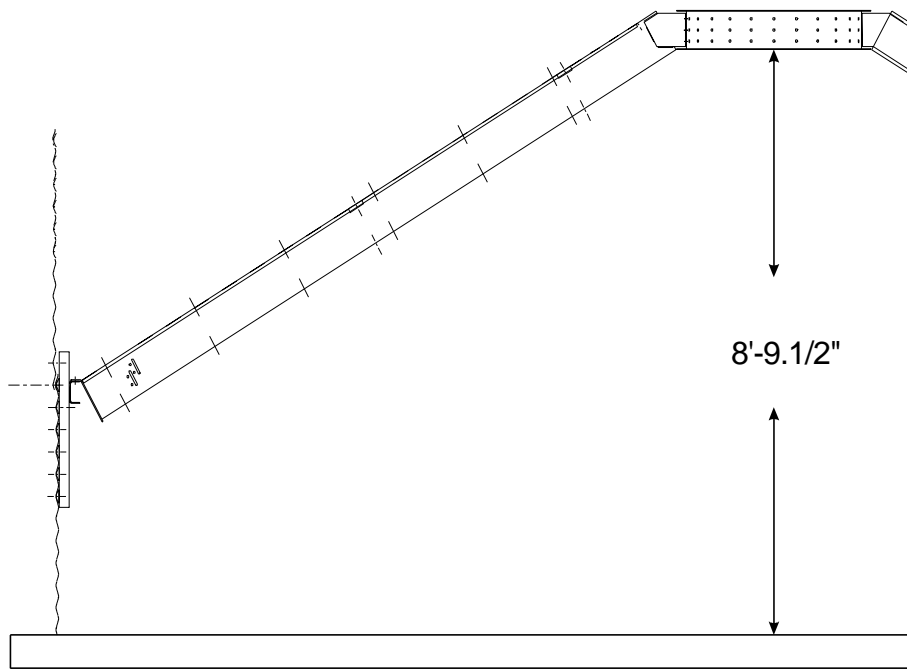
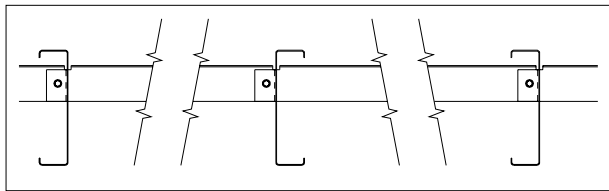

Figure #22

RAFTER INSTALLATION & FLOOR SUPPORT ANGLE ATTACHMENT

When installing the rafters, set the lower clip end on the "C" eave member. Leave the bolts to the center collar and the eave member loose until all rafters are in place. Use 3/8" x 1" hex bolts and nuts to connect the center collar and eave member to three (3) rafters at 90 degrees to each other. These first three (3) rafters should all face the same direction. Every other rafter should alternate direction. **IMPORTANT:** There are left & right rafters. Be sure to alternate left, right, left, right, etc.. The floor sheet support purlins can now be installed using 5/16" x 3/4" bin bolts. There are two (2) different lengths of purlins to fit between the rafters. Insert the straight tab of the purlin through the upper slot in the left hand rafter when looking toward the bottom of the rafters. Bolt the bent end of the purlin to the right hand rafter in the upper two (2) holes. After inserting the next purlin tab, bolt the first purlin tab to the second purlin. Continue around the bin alternating lengths as the rafter facings did. Tighten all bolts.



Looking toward the sidewall

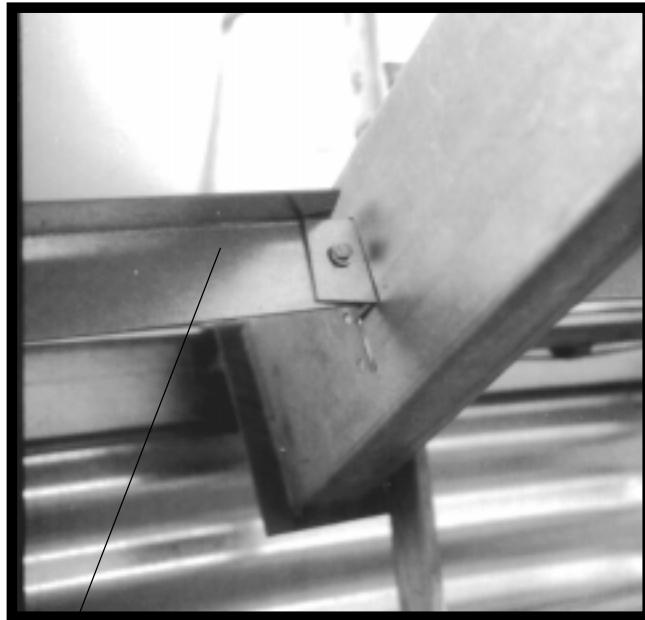

Floor Support Angle Assembly
 TD-100768 Long
 TD-100769 Short

Figure #23

Counting up from the lower end of the rafter, on the underneath side, the angle purlins bolt in the 3rd hole using 5/16" x 3/4" bin bolts. The angle is to be bolted to the underneath side of the rafters, joining rafter to rafter, with the angle interior angle facing the center of the bin. (as shown in the photo). Tighten all bolts.

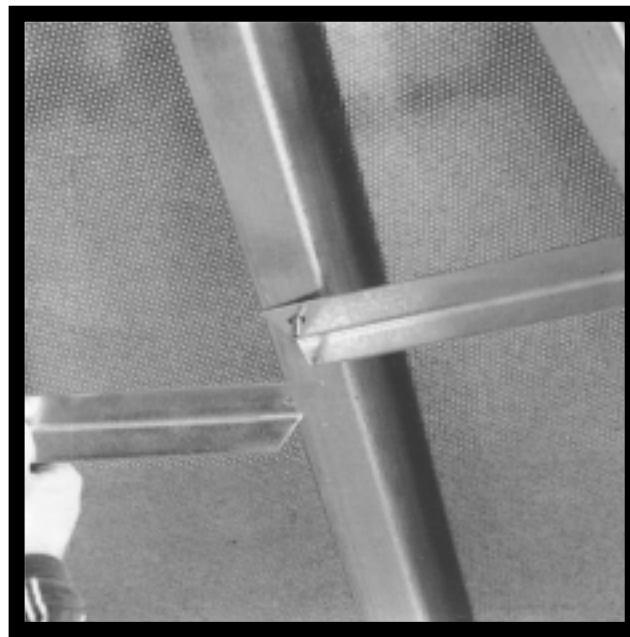
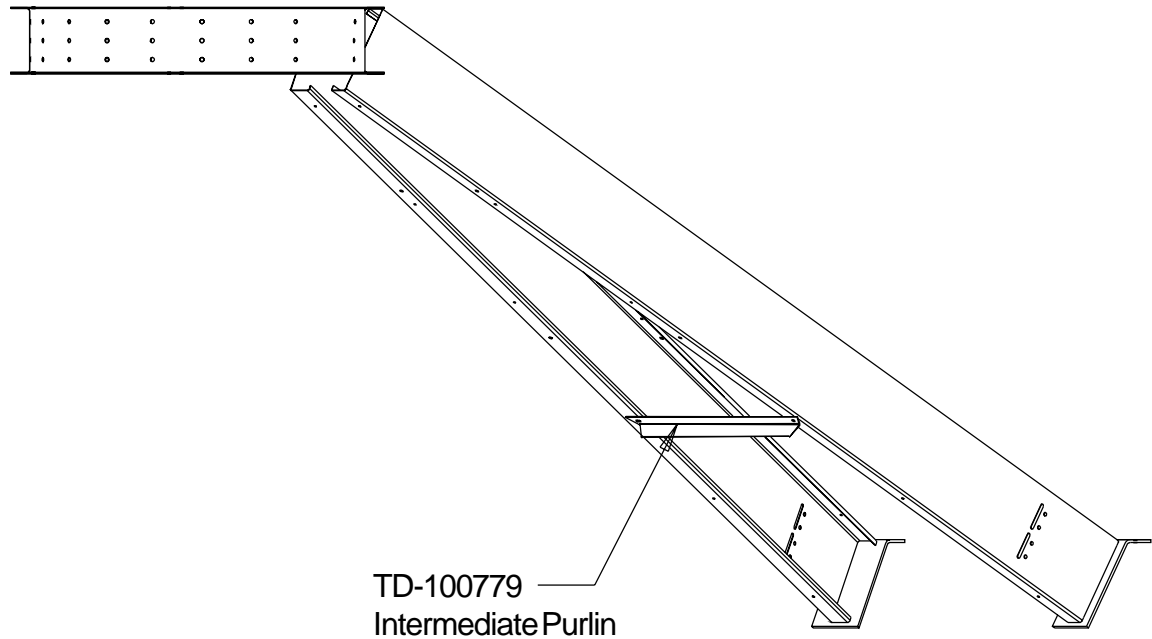

The angle is to be bolted on the underneath side of the rafters, joining rafter to rafter, with the angles interior angle facing the center of the bin.

Figure #24



42" FAN DIFFUSER INSTRUCTIONS & INSTALLATION

Bolt the long side of the hangers to the endmost slots of the top plate (TD-100665) as shown below.

Hold the top plate up under the bottom flange of the "C" channel in front of the fan opening. Mark and drill four 3/8" holes into bottom flange using diffuser hangers as a guide. Using 5/16" x 3/8" bolts and nuts bolt the top plate to the "C" channel.

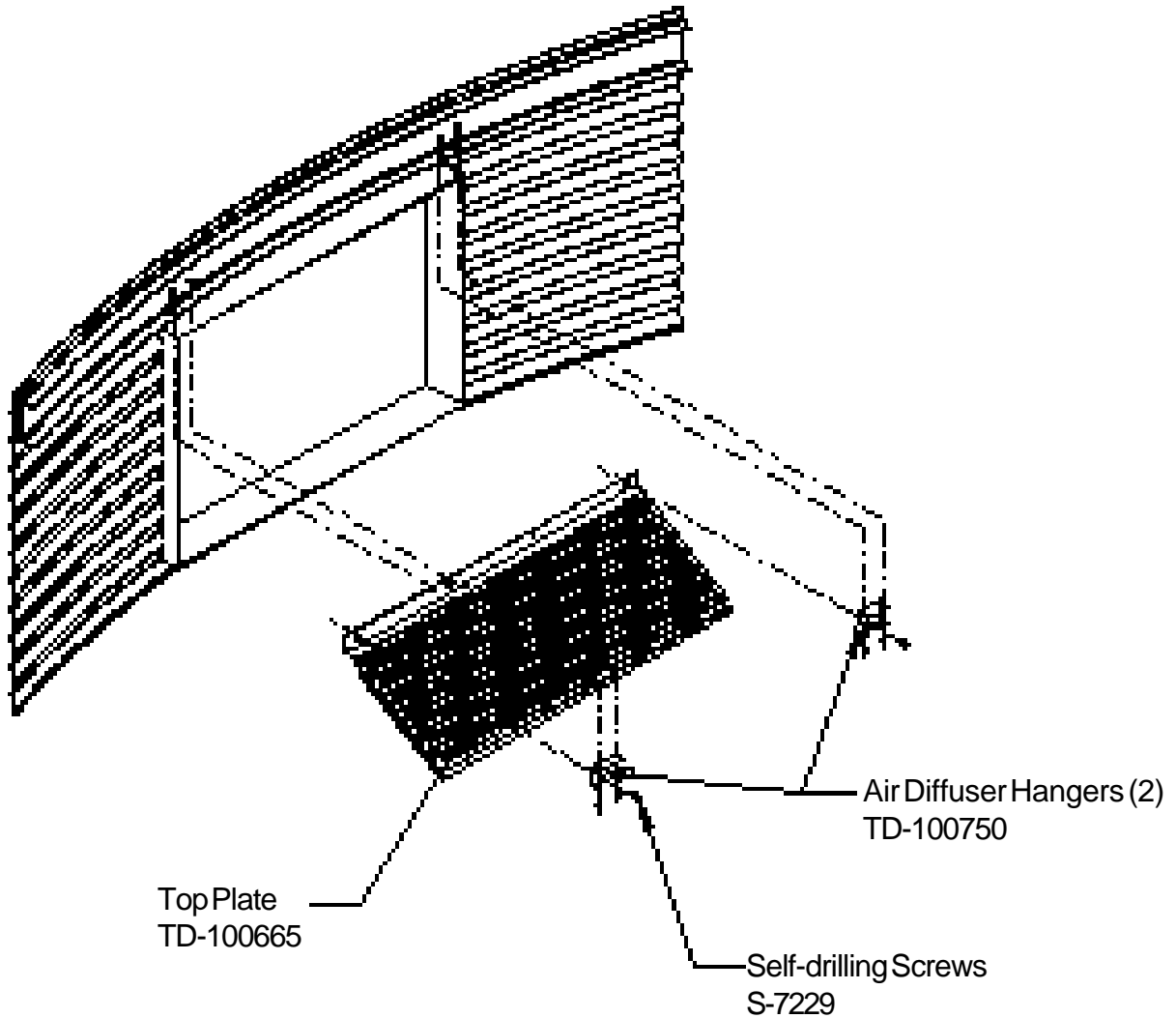

Figure #25

42" FAN DIFFUSER (CONT.)

Attach front plate to the top plate with four (4) 1/4" x 1" self-drilling screws.

Bolt the side brackets to the front plate slot with the angle outward. field drill two (2) holes (on inside corrugation hills) through the sidewall and install 5/16" x 3/4" bin bolts and nuts.

Position the side plates on each side with the angle outward and fasten in place using six (6) 1/4" x 1" self-drilling screws.

NOTE: The corner bolt will need to be removed through the side plate, side bracket and front plate.

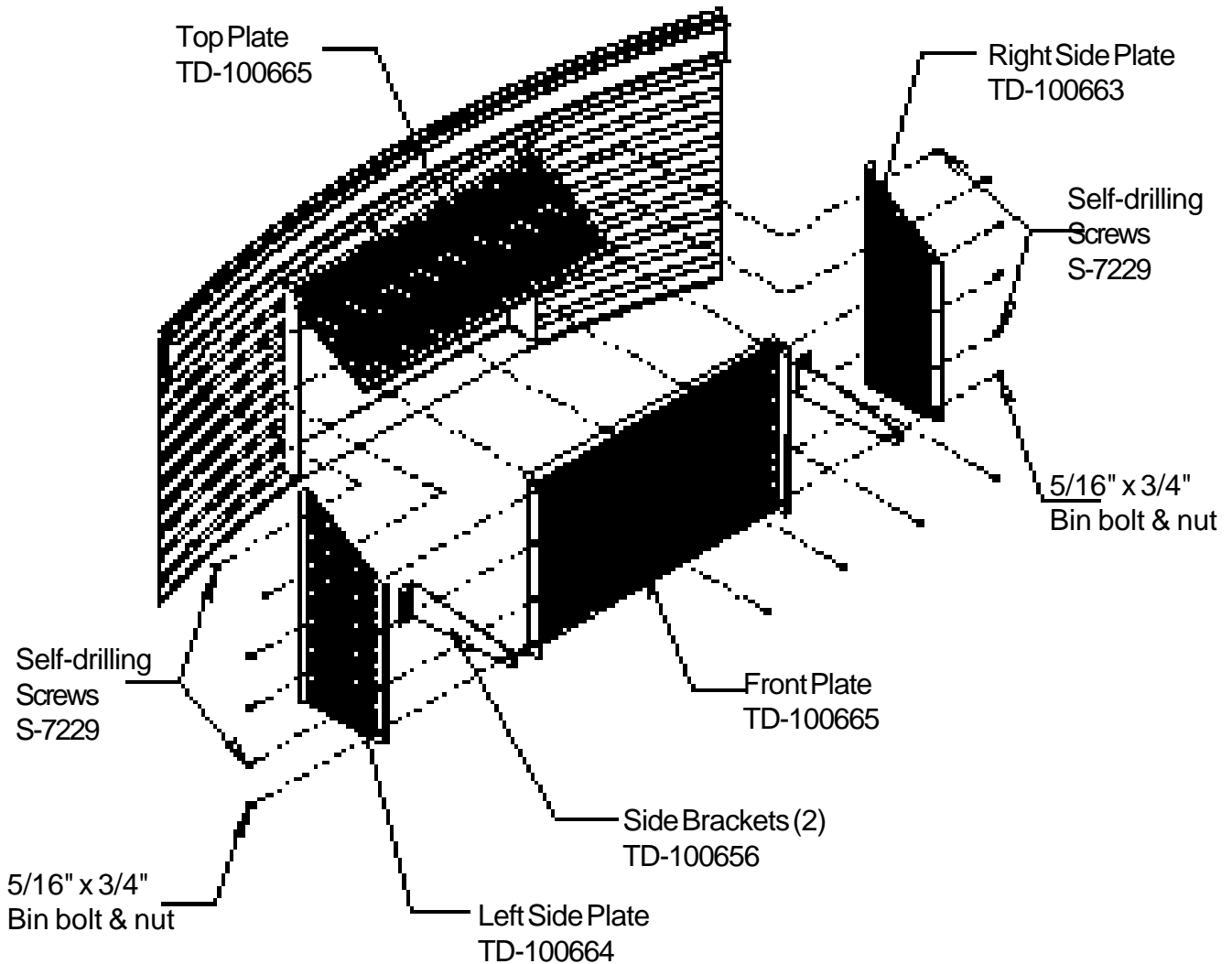

Figure #26

DUMP HOPPER INSTALLATION

Pre-assemble the dump hoppers, dump brackets, and flashing angles to the floor sheets. Place a dump hopper under the floor sheet and align it with the pre-punched large hole. Place a flashing angle on top of the sheet across the outer edge of the hopper entrance with the interior of the angle facing the sidewall. Screw down through the angle, sheet, and hopper with 5/16" x 3/4" self-tapping screws.

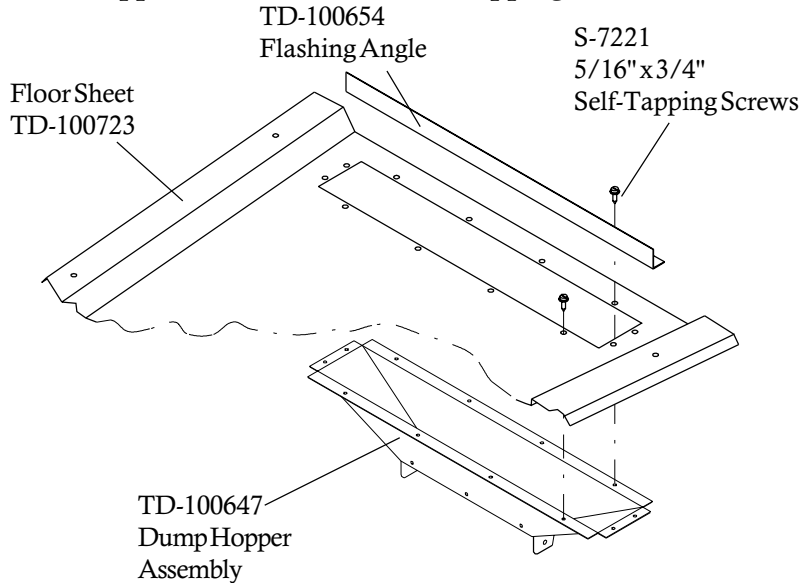

Figure #27

FLOOR SHEET INSTALLATION

Now the assembled sheets can be placed over the rafter framework. As the sheets are placed and overlapped they are to be screwed down to the rafters using 5/16" x 3/4" self-tapping screws, leaving the third and eighth holes empty.

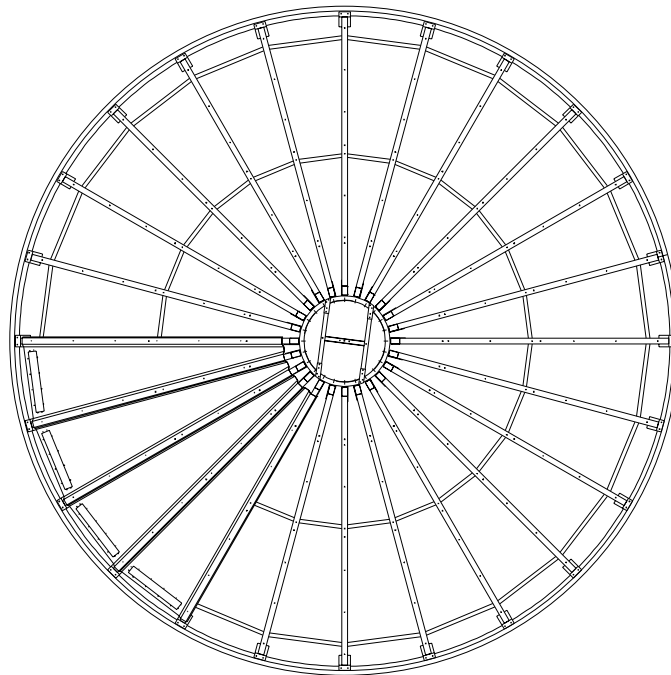

Figure #28

LEVELING BAND POST INSTALLATION

Finish assembling the center collar by adding the cross channels (TD-100004), pulley assembly, cable and lift plate.

Install the leveling band posts on the floor as shown.

The third and eighth holes in the floor sheet indicate the location of the leveling band posts. Attach posts with 5/16" x 1.1/4" bin bolts (S-277). The third hole from the bottom of the sheet, there will be 7 posts (1 every third sheet, except the last bay will cover five sheets). In the eighth hole there will be 5 posts (1 every fourth sheet). After all of the posts have been installed fill the unused holes with 5/16" x 1.1/4" bin bolts.

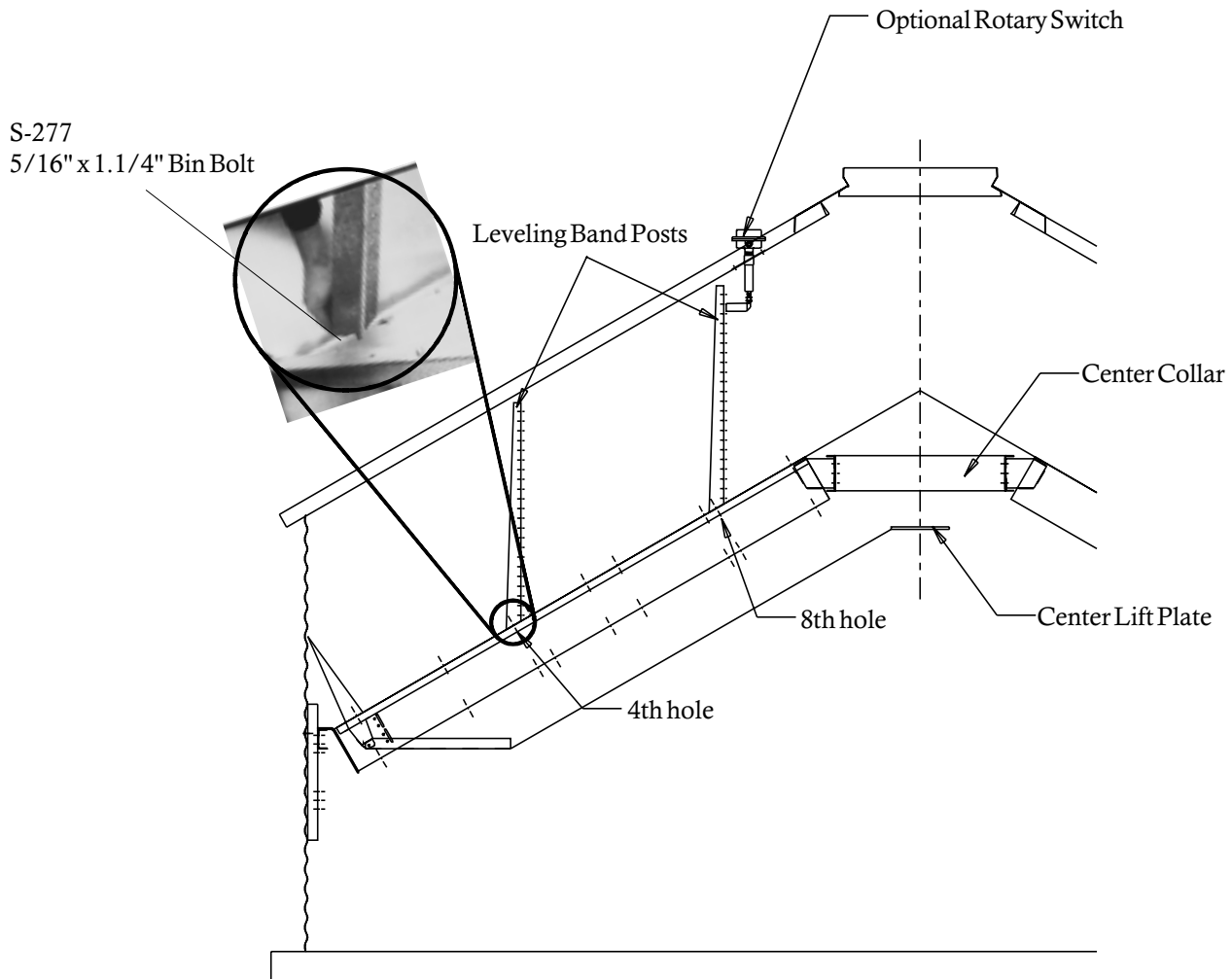

Figure #29

FLASHING BOLT INSTALLATION

Install the eave flashing bolts (5/16" x 1.1/4") through the sidewall and tighten first nut. Note at the vertical sidewall seams, one bolt is turned around to avoid interference with eave flashing (refer to photo).

Left bolt on the each vertical sidewall seam level with the eave flashing bolts (as viewed from inside the bin) is to be installed bolt in, nut out, as shown in the photo to the right.

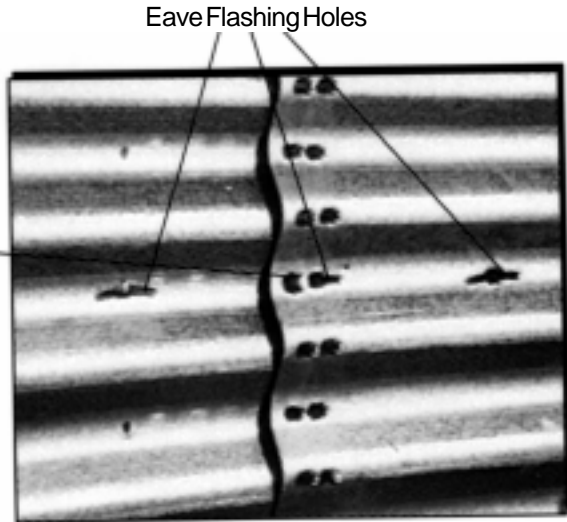
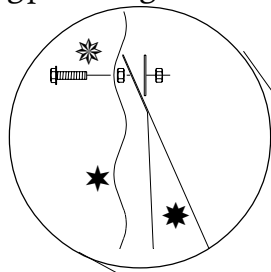

Figure #30

EAVE FLASHING INSTALLATION

Install the eave flashing centered on the floor sheet (1 per) with the bent edge towards the sidewall install a fender washer (S-3671) and nut. Screw the flashing to the flashing angle at the dump hopper opening and screw the flashing pieces together where they overlap with #10 self drilling (S-280) screws.



#10 Self-Drilling
Screws (S-280)

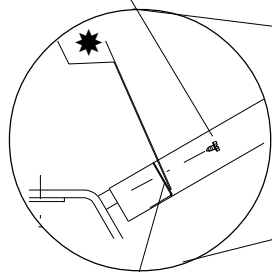

Floor Flashing Angle
(TD-100654)

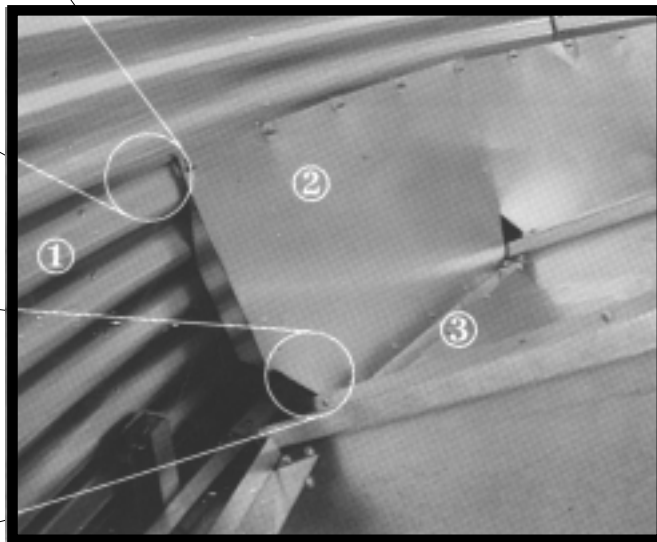

Figure #31 Flashing Attachment. 1) Sidewall, 2) Flashing TD-100648, 3) Floor sheet, 4) 5/16" x 1.1/4" bin bolt. Note that there is a nut in between the sidewall sheet and the flashing sheet.

DISCHARGE PLATE INSTALLATION

Install the discharge plate assemblies over the flashing with a fender washer and nuts letting the bottom bracket rest against the flashing. Screw the discharge plate together where they overlap with #10 self-drilling screws (S-280).

5/16" x 1.1/4" Bin
Bolts with nuts

FenderWasher
(S-3671)

TD-100648
EaveFlashing

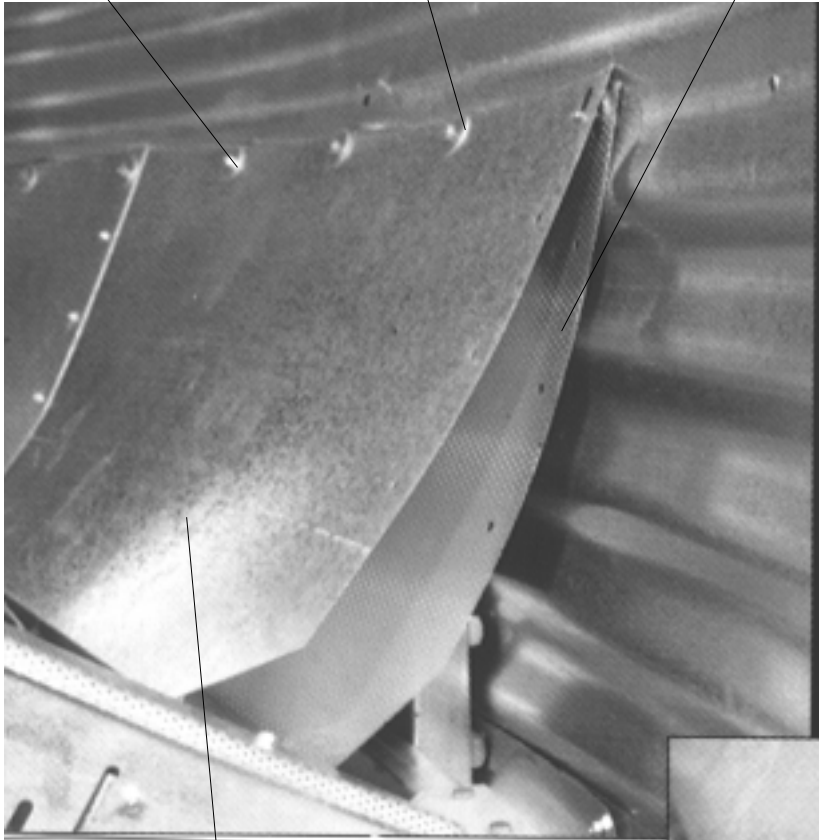

TAF-6112
Discharge Plate

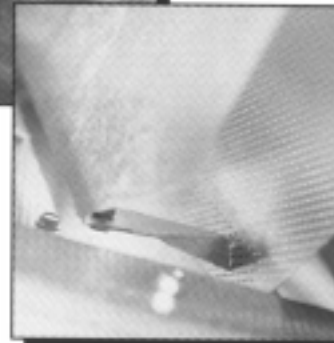

TD-100588
Bottom Bracket for
Discharge Plate

Figure #32

FLASHING SPLICE INSTALLATION

The flashing splice pieces can now be attached to the eave flashing to seal around the rib of the floor sheet as shown with (S-280) #10 self-drilling screws.

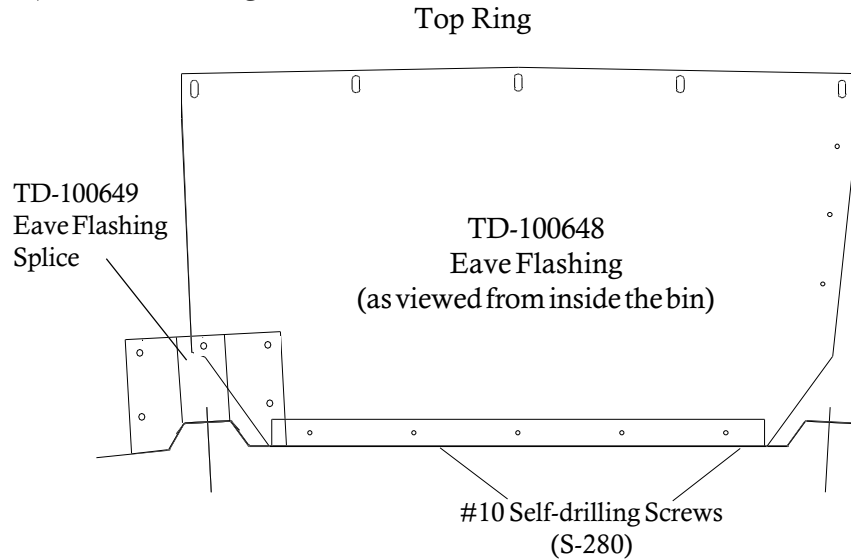

Figure #33

OUTER DUMP CHUTES

Bolt a TD-100598 angle dam to each dump chute using (3) 1/4" x 5/8" bolts and nuts, as shown below. Use 1/4" x 5/8" bolts and double nuts to fasten dump chutes to hopper. Do not tighten first nut down. Lock second nut to first nut and make sure chutes raise and lower freely.

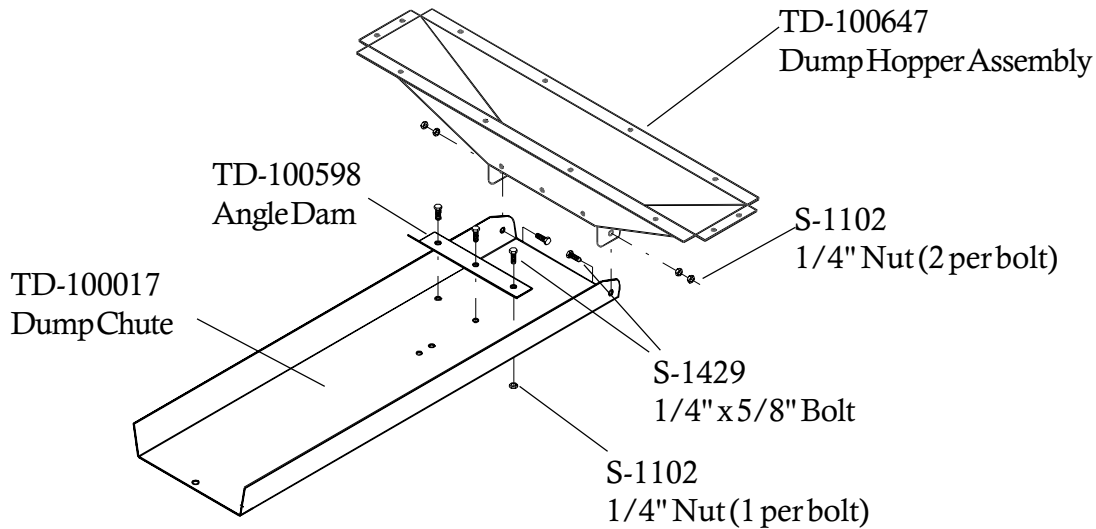

Figure #34

PULLEY ASSEMBLY

Position the pulley assembly to the cross angle in the middle of the center collar assembly. Use a 3/8" x 1" hex head cap bolt to fasten assembly to the cross angle. Position the pulley in the direction of the desired winch location on the sidewall.

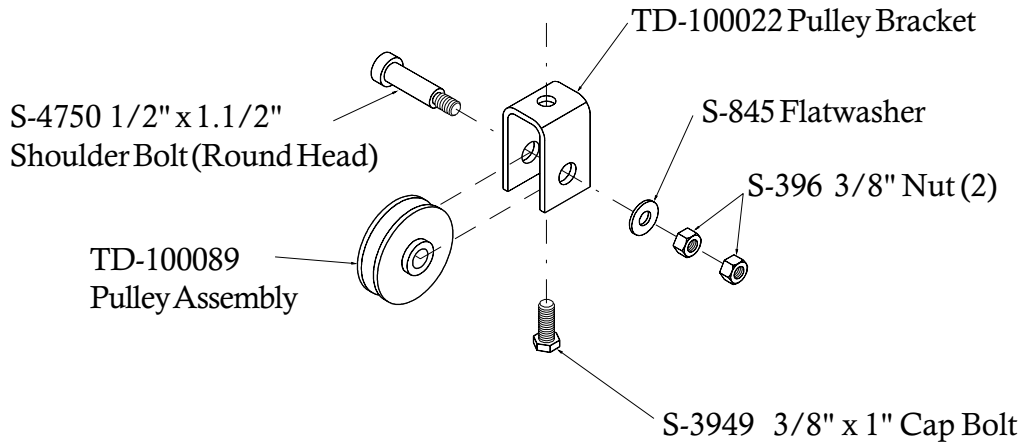

Figure #35

Field drill (5) 3/8" diameter holes as shown at left. Attach the pulley assembly with 5/16" x 3/4" bolts with the neoprene on the inside of the bin.

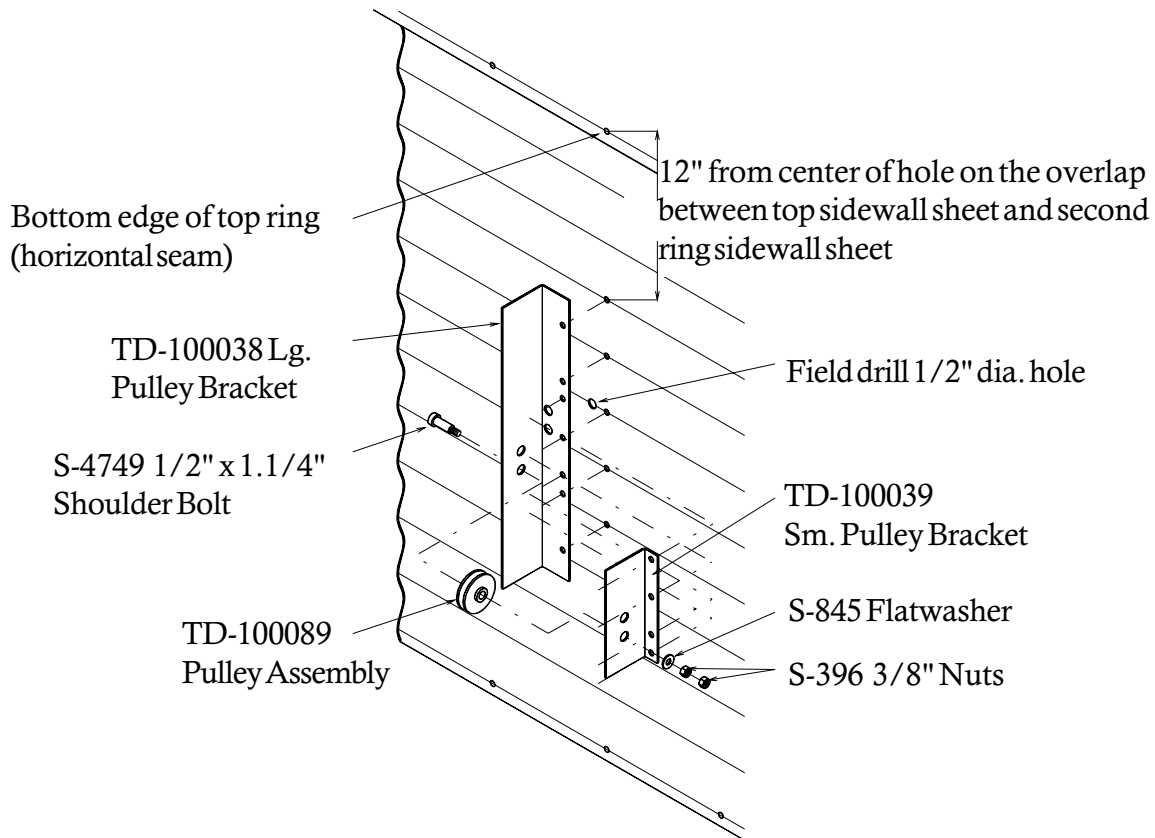
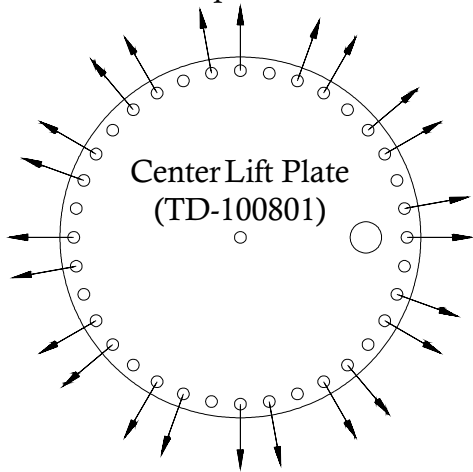

Figure #36

DUMP CHUTE CHAIN ASSEMBLY

Attach all 24 dump chute chains directly to the lift plate as shown in diagram below.

Install all chains using "S" hooks (S-4692) to attach the chains to the dump chutes and lift plates. Keep excess chain at the lift plate. Adjust the chains until the chutes are approximately level when the lift plate is in the closed (up) position. Once the chains are uniformly adjusted, crimp the "S" hooks closed. Check when attaching the "S" hook to the end link on a chain that the end has not been cut open. If this is found remove the end link or shift up and use the next link in chain.



Chain leading to outer chutes (120")

Chutes in closed position

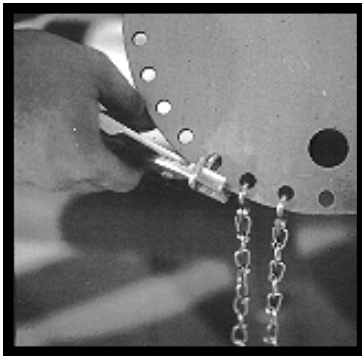

Crimp "S" hooks after final chute adjustment

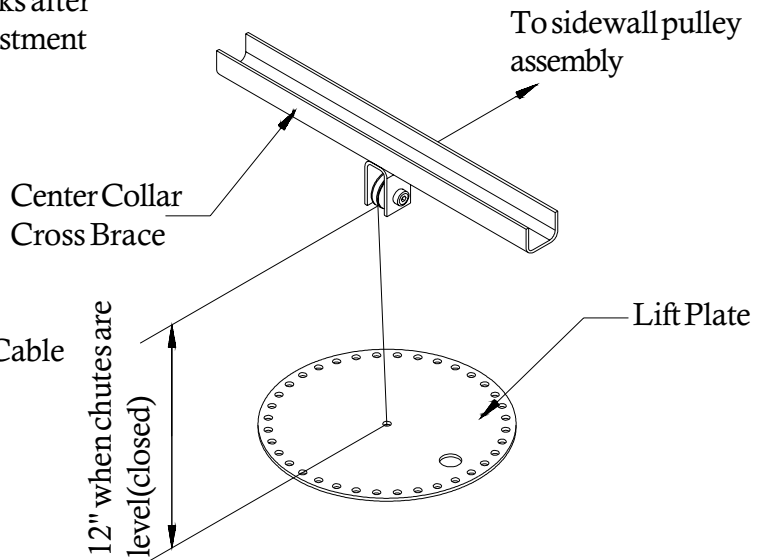
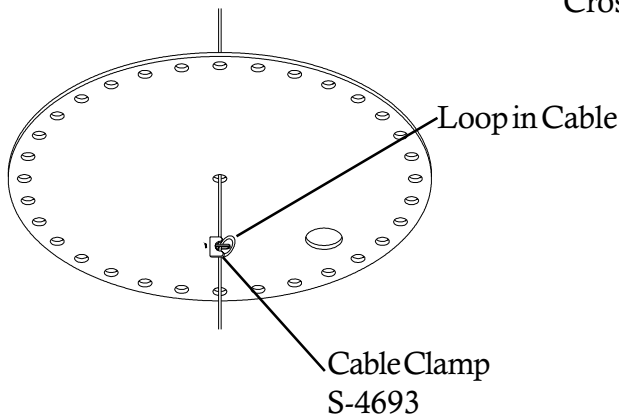
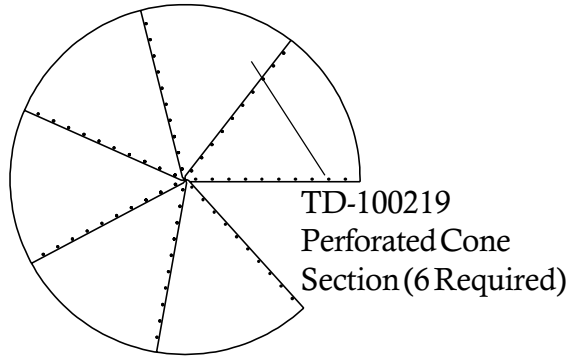

Figure #37

CENTER CONE ASSEMBLY

Bolt the sections together to form perforated cone as shown below. Use 1/4" x 5/8" bolts and nuts to attach sections together.

Flat Overhead View



Formed Overhead View

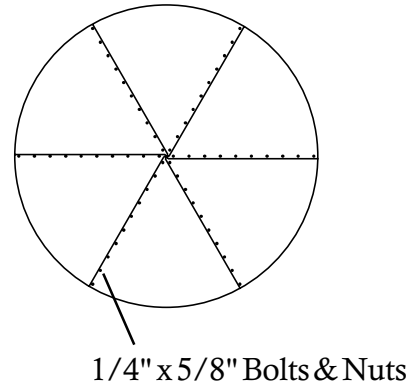

Side Formed View

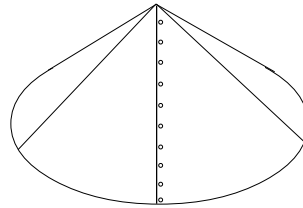

CENTER CONE INSTALLATION

After chains have been adjusted, install cone over the center collar. Fasten Cone Assembly with (12) #10 x 3/4" self-drilling screws (S-280).

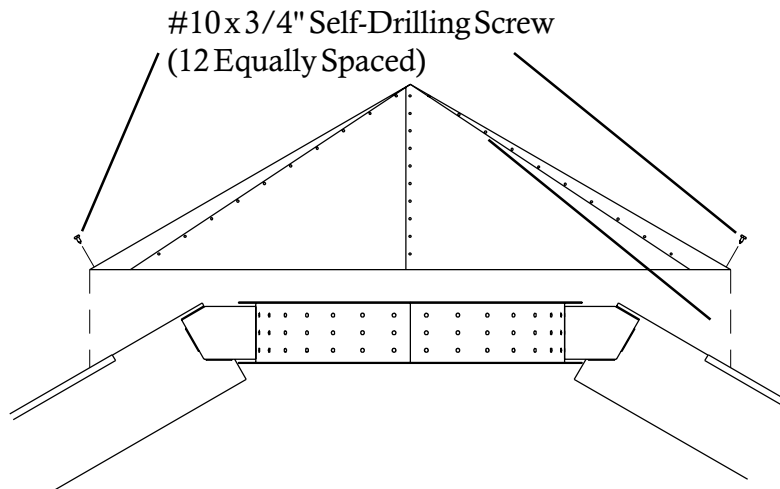

Figure #38



LEVELING BAND LOCATION

Position leveling bands as shown in the drawings below.

Use (2) 5/16" x 3/4" bin bolts to attach bands to posts. Also use 5/16" x 3/4" bin bolts to join band sections. Note that band sections connect to each other only at endmost holes until completing the circle where an overlap may occur.

Inner Leveling Bands

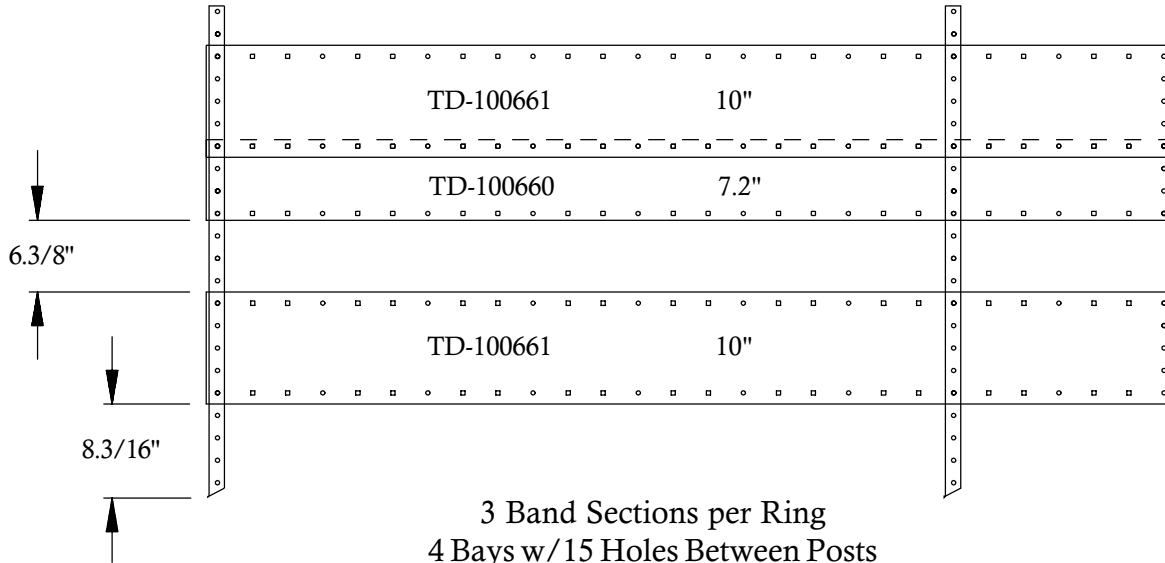

3 Band Sections per Ring
4 Bays w/ 15 Holes Between Posts
and 1 Bay w/ 19 Holes Between Posts

Outer Leveling Bands

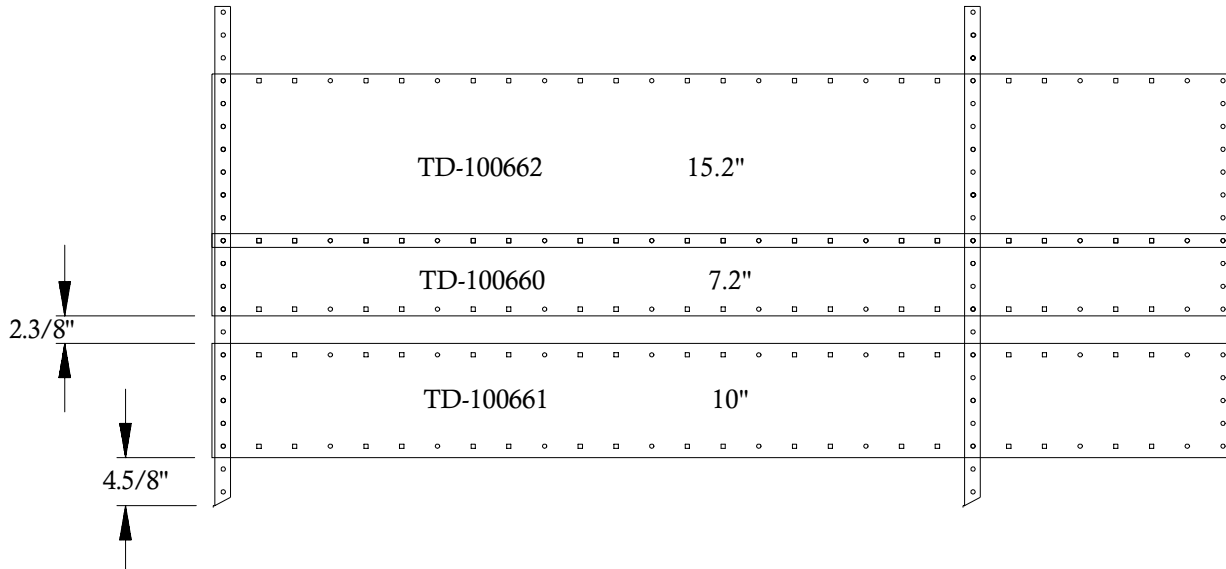

6 Band Sections per Ring
7 Bays w/ 23 Holes Between Posts

Figure #39

ROOF ASSEMBLY SPECIAL INSTRUCTIONS

It is now time to assemble the roof. The roof is assembled according to the instructions in the roof hardware box, WITH THE FOLLOWING EXCEPTIONS:

1. Locate eave clips so that a roof sheet will be centered over sidewall ladder.
2. Four eave clip shims per eave clip must be installed.
3. Use TD-100274 Roof Brackets shipped in the Top Dry hardware rather than the brackets shipped in the roof hardware.

Eave Clip Assembly

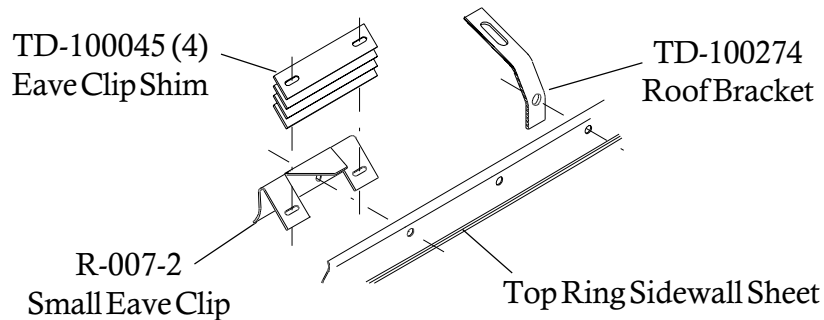

Figure #40

Note: Field cut rounded notches in the outer leveling band(s) where the two roof support channels (CRP-4692) hang from the roof ribs.

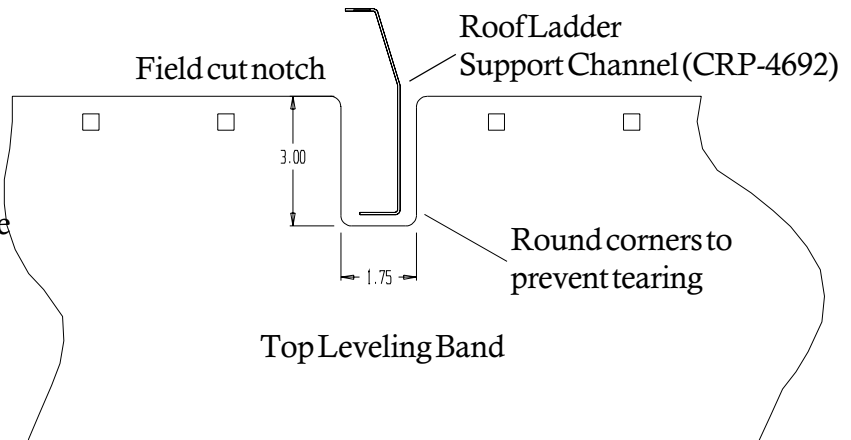

Figure #41

FAN ENTRANCE SHEETS

24" thru 36" Fans

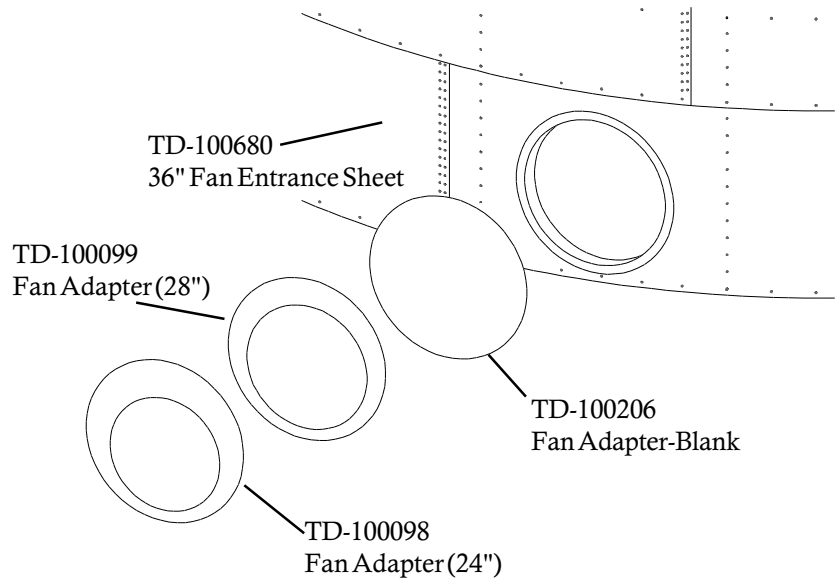

Figure #42

42" Fans

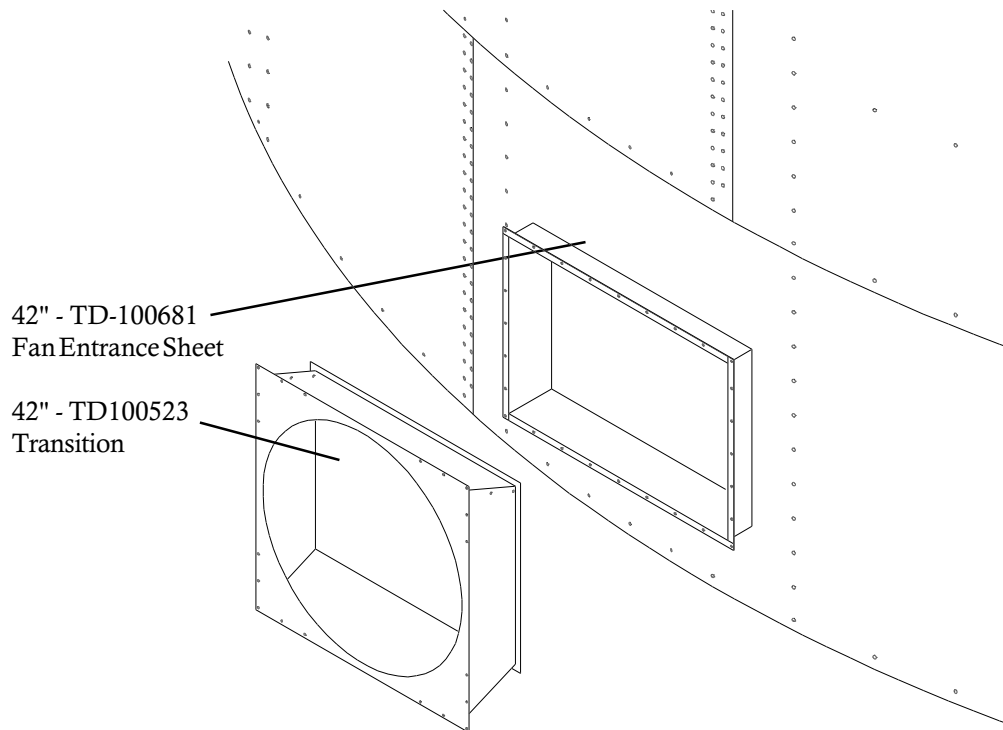
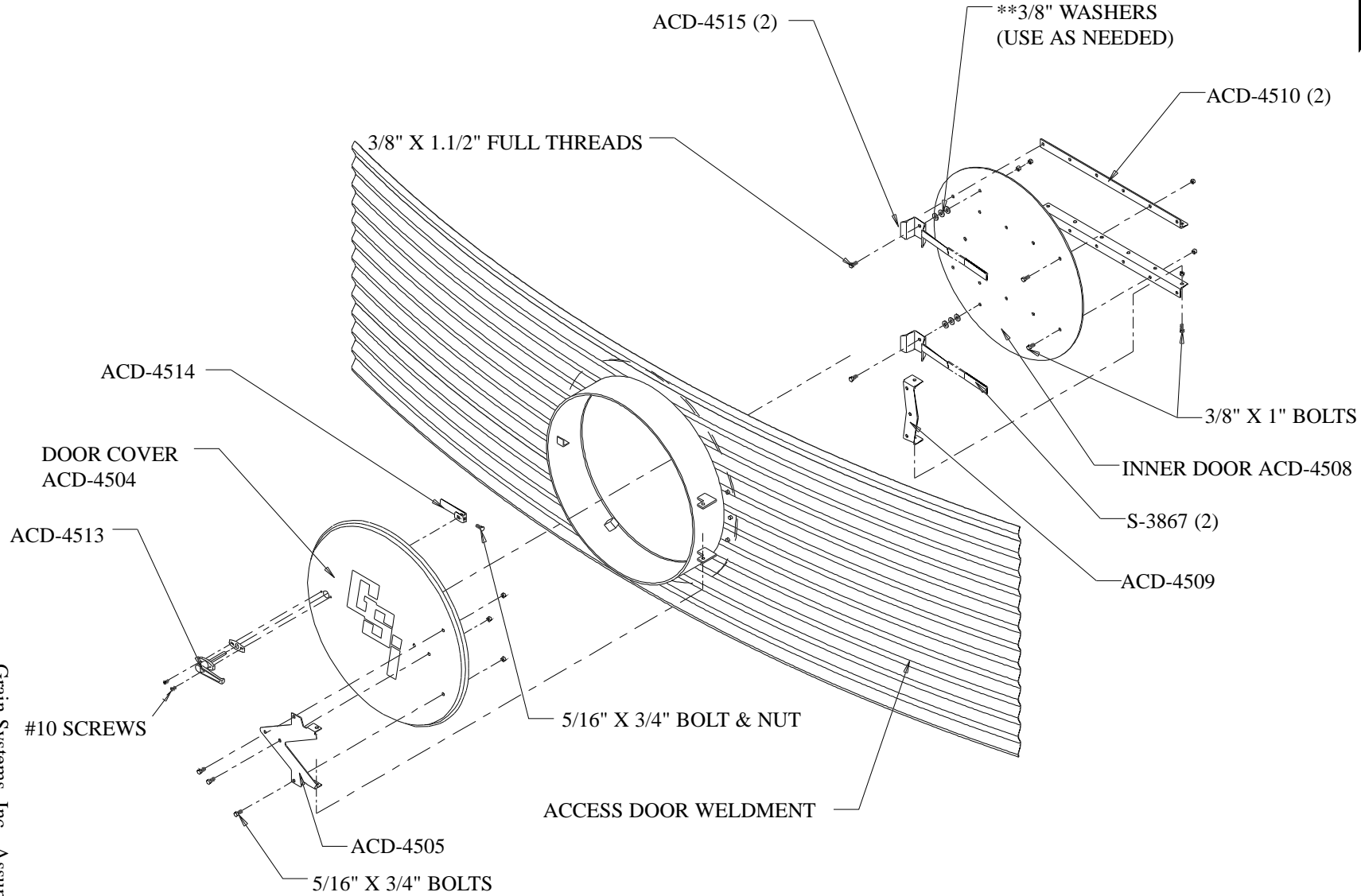

Figure #43

ACCESS DOOR WELDMENT ASSEMBLY



24' AutoFlow



****THE QUANTITY OF 3/8" WASHERS NEEDED MAY VARY DEPENDING ON THE SIDEWALL GAUGES.**

Figure #44

LIFTING JACKS & BRACKETS

NOTE: The number of lifting jacks required is best determined by personal experience. Factors such as bin size, soil compaction, wind velocity, jack design, etc., are all to be considered when deciding how many to use. If in doubt, use one jack on every other stiffener. GSI recommends heavy duty jacks rated at 6,000 lbs. or more.

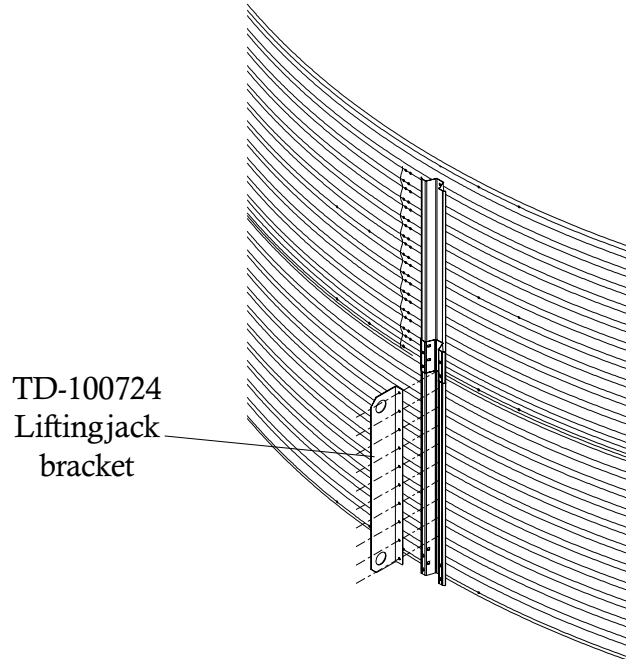

Figure #45

Remember to attach lifting brackets to the stiffeners. A special lifting bracket is available from G.S.I.

Anchor all jacks securely and raise the bin just high enough to assemble the next ring. When lifting your bin, raise all jacks at an equal rate. This will prevent the bowing of previously assembled rings and make for easier hole alignment. Bolt the next ring to the inside of the second ring. Be sure to stagger the sheets and select the proper gauge material. Lower the bin on the foundation after assembling and tightening the bolts on the new ring. Now rebolt the lifting straps, continue ring additions until you are ready for door installation.

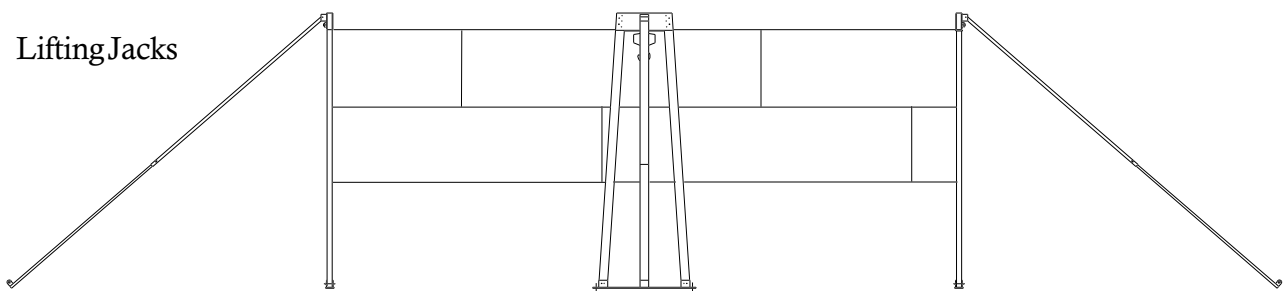
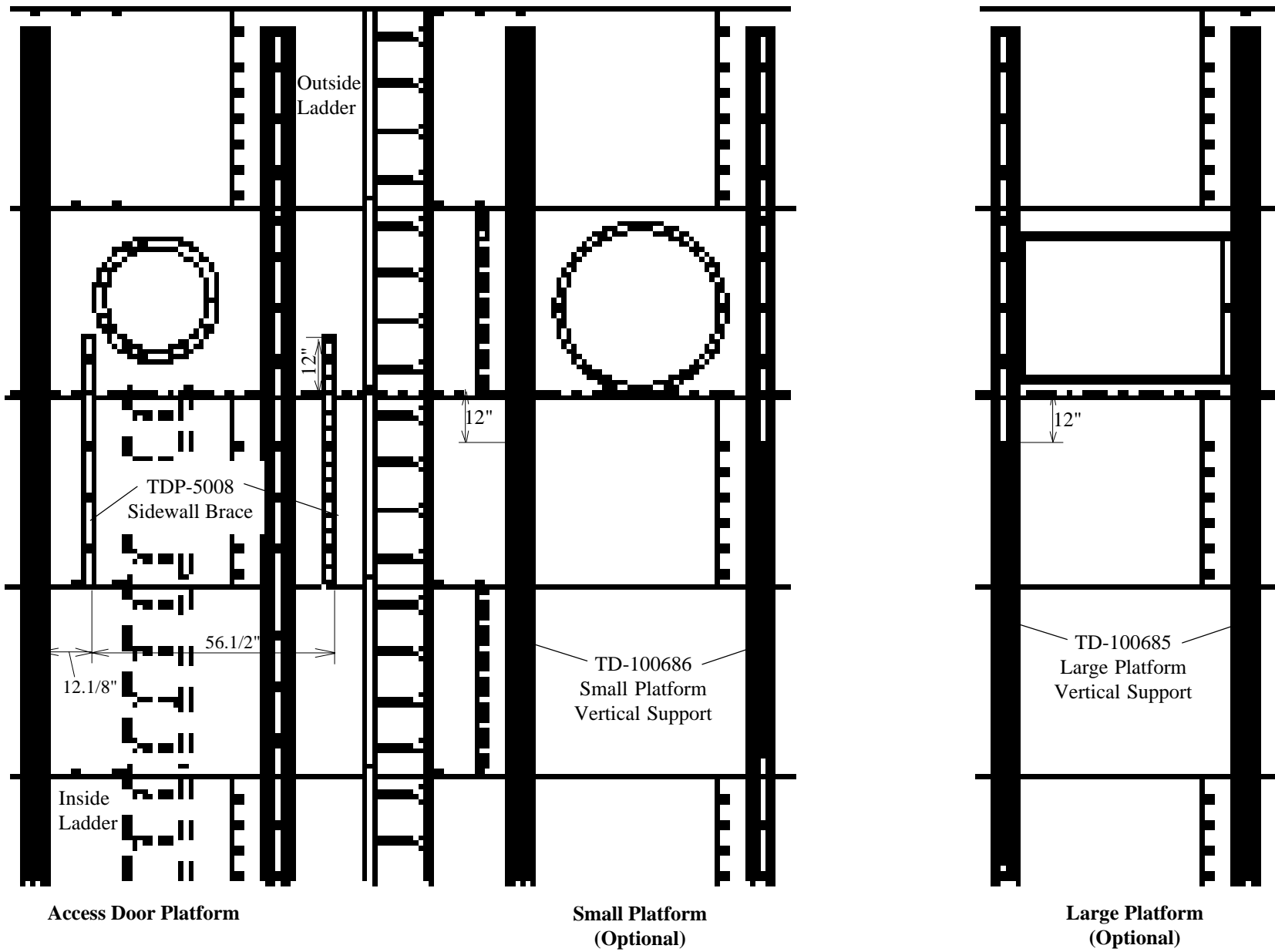

Figure #46

DETAILED LAYOUT FOR PROPER LOCATION OF PLATFORM



24' Autoflow

Small Platform (Optional)

Large Platform (Optional)

Figure #47

ACCESS DOOR PLATFORM

Before assembly of any platform, read the entire instructions to assure proper placement and assembly.

Refer to Figure #47 for proper location of access door platform. Begin by assembling the access door platform support frame using 5/16" x 3/4" truss head bolts and nuts. When attaching platform vertical support to bin sidewall field drill (16) 3/8" diameter holes for each support spaced every 4". Be sure and use 5/16" x 3/4" bin bolt on vertical support to sidewall. Special attention should be taken when assembling the platform support that the support brace is placed correctly.

Now proceed to the platform floor. Align holes on platform floor with holes on platform support and bolt together using 5/16" x 3/4" truss head bolt and nuts. Next, assemble handrail posts, handrails, and handrail braces.

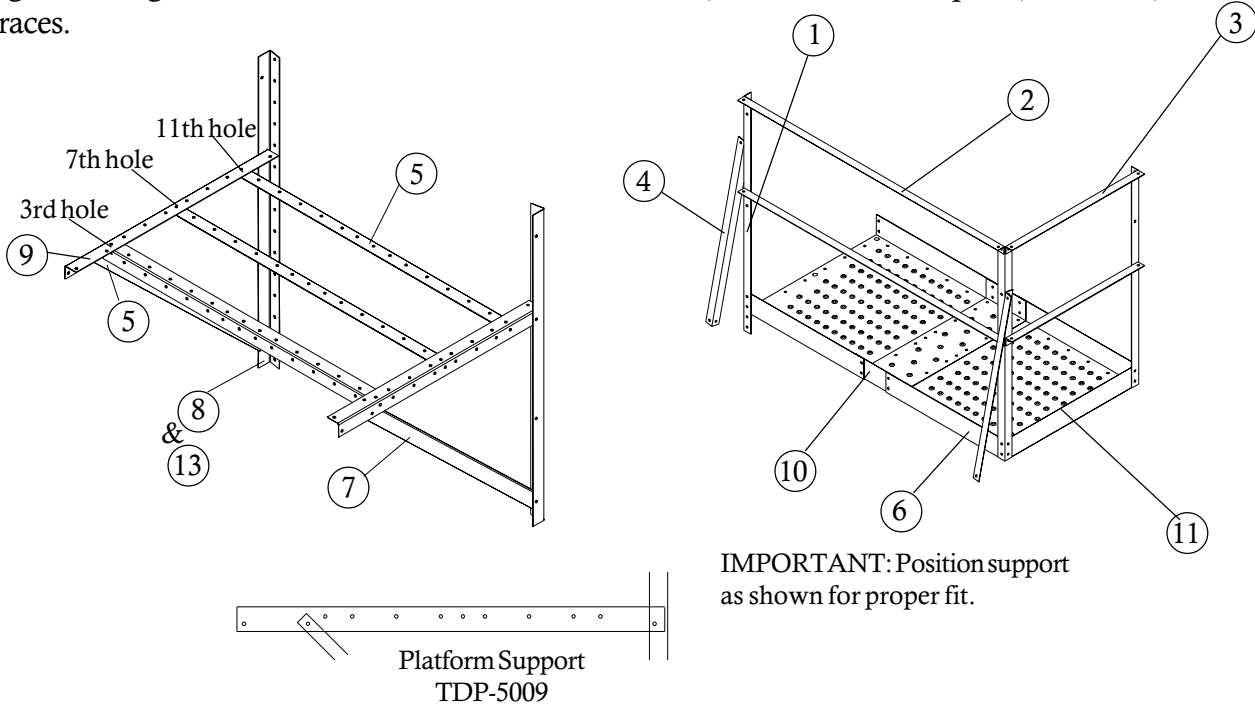

Figure #48

Key	Part No.	Description	Quantity	Weight
1	LS-371	Platform Vertical Angle 42"	3	11.38
2	TDP-5000	Handrail 59"	2	10.15
3	TDP-5002	Handrail 30"	2	10.15
4	TDP-5003	Handrail Brace 36.29/32"	2	6.34
5	TDP-5005	Floor Brace 58.1/2"	3	26.11
6	TDP-5006	Platform Floor 37.7/8"	2	38.23
7	TDP-5007	Support Brace 50.21/32"	2	15.08
8	TDP-5008	Sidewall Brace 58"	2	19.65
9	TDP-5009	Platform Support 43.1/2"	2	12.95
10	TDP-5010	Platform Floor Splice 37.1/2"	1	6.24
11	TDP-5011	Platform Toe Plate 29.3/4"	1	3.29
12	TDP-5014	Access Door Package Hardware	1	5.41
13	TDP-5008N	Sidewall Brace 2.66"	2	16.61



SMALL PLATFORM ASSEMBLY

For 36" Fans and Smaller
with #1 fan when two 36" or smaller fans are installed

Before assembling any platform, read all of the instructions first to assure proper placement and assembly.

Refer to Figure #47 for proper location of small platform. Begin by assembling the small platform support frame using 3/8" x 1" bolts on all connections. Use 5/16" x 1.1/4" bin bolt to attach platform vertical supports to sidewall stiffeners.

Be sure and locate the 5/16" x 1.1/4" bolts from the inside of the bin to the outside. This will provide maximum weather protection.

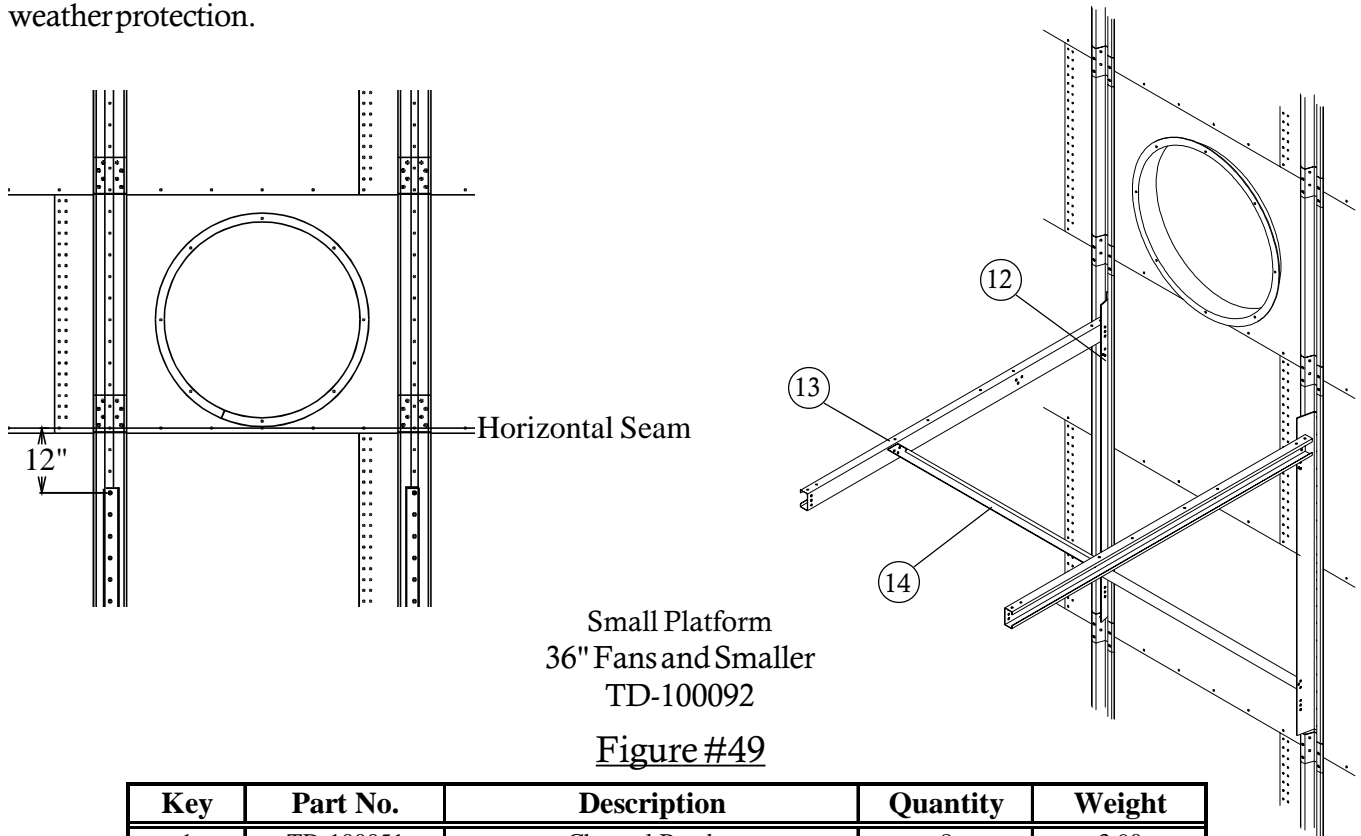

Small Platform
36" Fans and Smaller
TD-100092

Figure #49

Key	Part No.	Description	Quantity	Weight
1	TD-100051	Channel Bracket	8	3.90
2	TD-100052	Handrail Post 49.3/4"	4	31.69
3	TD-100059	Long Toeboard 78.1/2"	2	10.96
4	TD-100060	Short Toeboard 54.1/2"	1	3.80
5	TD-100061	Long Handrail 78.1/2"	4	37.52
6	TD-100062	Short Handrail 54.1/2"	2	13.02
7	TD-100064	Floor Plank 78"	11	112.87
8	TD-100066	"X" Brace Strap 60"	4	7.26
9	TD-100067	Mid Channel Support 74"	2	32.73
10	TD-100070	Side Channel Support 78.1/2"	2	41.26
11	TD-100072	End Channel Support 78.1/2"	2	41.60
12	TD-100686	Vertical Support 70"	2	43.11
13	TD-100083	Support Channel 80.7/8"	2	32.98
14	TD-100084	Knee Brace 83.5/8"	2	23.67
15	TD-100090	Small Platform Hardware Package	1	8.96

SMALL PLATFORM ASSEMBLY

36" Fans and Smaller
TD-100092

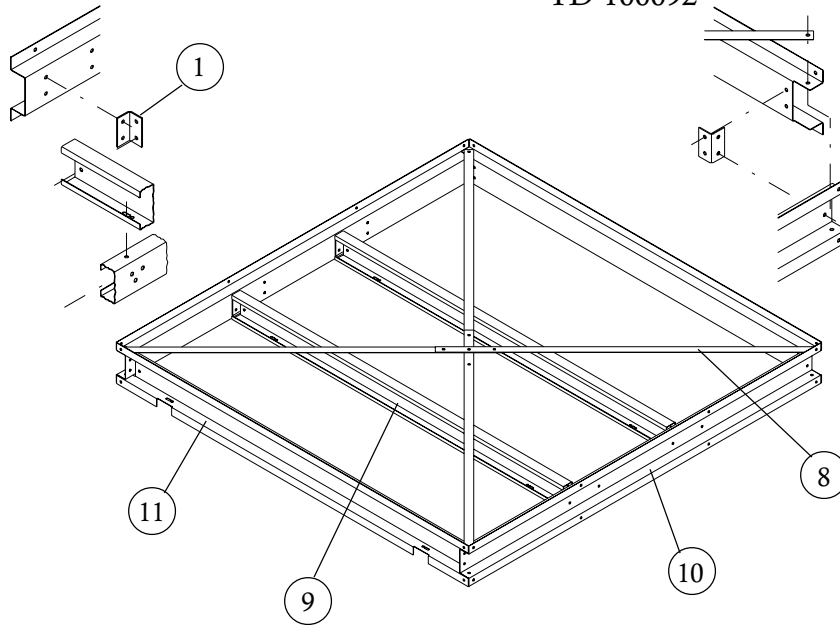

Position the vertical support to the existing sidewall stiffeners as shown in Figure #47 and double nut with 5/16" nuts.

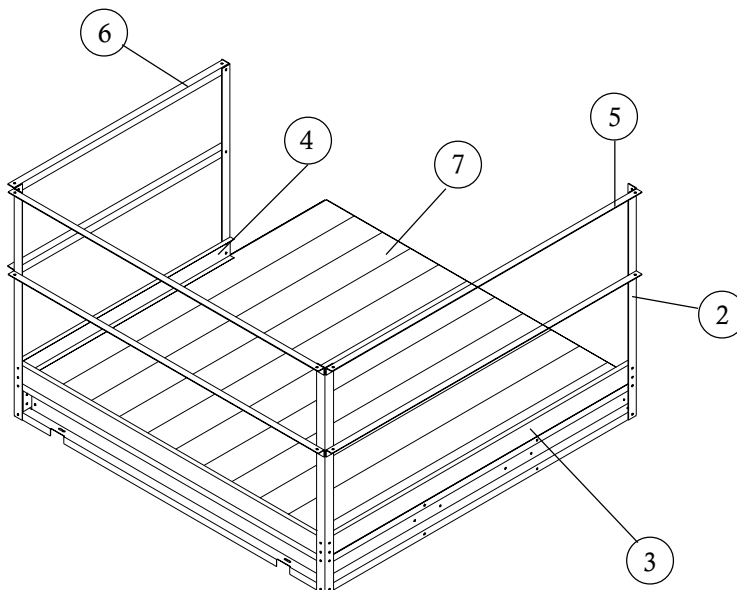

When bolting stiffener to sidewall at locations where platform supports are to be attached, use (25) 5/16" x 1.1/4" bin bolts, heads to inside. Start 12 inches below horizontal seam of second and third rings from top. See Figure #47.

Figure #50

LARGE PLATFORM ASSEMBLY

For 42" Fan

Before assembly of any platform, read the entire instructions to assure proper placement and assembly.

Refer to Figure #47 for proper location of large platform. Begin by assembling the large platform support frame using 7/16" x 1" bolts on all connections. Use 5/16" x 1.1/4" bin bolt to attach the platform vertical supports to the sidewall stiffeners. Be sure and place the 5/16" x 1.1/4" bolts from the inside of the bin to the outside. This will provide maximum weather protection.

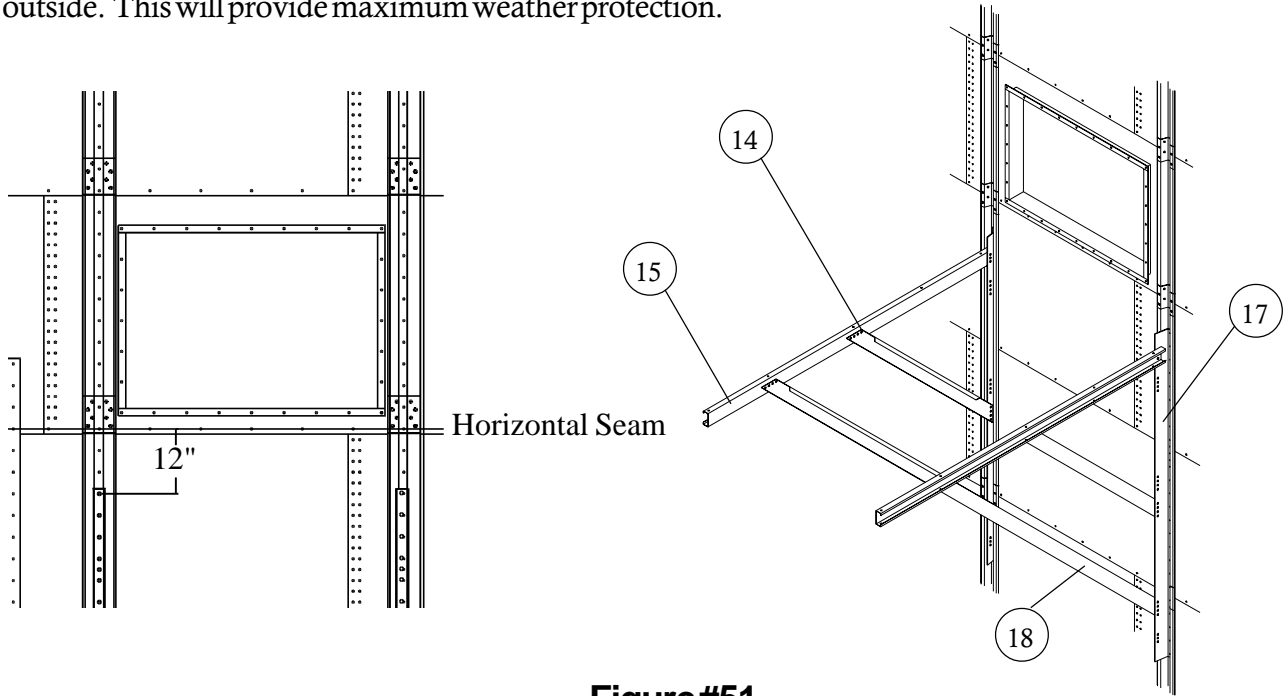

Figure#51

Key	Part No.	Description	Quantity	Weight
1	TD-100051	Channel Bracket	10	4.87
2	TD-100052	Handrail Post 49.3/4"	7	55.47
3	TD-100053	Toeboard 71.1/2"	1	4.99
4	TD-100054	Toeboard 92"	1	6.42
5	TD-100055	Toeboard 95.1/2"	1	6.67
6	TD-100056	Handrail 71.1/2"	2	17.07
7	TD-100057	Handrail 92"	2	22.98
8	TD-100058	Handrail 95.1/2"	2	22.81
9	TD-100063	Floor Plank 95.1/2"	13	163.35
10	TD-100065	"X" Brace Strap 94.5/16"	2	8.75
11	TD-100068	Mid Channel Support 88"	3	58.37
12	TD-100069	Side Channel Support 96"	2	50.46
13	TD-100071	End Channel Support 92.1/2"	2	49.15
14	TD-100085	Short Knee Brace 72.9/32"	2	54.51
15	TD-100086	Support Channel 98.3/8"	2	53.08
16	TD-100087	Long Knee Brace 114"	2	85.98
17	TD-100685	Vertical Support 94"	2	63.64
18	TD-100091	Large Platform Hardware Package	1	14.35

LARGE PLATFORM ASSEMBLY
 (FOR 1 FAN SYSTEMS OR #2 FAN ON 2 FAN SYSTEMS)

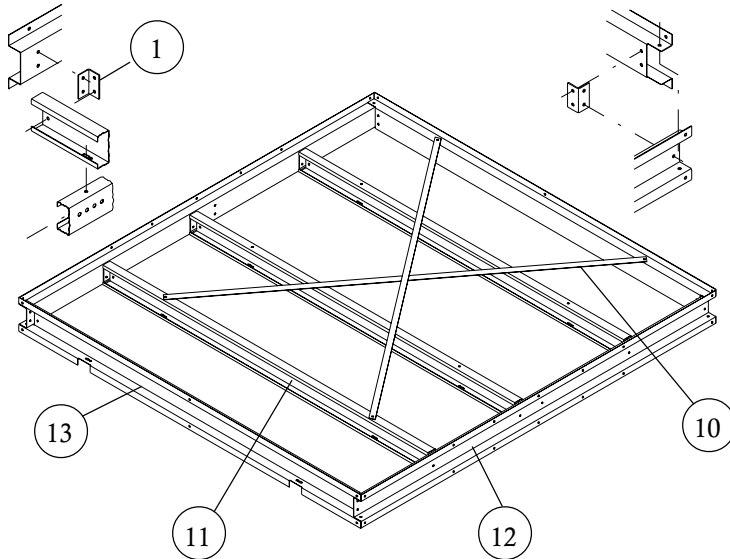

Position the vertical support to the existing sidewall stiffeners as shown in Figure #47 and double nut with 5/16" nuts.

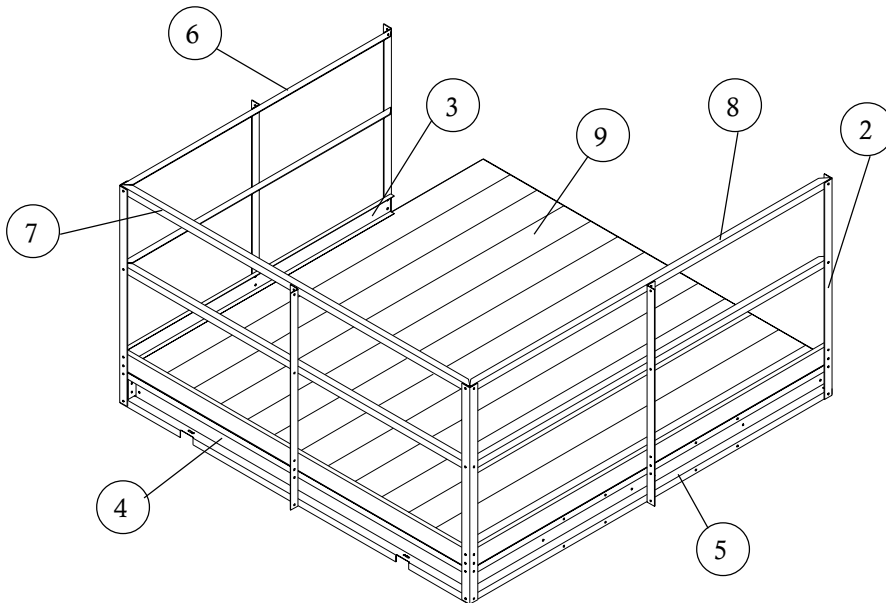

When bolting stiffener to sidewall at locations where platform supports are to be attached, use (25) 5/16" x 1.1/4" bin bolts, heads to inside. Start 12 inches below horizontal seam of second and third rings from top. See Figure #47.

Figure#52



CROSS OVER PLATFORM ASSEMBLY (For use with stairs)

TDP-5013

Before assembly of any platform, read the entire instructions to assure proper placement and assembly.

Refer to Figure #47 for proper location of cross over platform. Begin by assembling the cross over platform support frame using 5/16" x 3/4" truss head bolts and nuts. When attaching platform vertical support to bin sidewall field drill (16) 3/8" diameter holes for each support spaced every 4". Be sure and use 5/16" x 3/4" bin bolt on vertical support to sidewall. Special attention should be taken when assembling the platform support that the support brace is placed correctly.

Now proceed to the platform floor. Align holes on platform floor with holes on platform support and bolt together using 5/16" x 3/4" truss head bolt and nuts. Next, assemble handrail posts, handrails, and handrail braces.

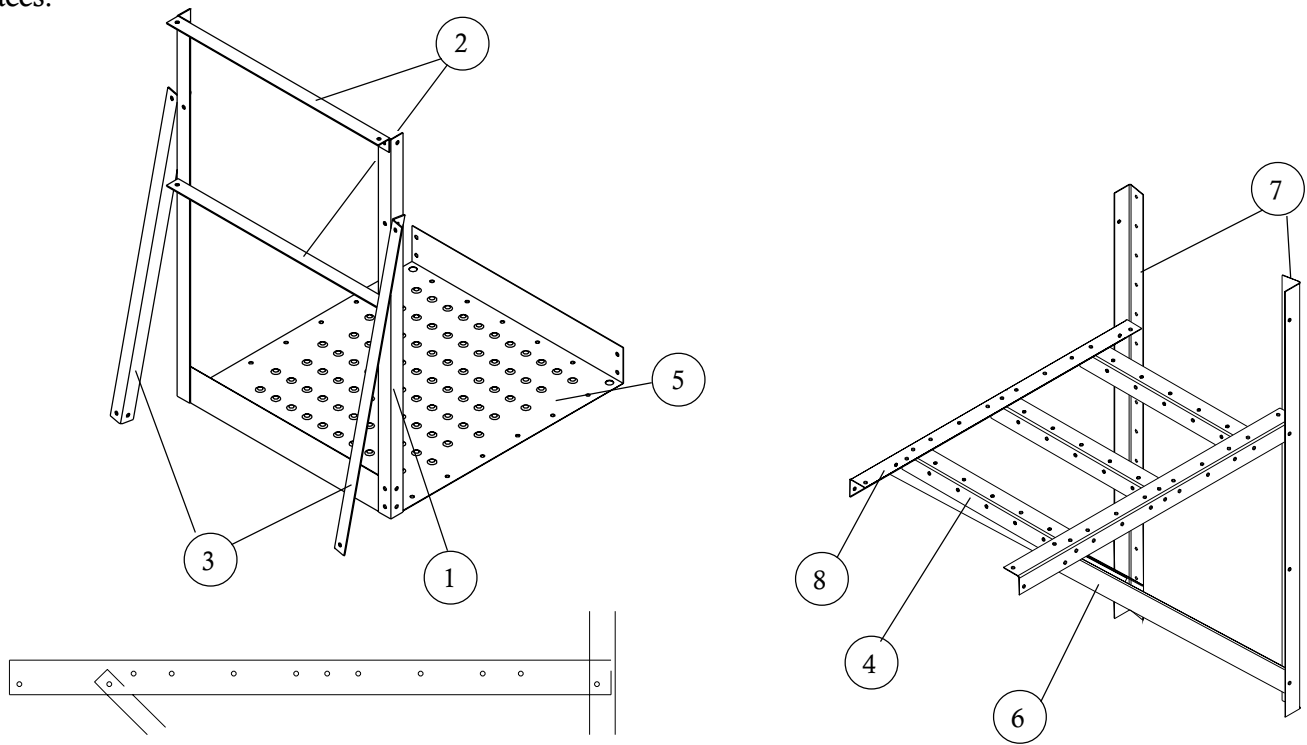

Figure#53

Key	Part No.	Description	Quantity	Weight
1	LS-371	Platform Vertical Angle	2	7.59
2	TDP-5001	Handrail 27"	2	4.63
3	TDP-5003	Handrail Brace 36.29/32"	2	6.34
4	TDP-5004	Short Floor Brace 26.1/2"	3	11.85
5	TDP-5006	Platform Floor 37.7/8"	1	19.11
6	TDP-5007	Support Brace 50.21/32"	2	15.08
7	TDP-5008	Sidewall Brace 58"	2	19.65
8	TDP-5009	Platform Support 43.1/2"	2	12.95
	TDP-5015	Cross Over Plat. Hdw. Pack.	1	3.95

PERFORATED CENTER BAND

Drill (6) 3/8" diameter holes equally spaced as shown above for top band clips. Attach clips using 5/16" x 3/4" bin bolts. Add perforated band sections. Note that these do not attach to the leveling bands but hang down on the inside of the top inner leveling band.

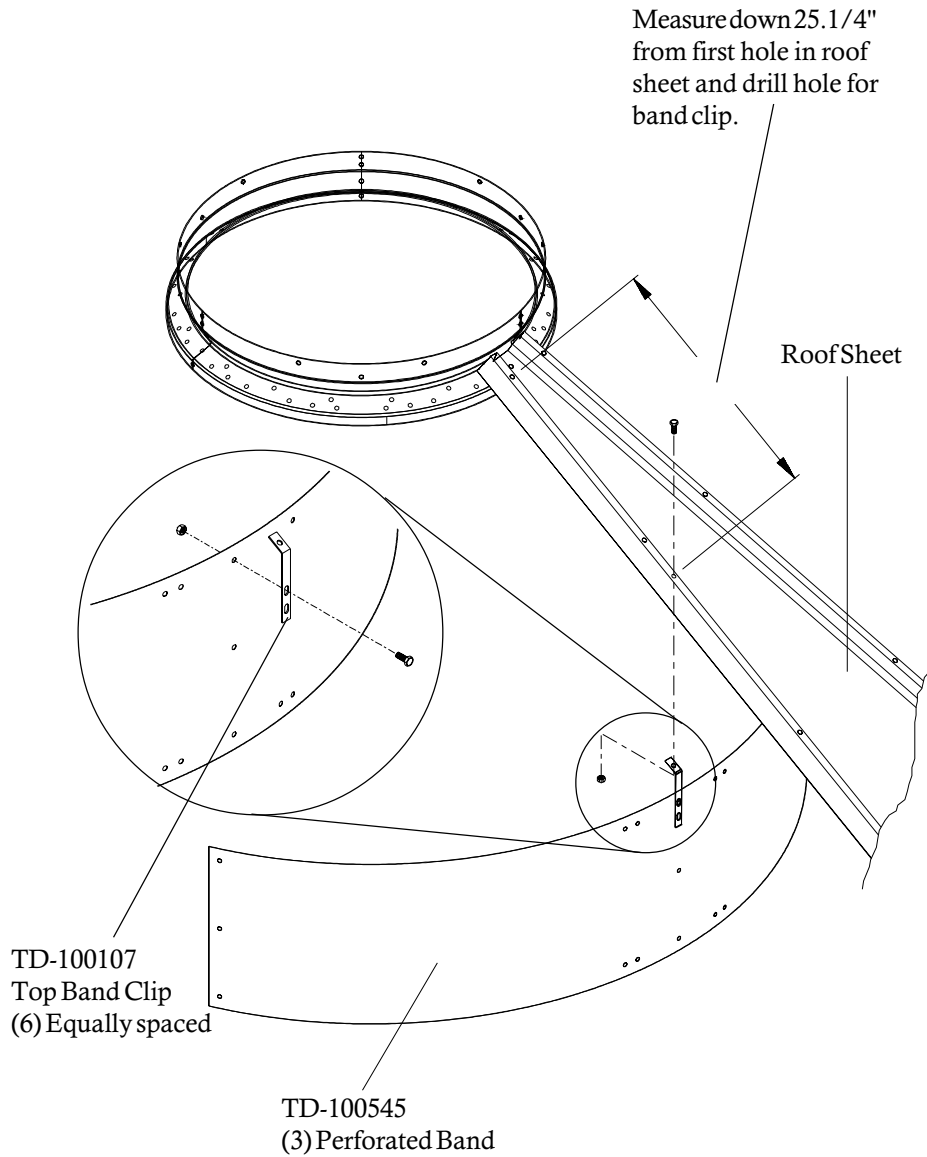
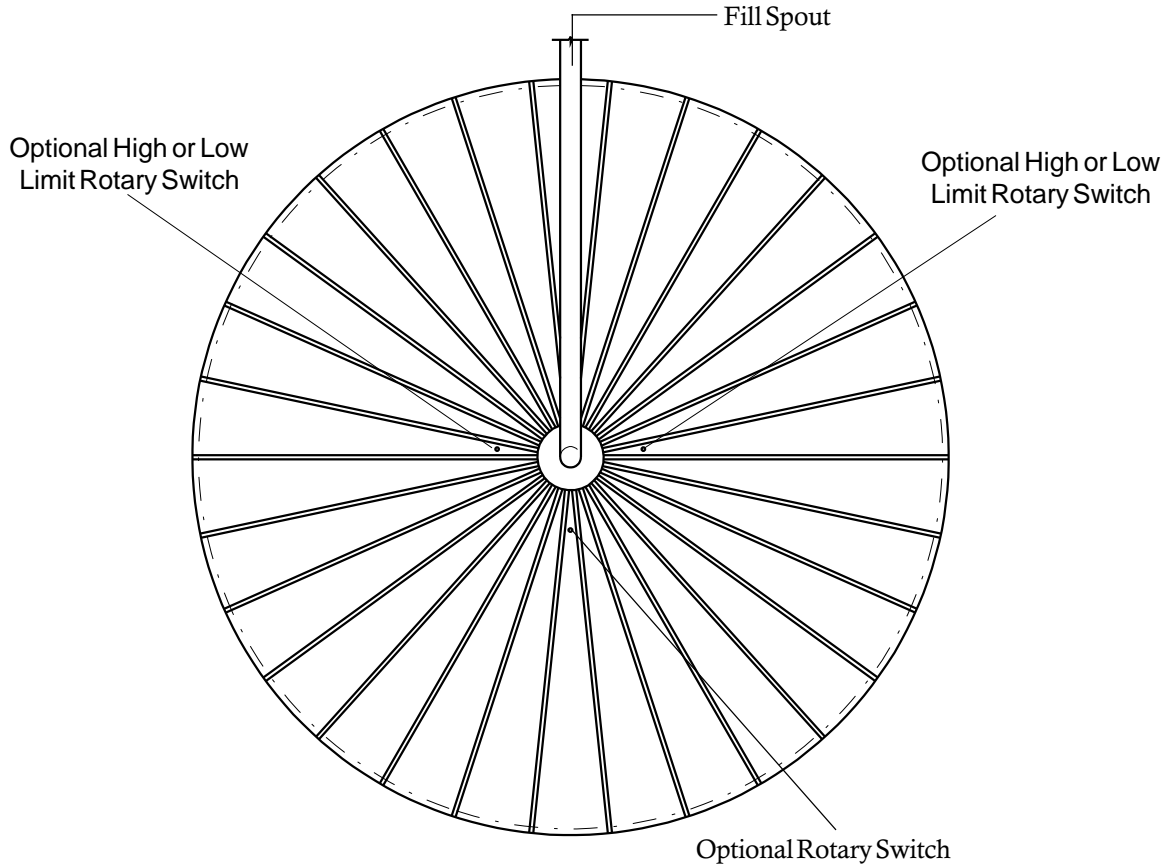

Figure #54

OPTIONAL ROTARY SWITCH ROOF LOCATIONS

Overhead View of optional rotary Switch Locations



ROTARY SWITCH PANEL LOCATION

Drill 2" diameter holes through roof panels at locations shown on previous page. Use a mounting plate as a pattern and drill (4) 3/8" holes through roof panels at each switch location so the plate can be bolted to the roof.

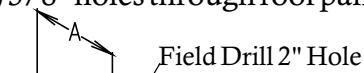

Top Dry Bin Diameter	"A"
24'	23.50"

Figure#55

INSTALLATION OF ROOF-MOUNTED LEVEL SWITCH

Drill 2" diameter holes through roof panels at locations shown on previous page. Use a mounting plate as a pattern and drill (4) 3/8" holes through roof panels at each switch location so the plate can be bolted to the roof.

Attach flex-coupling to the power-pak and install roll pin. Apply teflon tape or pipe sealant (not included) to power-pak pipe threads and thread power-pak into mounting plate coupling. Conduit opening in power-pak should be at right angles to roof rib or face toward eave.

Caulk underside of mounting plate above and both sides of 2" hole. Bolt to roof panel.

OverFlow Level Switch
TAF-6103

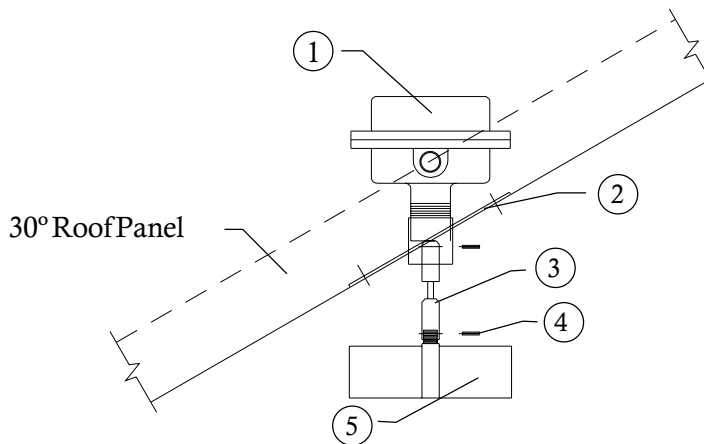

Figure#56

Key	Part No.	Description	Quantity	Weight
1	TD-100076	Rotary Switch Power-Pak	1	3.50
2	TD-100627	Roof Mount Coupling Weldment	1	2.14
3	TD-100075	Flex-Coupling	1	0.50
4	S-7241	1/8" x 1.1/4" Cotter Pin	2	0.02
5	TAF-6086	3-Vane Paddle	1	0.75
*	TAF-6097	Hardware Package	1	0.98
--	PNEG-300	Rotary Switch Instructions	1	0.04
--	S-275	5/16" - 18 x 3/4" Bin Bolt	6	0.16
--	S-3651	Tube Seal	1	0.74
--	S-396	5/16" - 18 Hex Nut	6	0.06
--	S-7241	1/8" x 1.1/4" Cotter Pin	2	0.02

* Hardware Package not shown

- Included in Hardware Package

INSTALLATION OF WALL-MOUNTED ROTARY SWITCHES

Note: Wall mounted switch must be located at least 3' below the fan opening.

Drill 2" hole through wall 3' below the upper fan and heating unit(s). IF BIN IS 2.66" corrugation, hole should be centered on outside hill (see Figure #54 below) IF BIN IS 4.00" corrugation, hole should be centered on outside valley.

Position mount plate (from inside), mark and drill 3/8" holes. Caulk coupling abundantly where it passes through the wall. Add foam weather strip around top and sides of plate then bolt to bin wall. Caulk coupling to wall from outside. Attach flex coupling to power-pak. Add teflon tape or pipe (sealant not included) to power-pak pipe threads and thread into coupling. Conduit opening should be horizontal or down. Add one-vane paddle.

Wall Mount Rotary Switch
TAF-6106

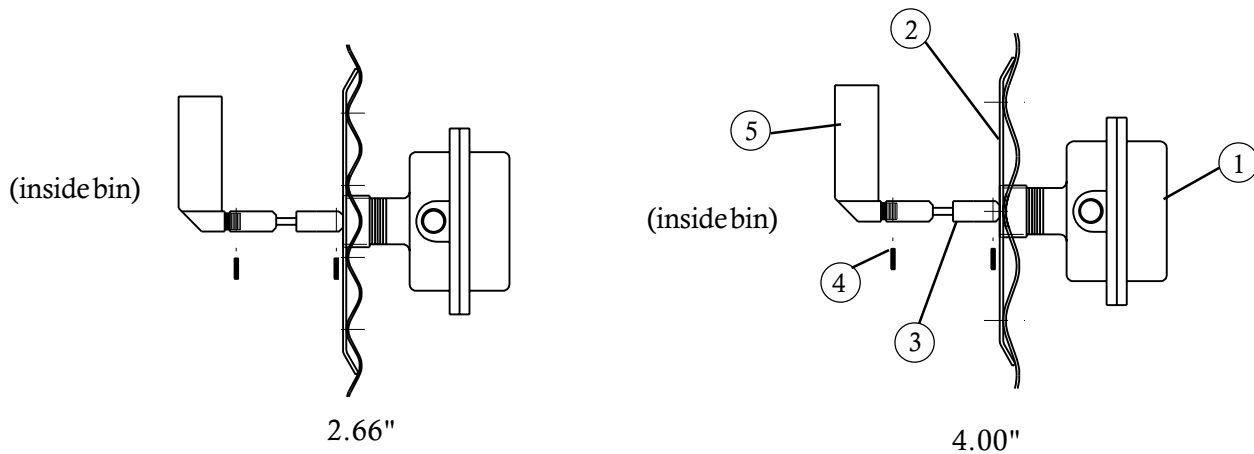

Figure #57

Key	Part No.	Description	Quantity	Weight
1	TD-100076	Rotary Switch Power-Pak	1	3.50
2	TD-100629	Roof Mount Coupling Weldment	1	2.14
3	TD-100075	Flex-Coupling	1	0.50
4	S-7241	1/8" x 1.1/4" Cotter Pin	2	0.02
5	TAF-6085	1-Vane Paddle	1	0.75
*	TAF-6097	Hardware Package	1	0.98
--	PNEG-300	Rotary Switch Instructions	1	0.04
--	S-275	5/16" - 18 x 3/4" Bin Bolt	6	0.16
--	S-3651	Tube Seal	1	0.74
--	S-396	5/16" - 18 Hex Nut	6	0.06
--	S-7241	1/8" x 1.1/4" Cotter Pin	2	0.02

ASSEMBLY OF HIGH/LOW LIMIT ROTARY SWITCHES

Attach flex-coupling to the power-pak. Apply teflon tape or pipe sealant (not included) to power-pak pipe threads and thread power-pak into mounting plate coupling. Conduit opening in power-pak should be at right angles to roof rib or face toward eave. Caulk underside of mounting plate above and both sides of 2" hole. Bolt to roof panel. Attach shaft extension according to diagram at left. Use teflon tape or pipe sealant (not included) on shaft guard and thread to underside of mount plate coupling. Add 1/4" drilled coupling and paddle. (Note: single vane paddle is used on Low level switch. Also, be sure to use roll pins when instructed. If cotter pins are used, bend back fully to reduce shaft guard interference to rotation.)

Low Limit Rotary Switch
TAF-6100

High Limit Rotary Switch
TAF-6103

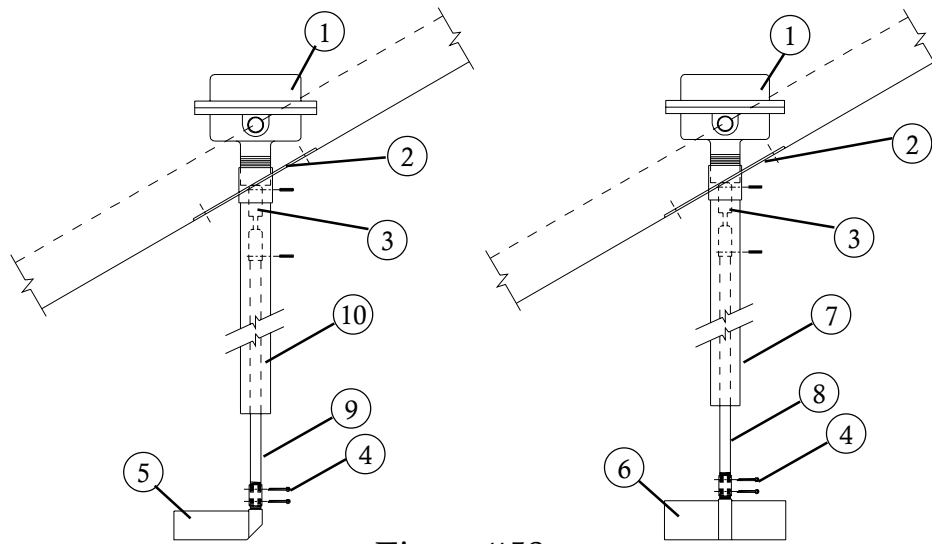

Figure #58

Key	Part No.	Description	Quantity	Weight
1	TD-100076	Rotary Switch Power-Pak	1	3.50
2	TD-100629	Roof Mount Coupling Weldment	1	2.14
3	TD-100075	Flex-Coupling	1	0.50
4	S-7241	1/8" x 1.1/4" Cotter Pin	2	0.02
5	TAF-6085	1-Vane Paddle	1	0.75
6	TAF-6086	3-Vane Paddle	1	0.75
7	TAF-6091	8" Shaft Guard	1	0.81
8	TAF-6092	5" Shaft Extension	1	0.20
9	TAF-6094	34" Shaft Extension	1	1.52
10	TAF-6093	34" Shaft Guard	1	2.04
*	TAF-6096	Hardware Package	1	0.98
--	PNEG-300	Rotary Switch Instructions	1	0.04
--	S-275	5/16" - 18 x 3/4" Bin Bolt	6	0.16
--	S-3651	Tube Seal	1	0.74
--	S-396	5/16" - 18 Hex Nut	6	0.06
--	S-7241	1/8" x 1.1/4" Cotter Pin	2	0.02



TRANSITION INSTALLATION (TR-4734)

BEFORE CUTTING THE OPENING CHECK THAT TR-4734 IS THE TRANSITION THAT WAS ORDERED.

When installing the GSI aeration transition, it will be necessary to field cut a hole into the bottom sidewall ring (usually straight across from the unload auger). Refer to diagram for proper dimensions of cutout. The base angle will also need to be cut at entrance collar cutout. Take note of the diagram showing the 1" dimension from bottom of entrance collar side bracket to concrete. This is important for proper fit of transition.

NOTE: Entrance collar side bracket must be bolted on the inside of the bin sidewall.

AS VIEWED FROM INSIDE BIN

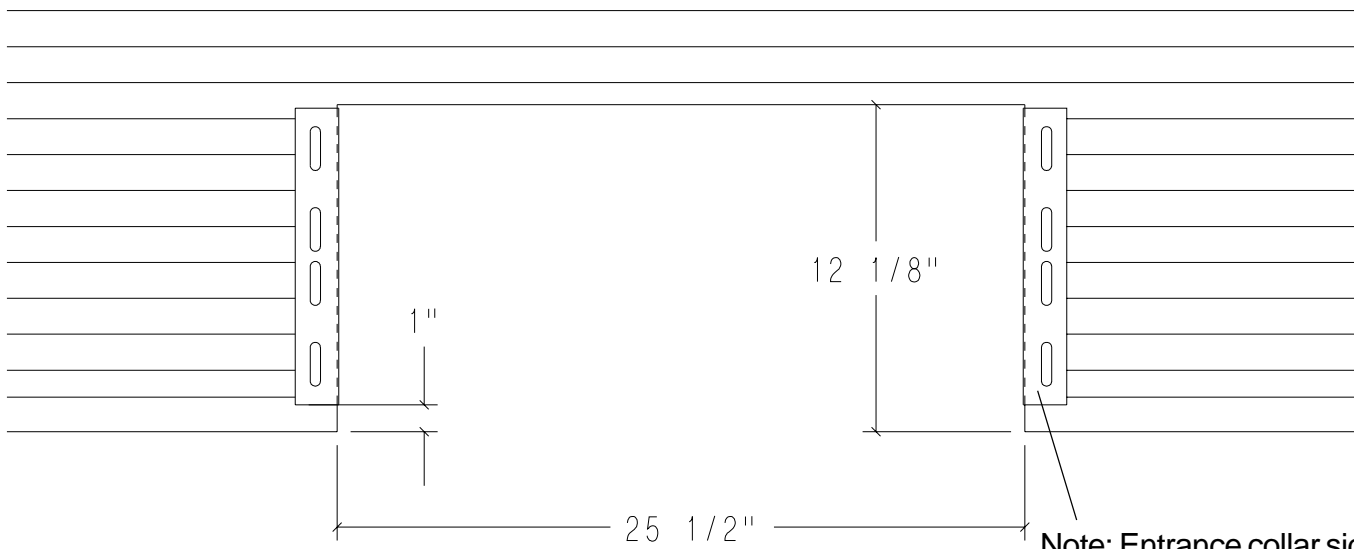

Note: Entrance collar side bracket (TR-4731) flange must be installed to the inside of the bin sidewall.

Figure #59

Part No.	Description	Quantity
S-275	5/16" - 18 3/4" Bin Bolt Grade 5	125
S-280	#10 - 16 x 5/8" Self Drill Screw	10
S-3651	Tube Caulk - Gray Butyl #506-15	1
S-396	5/16" - 18 Hex Nut Grade 2	125
S-7264	Spec Neoprene Seal Strip W/ADH	10 Ft

TRANSITION ASSEMBLY TR-4734

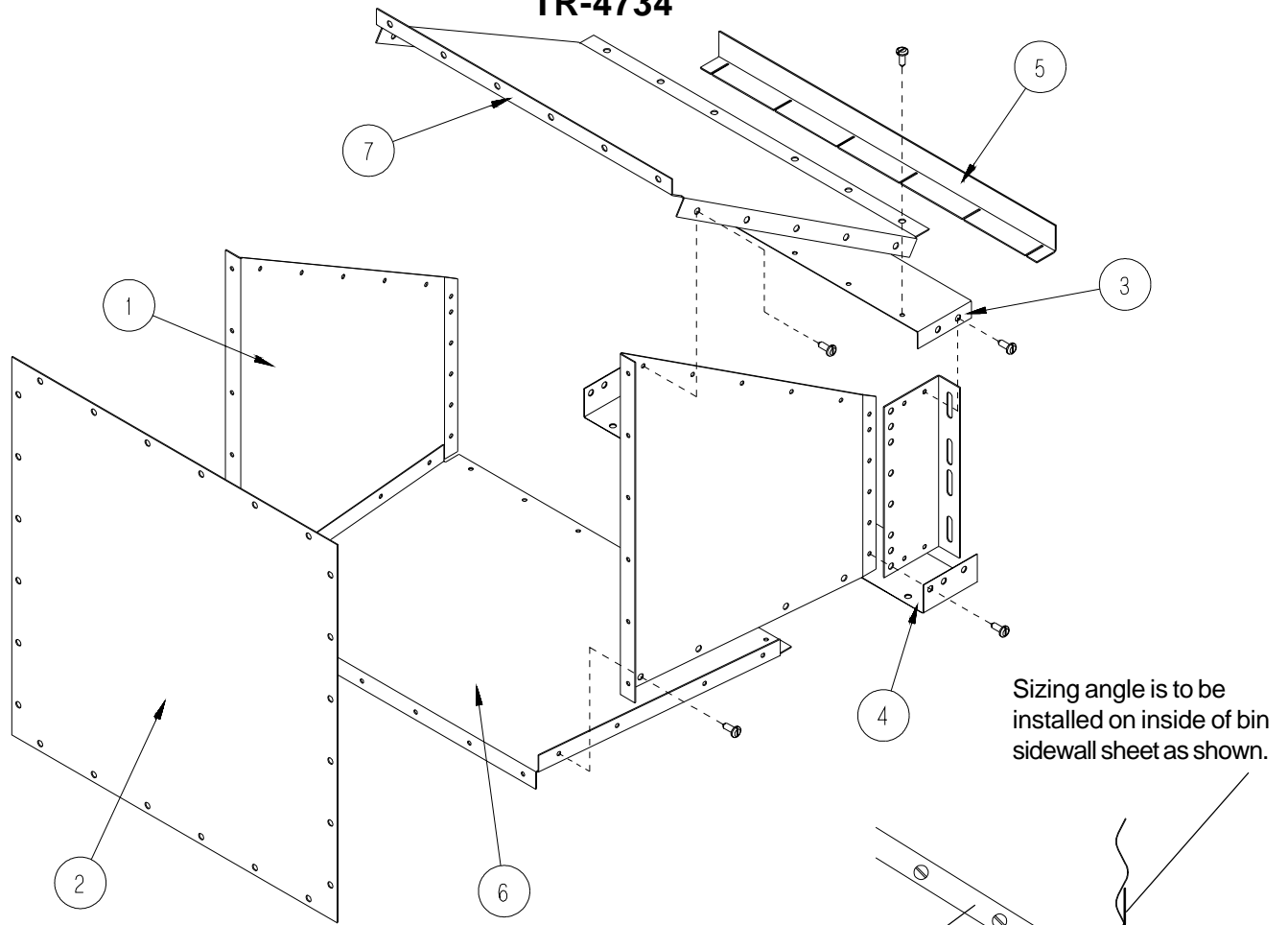

* Hardware Package not shown

- Included in Hardware Package

The flanges on transition top are to go on the outside of transition sides. The flanges on transition bottom are to go on the inside of transition sides.

Key	Part Number	Description
1	TR-4724-1	Transition side
1	TR-4724-2	Transition side
2	TR-4767	Transition faceplate
3	TR-4726	Top entrance collar piece
4	TR-4727	Bottom entrance collar
5	TR-4728	Sizing angle
6	TR-4729	Transition bottom
7	TR-4730	Transition top
8	TR-4731	Entrance collar side bracket

Figure #60

TWO RING DOOR INSTALLATION INSTRUCTIONS

Before starting to install, be sure the correct door has been received.

4.00" Corrugation

WD-6133 24' Bins

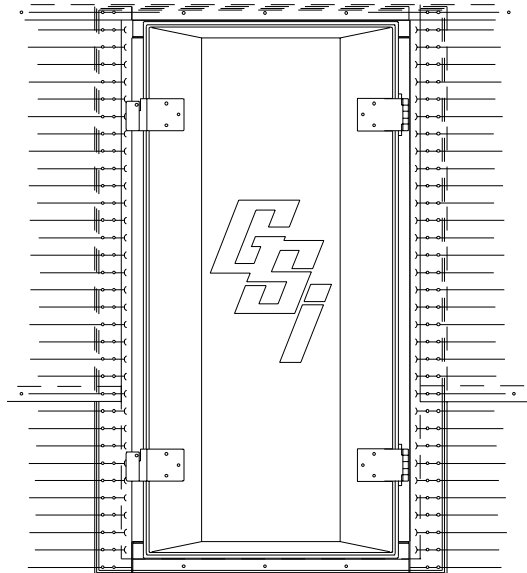
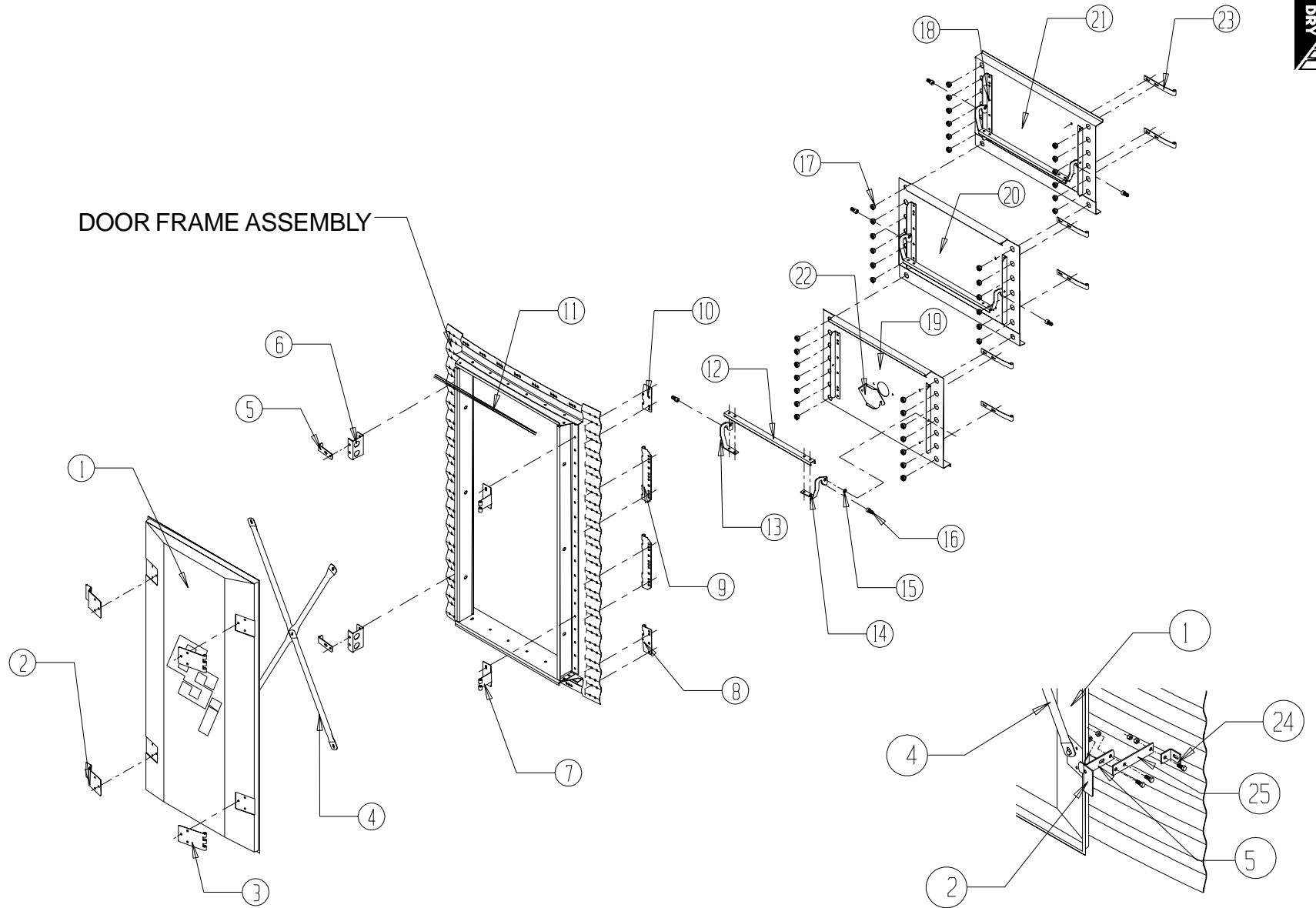

Figure #61

- 1.) Remove inner door panels, and outer door cover. Apply double row of rope caulk along door flanges, noting how door and bin sheets lap. The top of the door frame goes to the inside of the sidewall and the bottom of the door frame goes to the outside of the sidewall sheet. With inner door panels and outer door cover removed set door frame into opening. **Insert a bolt at the (4) corners of door frame and sidewall, do not tighten until completing step #2.**
- 2.) Reinstall inner door panels at original locations. Close latch bars to lock panels in place. Be sure that panels are fully seated over all bearing pins. Install inner panel hinge assemblies per illustration instructions with hinges. **Note: do not distort door frame with use of alignment or drift punches - if necessary, drill or ream holes to insert bolts in door frame. Now tighten frame bolts starting at center and working toward top and bottom on each side.**
- 3.) Keep inner panels latched and loosen all bearing pin bolts. Retighten all bearing pin bolts. This makes loading on pins uniform for easier operation of panels.
- 4.) If some latch bars are loose or require excessive force to lock, loosen hex socket capscrews and adjust in or out until latch bars operate smoothly. Check that the panels are fully seated over all bearing pins.
- 5.) Re-install outer cover. Adjust outer door hinges and latches as required.
- 6.) Assemble door holdback as shown on next page. Open door cover until it approaches the bin wall. Hook retaining bracket over lower latch mount and position the door hold back against bin wall in a valley. Drill a 3/8" hole through the bin wall and bolt the door hold back to the bin.

2-RING DOOR ASSEMBLY



DOOR FRAME ASSEMBLY

Figure #62

DOOR HOLD BACK DETAIL

PARTS LIST FOR 2-RING DOORS



24' AutoFlow

KEY	DESCRIPTION	PART NUMBER	PART NUMBER	QUANTITY	QUANTITY
		12'-27' BIN DIA.	30'-60' BIN DIA.	12'-27' BIN	30'-60' BIN
		4.00" CORR.	4.00" CORR.	DIAMETER	DIAMETER
1	OUTER DOOR COVER	WD-039	WD-039	1	1
2	OUTER COVER LATCH BRACKET	WD-2854	WD-2854	2	2
3	OUTER COVER HINGE BRACKET	WD-225	WD-225	2	2
4	DOOR COVER BRACE SECTION	WD-035	WD-035	4	4
5	DOOR RETAINER	WD-033	WD-033	3	3
6	OUTER COVER LATCH MOUNT BASE	WD-6124	WD-6124	2	2
7	OUTER COVER HINGE BASE	WD-6066	WD-6066	2	2
8	BOTTOM INNER DOOR HINGE	WD-6055	WD-6055	1	1
9	MIDDLE INNER DOOR HINGE	WD-6056	WD-6056	2	2
10	TOP INNER DOOR HINGE	WD-6054	WD-6054	1	1
11	RUBBER TRIM SEAL STRIP	S-4380	S-4380	2.1/4 FT.	2.1/4 FT.
12	LATCH BAR	WD-6039	WD-6039	3	3
13	INNER PANEL LATCH - RIGHT HAND	WD-6037	WD-6037	3	3
14	INNER PANEL LATCH - LEFT HAND	WD-6038	WD-6038	3	3
15	1/2" X 1" HEX SOCKET CAPSCREW	S-7160	S-7160	6	6
16	LATCH BUSHING	WD-6040	WD-6040	6	6
17	LONG BEARING PIN	WD-6079	WD-6079	38	38
18	INNER PANEL REINFORCING ANGLE	WD-6125	WD-6125	6	6
19	BOTTOM INNER DOOR PANEL	WD-6128	WD-6128	1	1
20	MIDDLE INNER DOOR PANEL	WD-6127	WD-6127	1	1
21	TOP INNER DOOR PANEL	WD-6126	WD-6126	1	1
22	BOTTOM INNER DOOR PORT HOLE COVER	WD-6028	WD-6028	1	1
23	INNER DOOR HINGE STRAP	WD-6053	WD-6053	6	6
24	DOOR HOLD BACK BRACKET	WD-1302	WD-1302	1	1
25	DOOR HOLD BACK EXTENSION	WD-6110	WD-6110	1	1

OPTIONAL BIN STEP ASSEMBLY

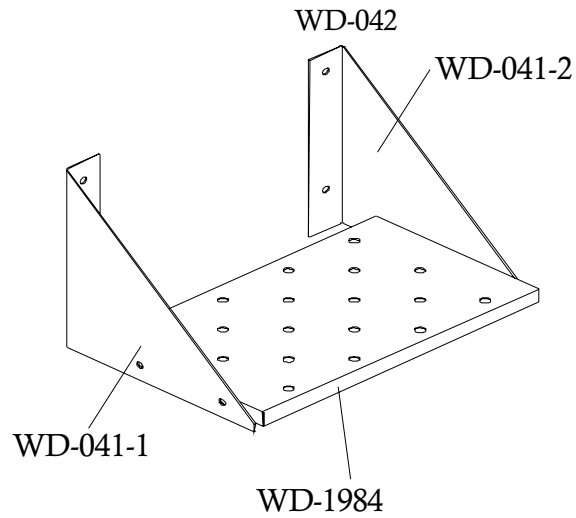

Field drill holes in sidewall
sheet on ridge of corrugation.

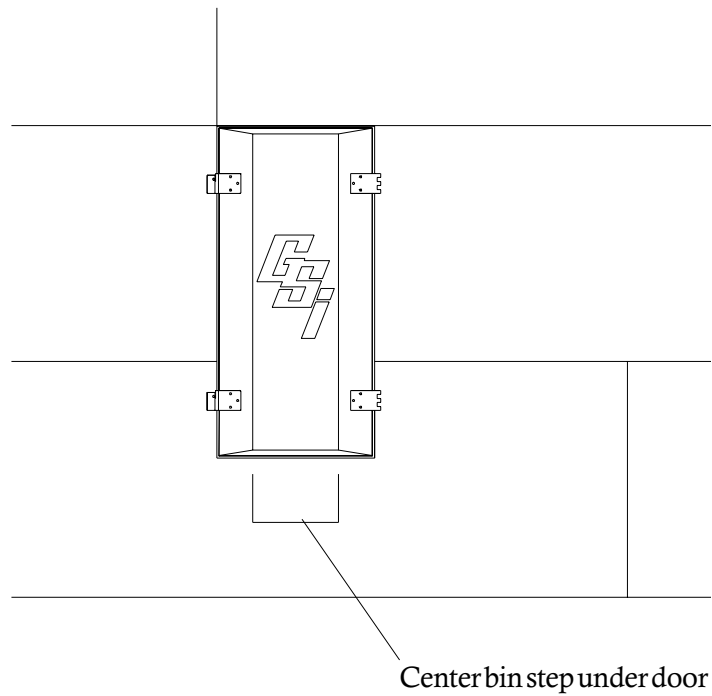
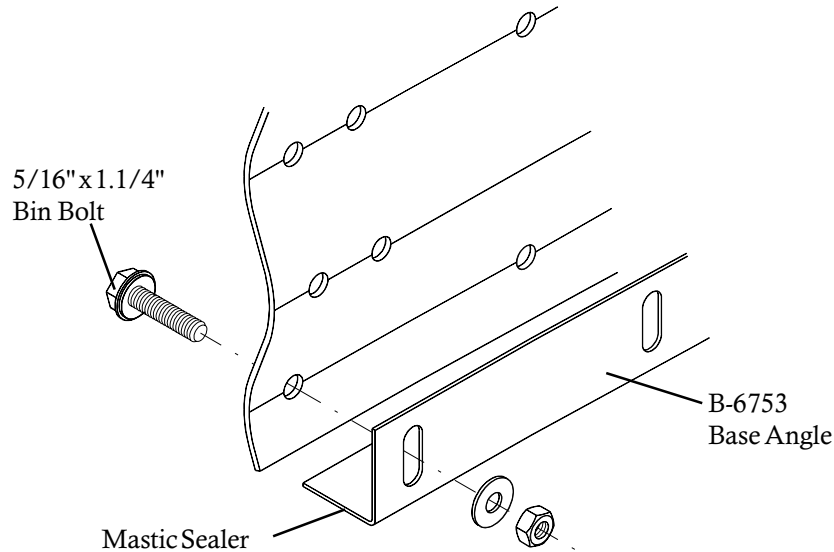

Figure #63

BASE ANGLE

B-6753

Once the door frame has been placed and secured, continue adding necessary sidewall ring(s). To the lower edge of the bottom ring, attach the base angle ring. Before lowering the bin, apply mastic sealer to the entire underneath side of the base angle. (See below.) Next, lower the bin onto the foundation and check for an adequate seal.



BASE STIFFENER SHIM

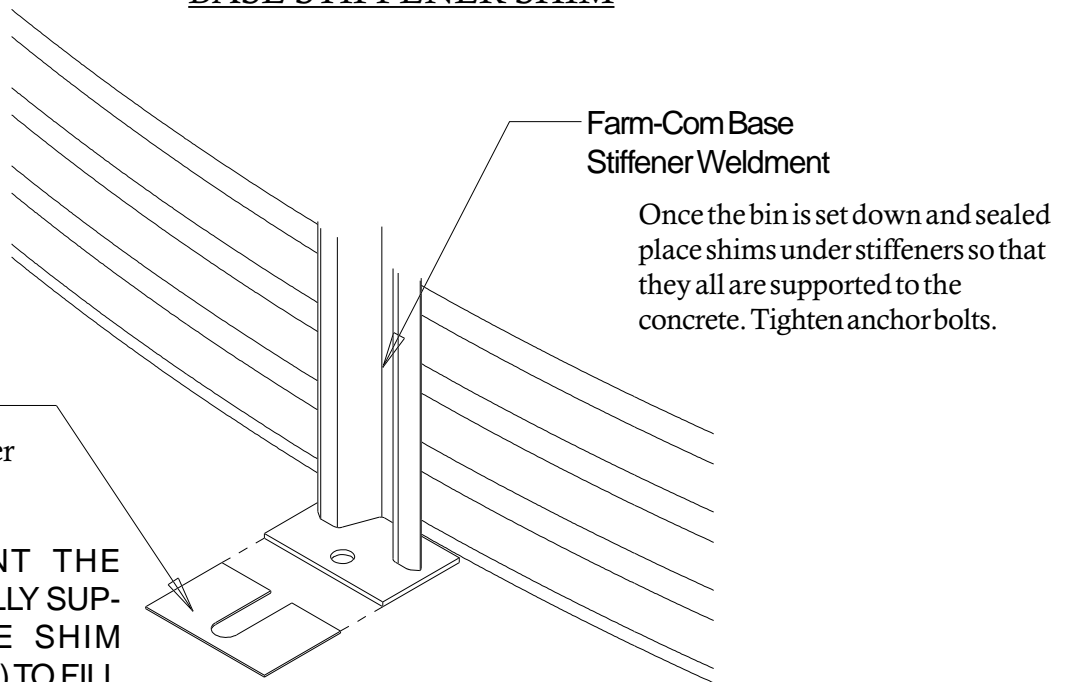

IT IS IMPORTANT THE STIFFENER BE FULLY SUPPORTED BY THE SHIM PLATE(S) (FC-42077) TO FILL ANY GAP BETWEEN BASE PLATE AND CONCRETE.

Figure #64

HI-LO THERMOSTAT

The Hi-Lo Thermostat is designed for use with the GSI Top Dry Crop Dryer units. It comes with one (1) thermostat which is adjustable and cycles the heater from high to low flame. the Hi-Lo Thermostat also comes with a thermometer for monitoring the plenum temperature.

Inatallation:

1. Locate mounting position of thermostat as shown in Figure #58. Important: Do not mount the thermostat *between* the fans on a 2-fan system.
2. Use template supplied to cut hole in sidewall.
3. Apply rope caulk to sides and top of plastic housing. Leave bottom open to let moisture escape.
4. Secure housing to sidewall using self-drilling screws supplied. Be careful not to overtighten. Overtightening may cause the housing to crack.
5. This completes installation instructions for the Hi-Lo Thermostat. For operating instructions, see instructions in the Crop Dryer Unit Owner's Manual.

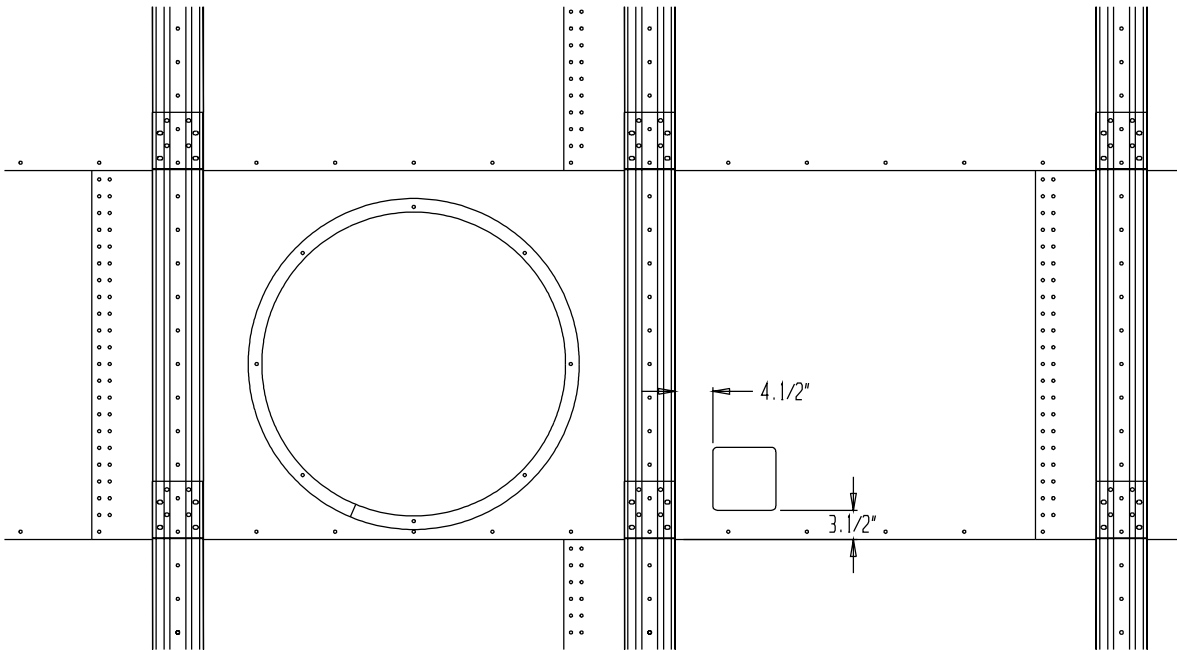

Figure #65