

16" - 36" Platform

Installation Manual

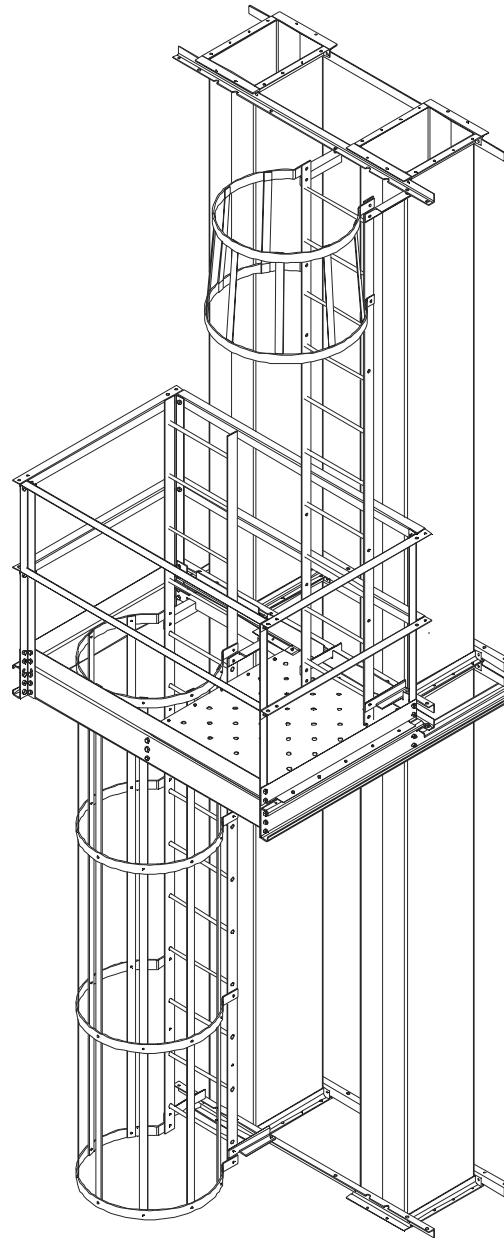

PNEG-1295

Revision Date: 01-09-03



PNEG-1295

Introduction

READ THIS MANUAL carefully to learn how to properly use and install equipment. Failure to do so could result in personal injury or equipment damage.

INSPECT the shipment immediately upon arrival. The Customer is responsible for ensuring that all quantities are correct. Report any damage or shortages by recording a detailed description on the Bill of Lading to justify the Customer's claim from the Transport Firm. Our responsibility for damage to the equipment ends with acceptance by the delivering carrier. Save all paperwork and documentation furnished with any of the equipment.

THIS MANUAL SHOULD BE CONSIDERED a permanent part of your equipment and should be easily accessible when needed.

WARRANTY is provided as part of the company's support program for customers who use and properly maintain their equipment. The warranty is explained on the warranty page located on the inside back cover of this manual.

This warranty provides you the assurance that the company will back its products where defects appear within the warranty period. In some circumstances, the company also provides field improvements, often without charge to the customer, even if the product is out of warranty. Should the equipment be abused, or modified to change its performance beyond the factory specifications, the warranty will become void and field improvements may be denied.

Use of the Equipment Information page will help you identify your equipment in the case that you need to call your dealer or installer. This information should be filled out and kept on record.

Equipment Information

Model Number: _____

Date Purchased: _____

Serial Number: _____

Dealer/Distributor Name and Phone Number:

Material Handling

1004 East Illinois Street
Assumption, Illinois 62510 USA
Phone: (217) 226-4421
FAX: (888) 741-3004
e-mail: gsi@grainsystems.com

Table of Contents

Introduction	3
Equipment Information	4
Safety Guidelines	6
Safety Decal Locations	9
16" - 24" Platform Assembly	
Head Service Platform	10
Floor Sections	11
Toeboards	12
Handrail Posts	13
Access Door	14
Handrails	15
30" - 36" Platform Assembly	
Platform Support Channel	16
Floor Sections	17
Toeboards	18
Vertical Posts	19
Access Door	20
Handrails	21
Ladder Assembly	
Tie Angle Attachments	22
Tie Angle & Cross Braces	23
Ladder Stand Off	24
Ladder Attachment	25
Safety Cage Hoop	26
Safety Cage Vertical Bar	27
Safety Cage Flare	28
Rest Platform	
Side Mounting Channels	30
Platform Corner Posts	31
Front & Rear Mounting Channels	32
Center Support Channel	33
Knee Braces	34
Deck Plate	35
Top & Mid Handrails	36
Kickplates	37
14' Ladder Assembly at Rest Platform	38
4' x 5' Distributor Platform	
Platform Clamps	39
Support Channels & Knee Braces	40
Platform Deck	41
Vertical Posts	42
Handrails	43
6' x 6' Distributor Platform	
Platform Clamps	44
Support Channels & Knee Braces	45
Toeboards	46
Platform Decking	47
Handrails	48
Knee Crossbraces	49

All information, illustrations, photos, and specifications in this manual are based on the latest information available at the time of publication. The right is reserved to make changes at any time without notice.

SAFETY GUIDELINES

This manual contains information that is important for you, the owner/operator, to know and understand. This information relates to protecting **personal safety** and **preventing equipment problems**. It is the responsibility of the owner/operator to inform anyone operating or working in the area of this equipment of these safety guidelines. To help you recognize this information, we use the symbols that are defined below.

Please read the manual and pay attention to these sections. Failure to read this manual and it's safety instructions is a misuse of the equipment and may lead to serious injury or death.



This is the safety alert symbol. It is used to alert you to potential personal injury hazards. Obey all safety messages that follow this symbol to avoid possible injury or death.



DANGER indicates an imminently hazardous situation which, if not avoided, will result in death or serious injury.



WARNING indicates a potentially hazardous situation which, if not avoided, could result in death or serious injury.



CAUTION indicates a potentially hazardous situation which, if not avoided, may result in minor or moderate injury.



CAUTION used without the safety alert symbol indicates a potentially hazardous situation which, if not avoided, may result in property damage.



NOTE indicates information about the equipment that you should pay special attention to.

FOLLOW SAFETY INSTRUCTIONS

Carefully read all safety messages in this manual and on your machine safety signs. Keep signs in good condition. Replace missing or damaged safety signs. Be sure new equipment components and repair parts include the current safety signs. Replacement safety signs are available from the manufacturer.

Learn how to operate the machine and how to use controls properly. Do not let anyone operate without instruction.

Keep your machinery in proper working condition. Unauthorized modifications to the machine may impair the function and/or safety and affect machine life. All service accessories are intended for the proper use in which they were designed. Any misuse of the equipment or accessories will void the warranty. Misuse can cause failure, severe injury or death to the user. The manufacturer cannot be responsible for the erection or use of the bucket elevator and it's accessories.

If you do not understand any part of this manual and need assistance, contact your dealer.

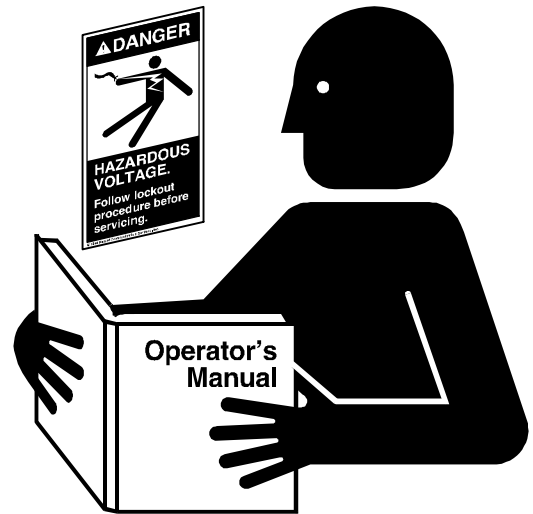

PRACTICE SAFE MAINTENANCE

Understand service procedures before doing work. Keep area clean and dry.

Never lubricate, service, or adjust machine while it is in operation. Keep hands, feet, and clothing from rotating belt and idlers.

Keep all parts in good condition and properly installed. Fix damage immediately. Replace worn or broken parts. Remove any build up grease, oil, or debris.



PREPARE FOR EMERGENCIES

Be prepared if fire starts.

Keep a first aid kit and fire extinguisher handy.

Keep emergency numbers for doctors, ambulance service, hospital, and fire department near your telephone.

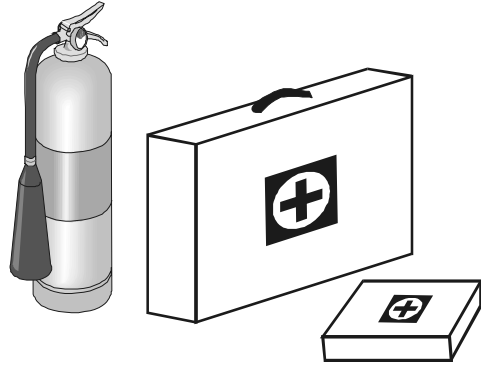

WEAR PROTECTIVE CLOTHING

Wear close fitting clothing and safety equipment appropriate to the job.

Safety glasses should be worn at all times to protect eyes from debris.

Wear gloves to protect your hands from sharp edges on plastic or steel parts.

A respirator may be needed to help prevent breathing potentially toxic fumes and dust.

Wear hard hat and steel toe boots to help protect your head and toes from falling debris.

Eye Protection

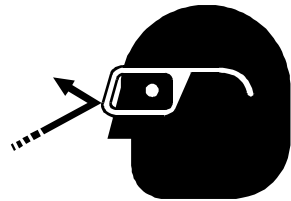

Gloves



Steel Toe Boots



Respirator



Hard Hat



DECAL LOCATIONS

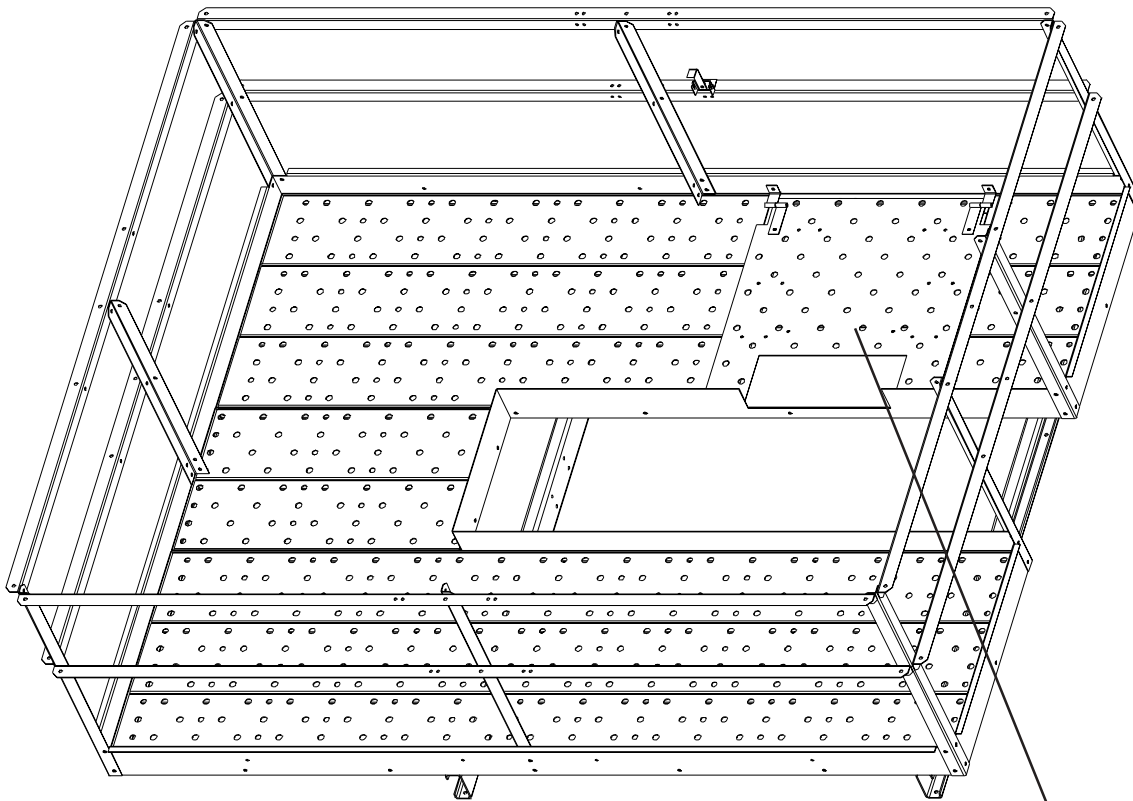

Decal located on bottom of platform access door.

	<p>! DANGER</p> <p>FALL HAZARD Serious injury or death will result. Keep access door closed while on platform.</p> <p>DC-1568</p>
--	--

DC-1568

Head Service Platform

When laying out the ladder, safety cage, and platforms be sure to always start from the head service platform and work your way down the leg. Keep in mind a rest platform needs to be located at every 30' of vertical descent to comply with OSHA Standards.

Take time now and review all instructions and drawings before attempting to assemble the

platforms. Layout all parts for easy identification. Determine if your equipment is left or right hand shaft. The support channels will mount in the same location for right hand or left hand drive setup. The support channels will extend same distance on each side of the head. Start the **head service platform** assembly by attaching two support channels to the head platform clips. Use 3/8" x 1" bolts and whiz nuts. (See Figure 1.)

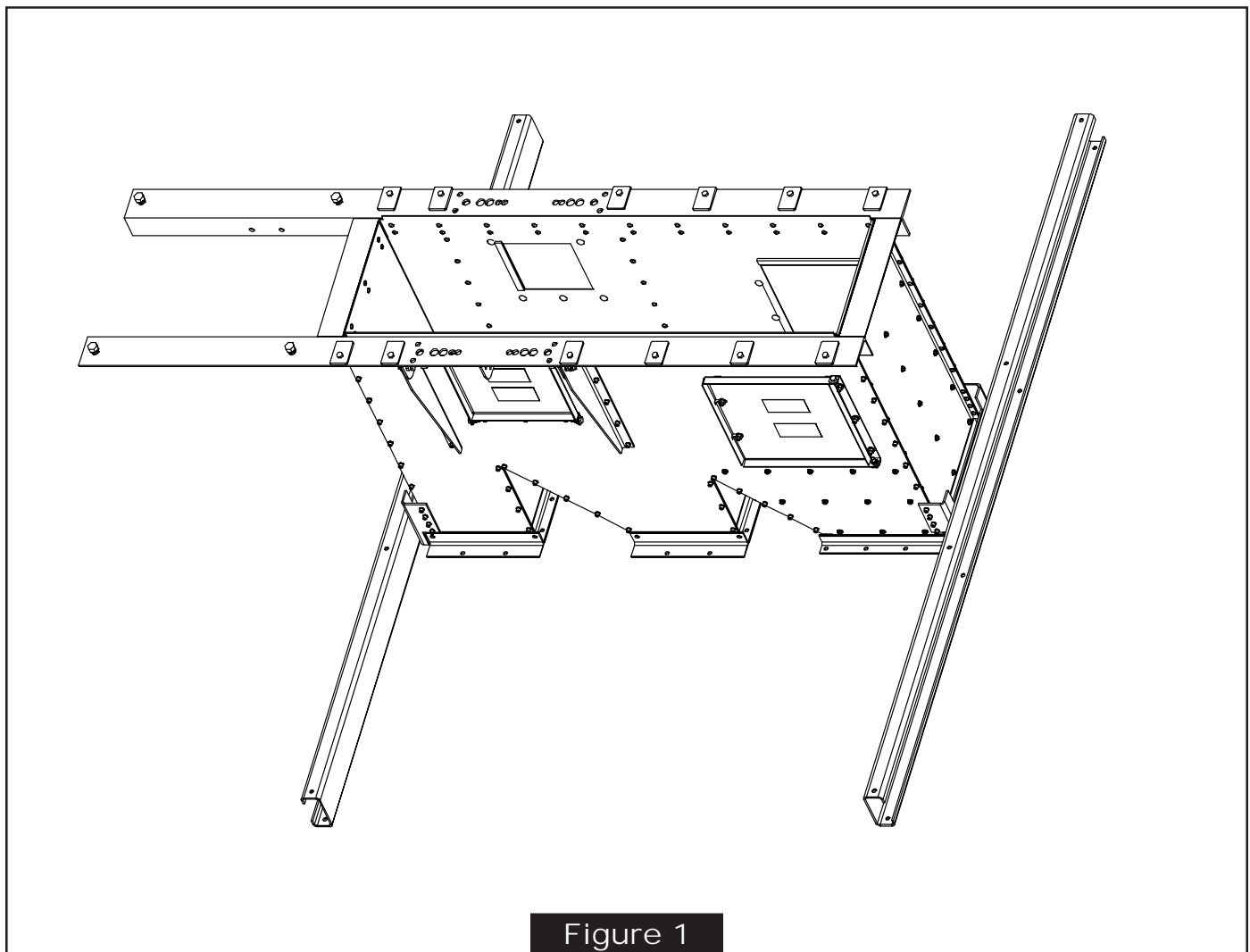
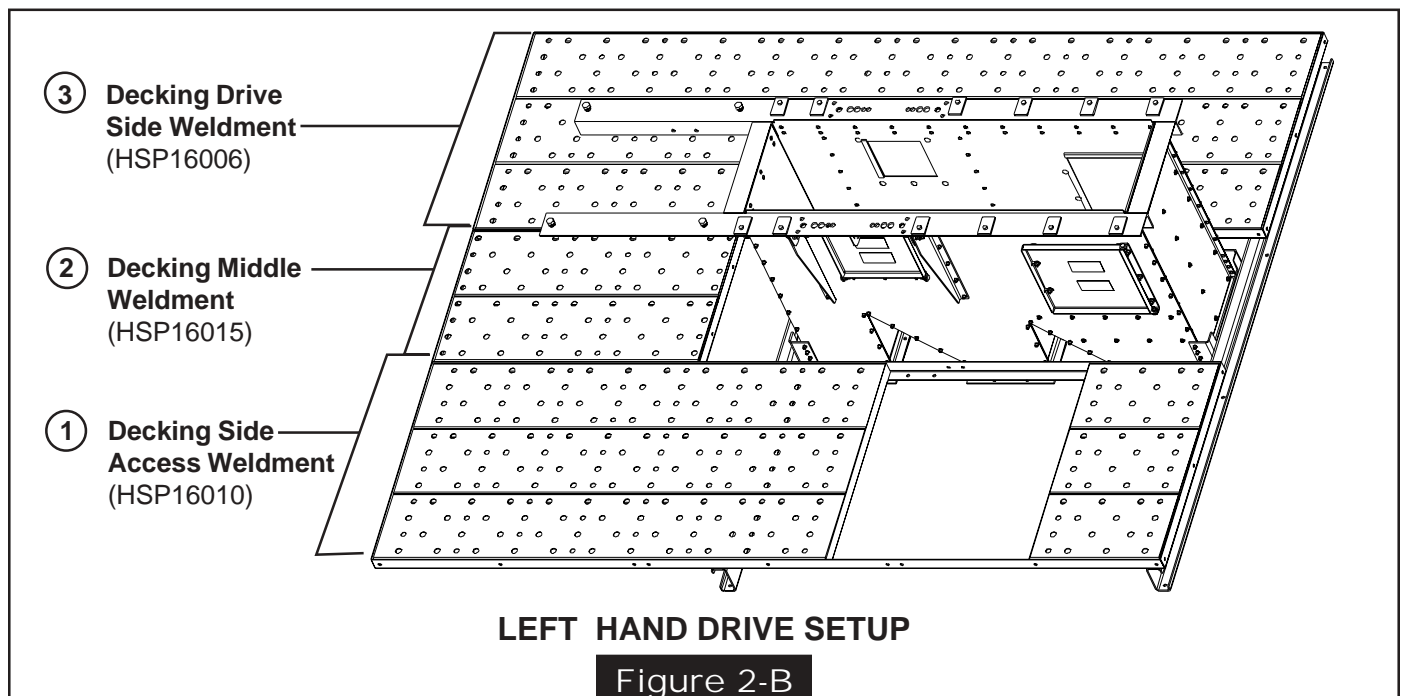
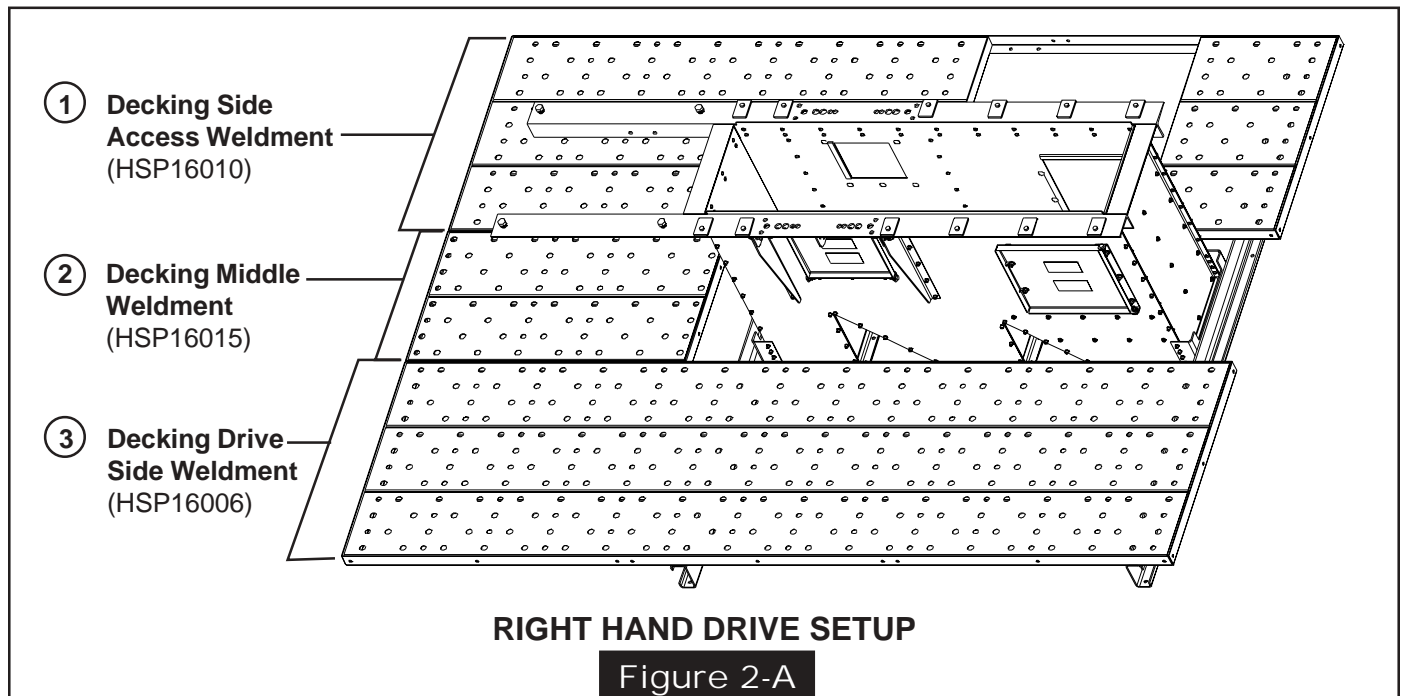

Figure 1

Floor Sections

Place outside floor sections (#1 & #3) on support channels in location shown below and fasten using 3/8" x 1" bolts and whiz nuts, for right hand drive see Fig. 2-A, for left hand drive

see Fig. 2-B. Fasten middle floor section to the two outside floor sections with 3/8" x 1" bolts and whiz nuts. Make sure not to tighten the hardware until assembly is complete.



Toeboards

Fasten toeboards to floor sections in the position shown in Fig. 3-A for right hand drive, and Fig. 3-B for left hand drive, using 3/8" x 1" bolts and whiz nuts. Leave hardware out of

end holes in toeboards, the vertical posts will mount in these holes. Make sure not to tighten hardware until assembly is complete.

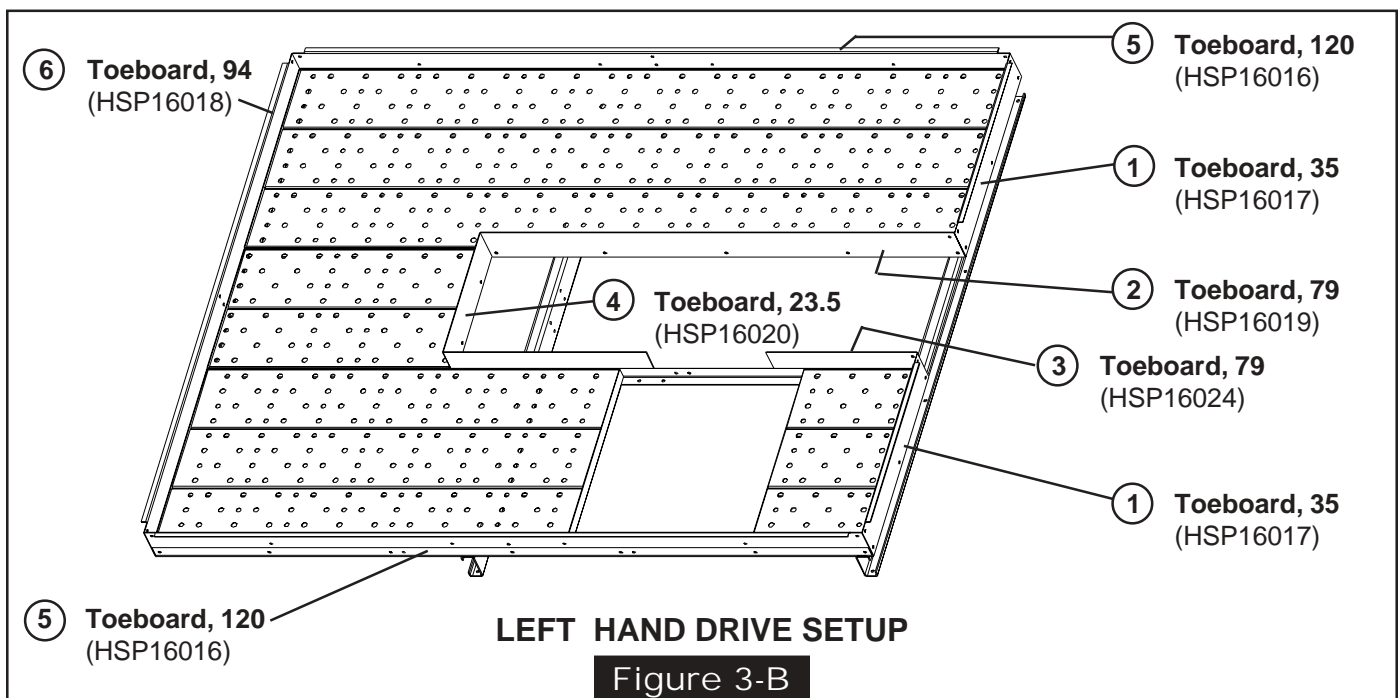
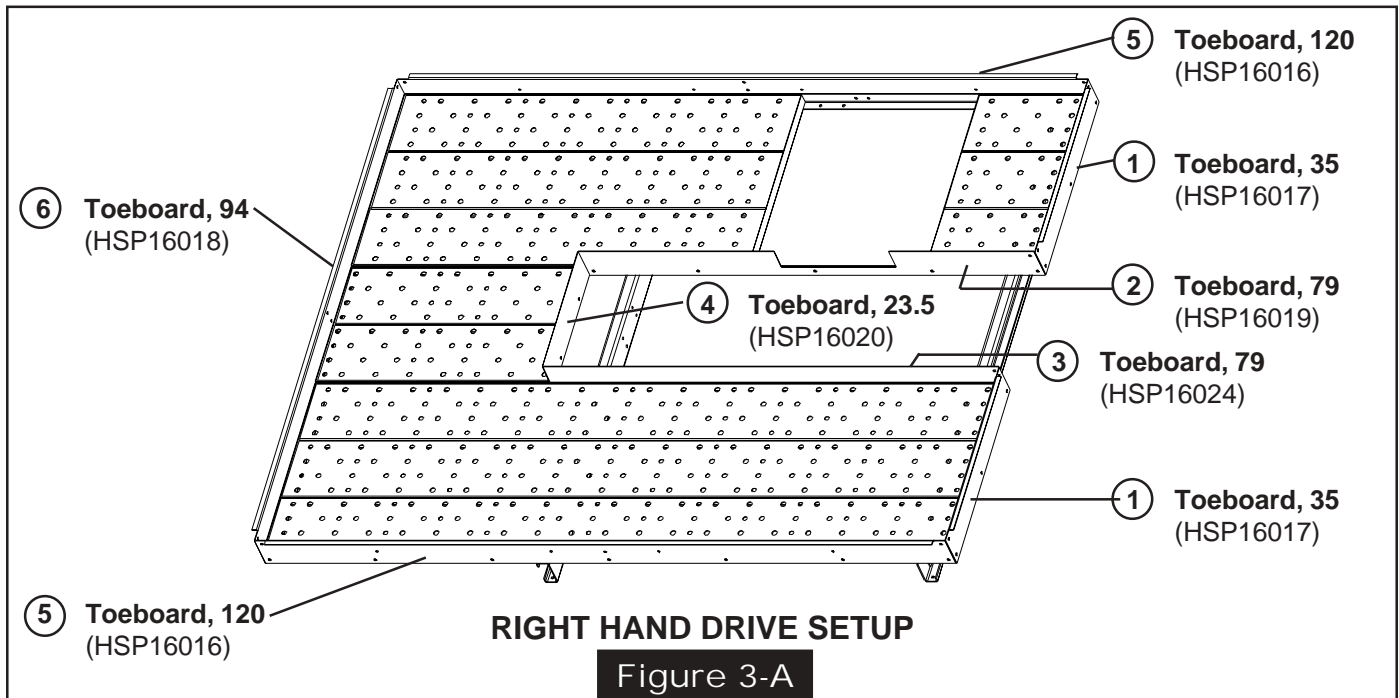

Handrail Posts

Place vertical posts in position as shown in Figures 4-A & 4-B. Fasten with 3/8" x 1" bolts and whiz nuts. Make sure not to tighten hardware until assembly is complete. The three

middle posts sit on top of floor section on inside of the toeboards. All the other angles fit on the outside of the toeboards flush with the bottom of the toeboards. See figures below.

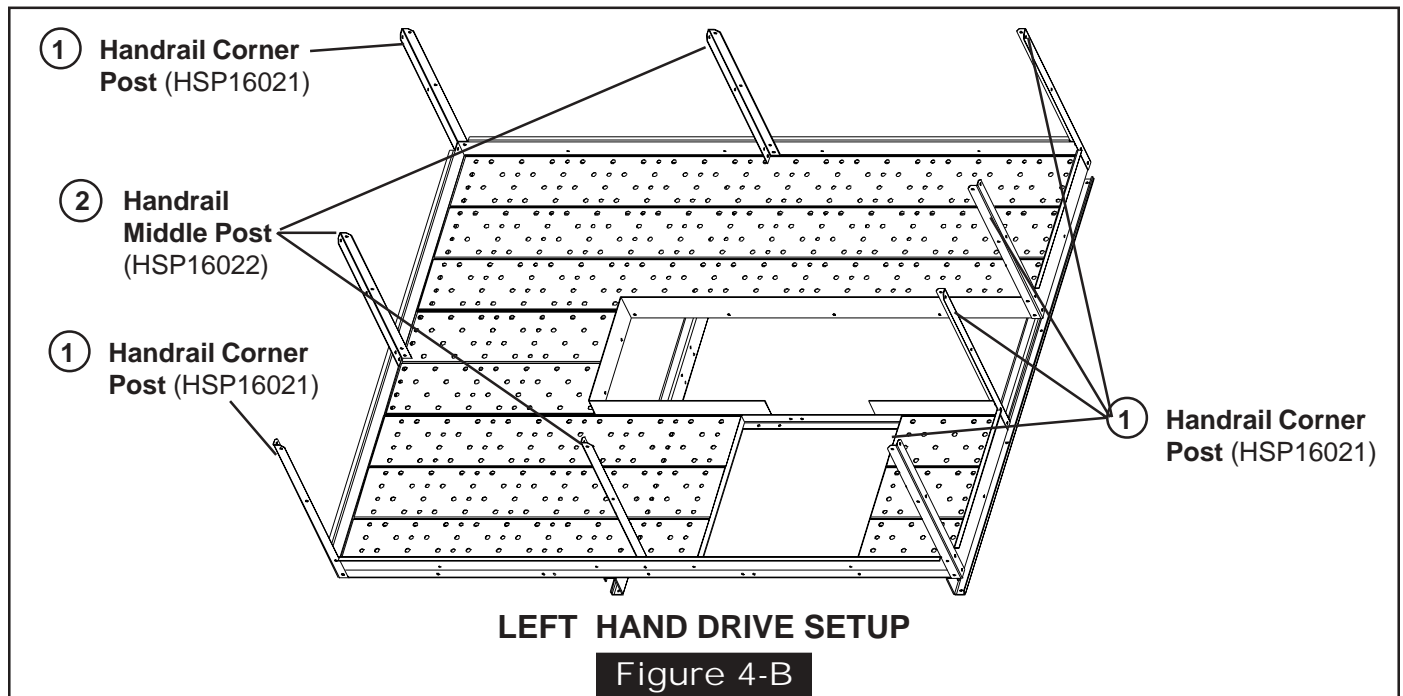
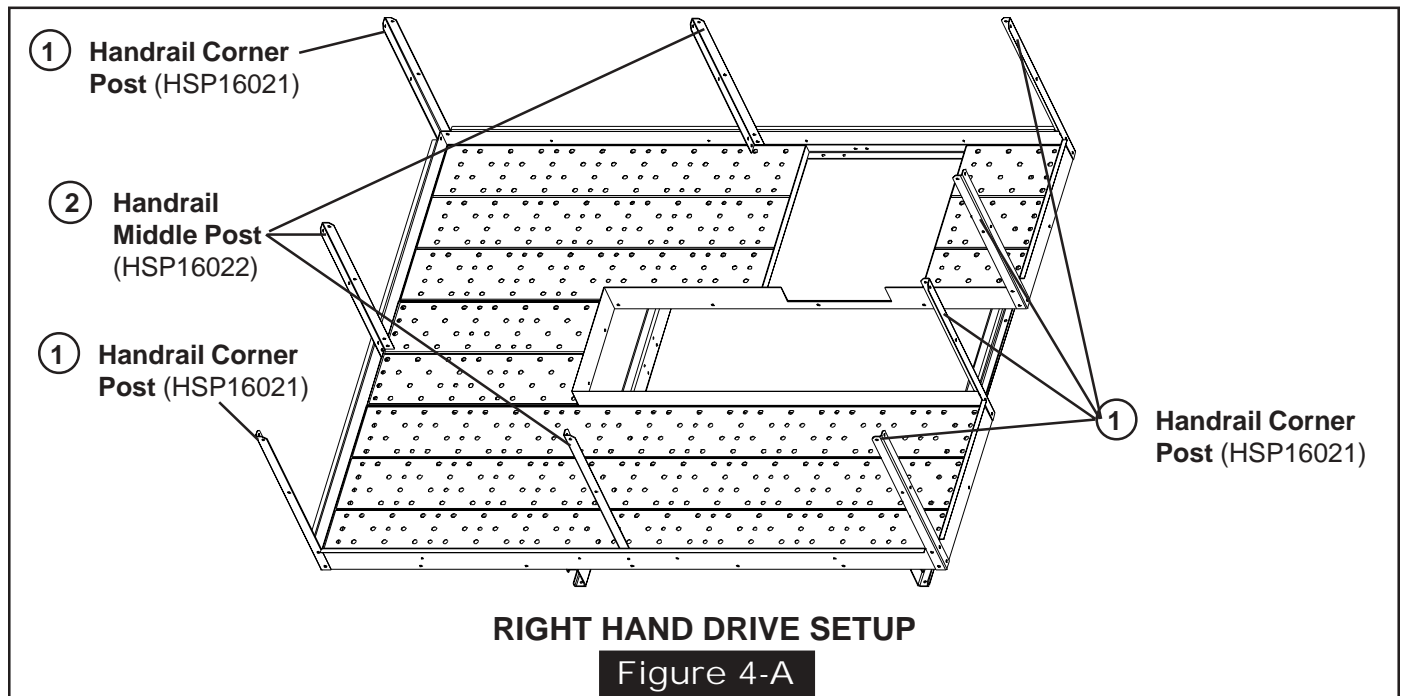

Access Door

Attach the access door hinges angles to the toeboards using 5/16" x 1" bolts and whiz nuts. Next attach the access door hinge leaves to the deck hatch assembly using 5/16" x 1" bolts and whiz nuts. Leave hardware loose until position-

ing the deck hatch assembly into position. Insert 5/16" x 3-1/2" bolt thru both hinge parts and secure with 2 hex nuts on each bolt. Check alignment of all parts and tighten hinge parts to toeboard and deck hatch assembly.

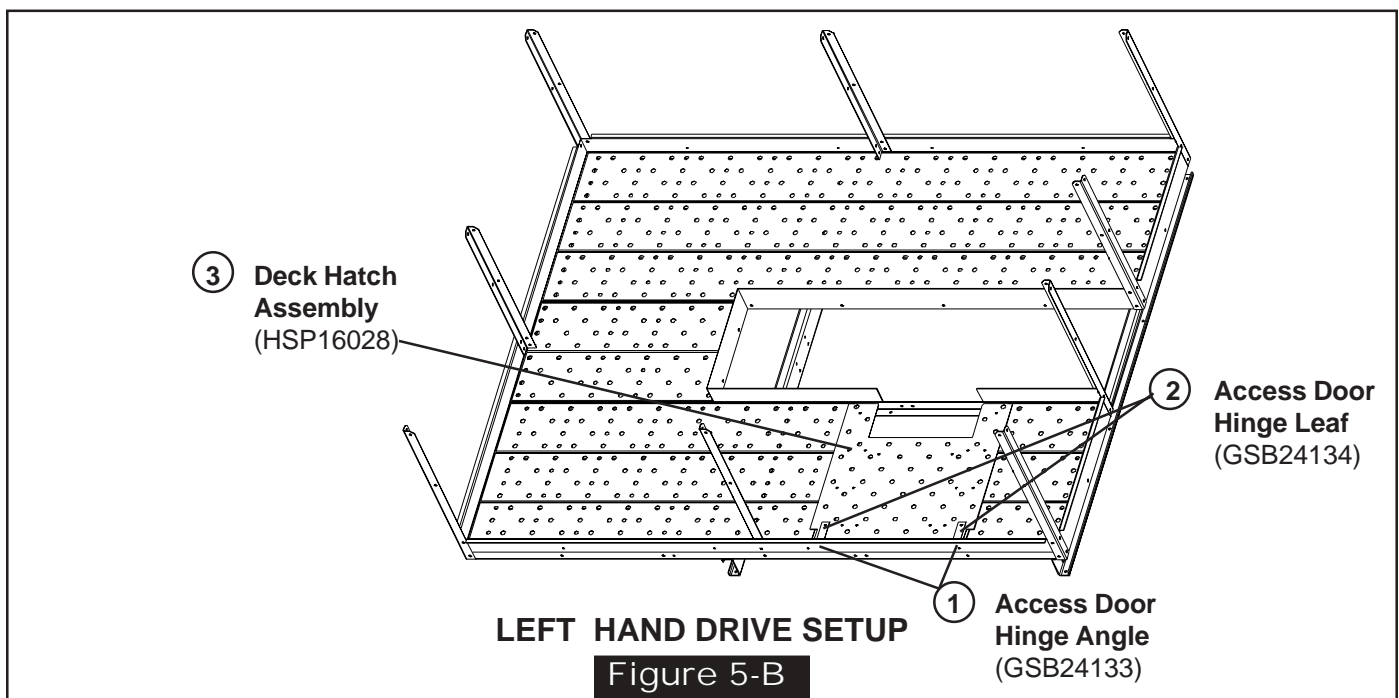
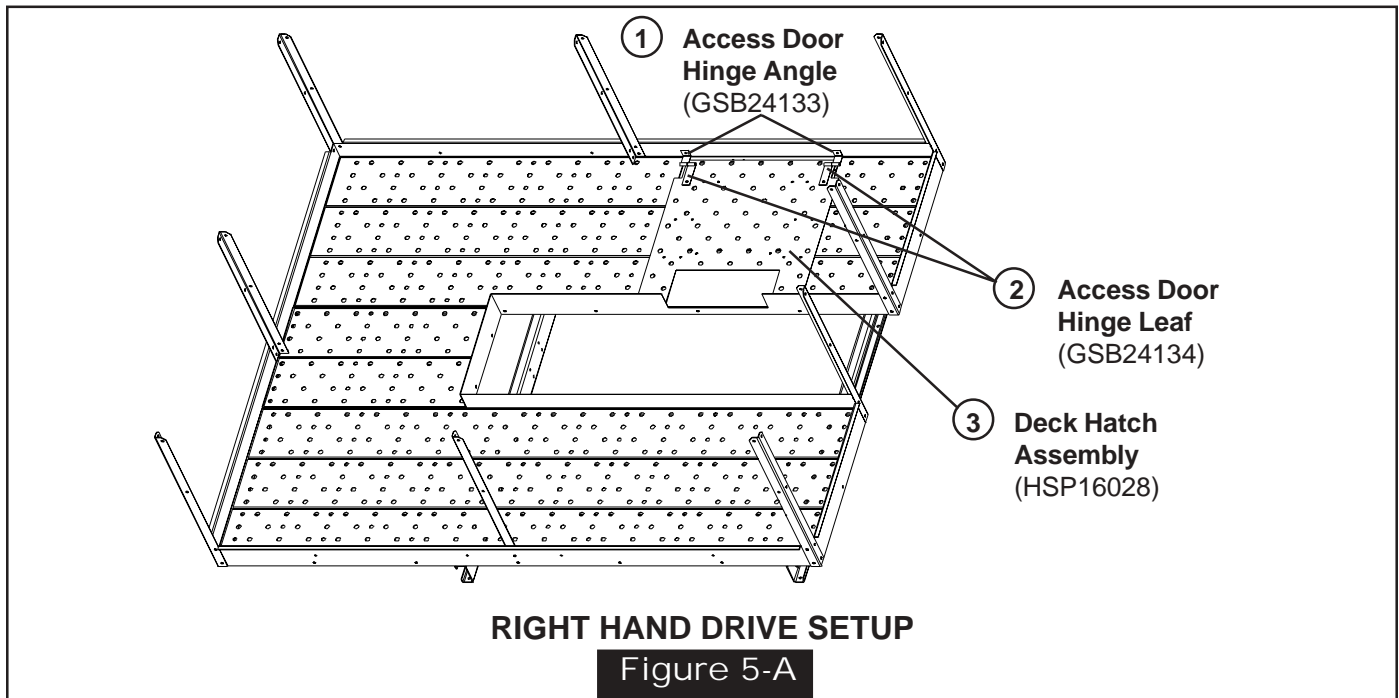

Handrails

Attach handrails to vertical posts in position as shown in Fig. 6-A & 6-B with 3/8" x 1" hardware. Attach latch for deck hatch assembly to

lower handrail next to the center vertical post using 5/16" x 1" hardware. Now go back and tighten all hardware.

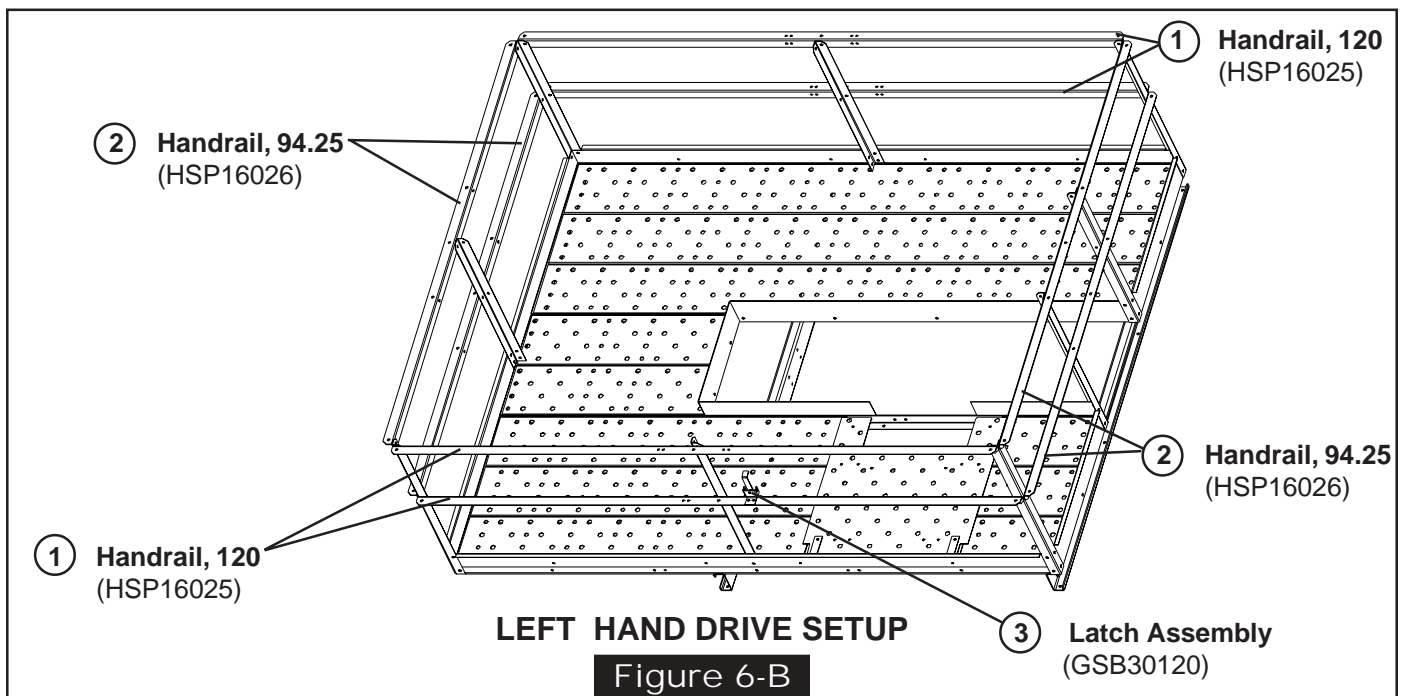
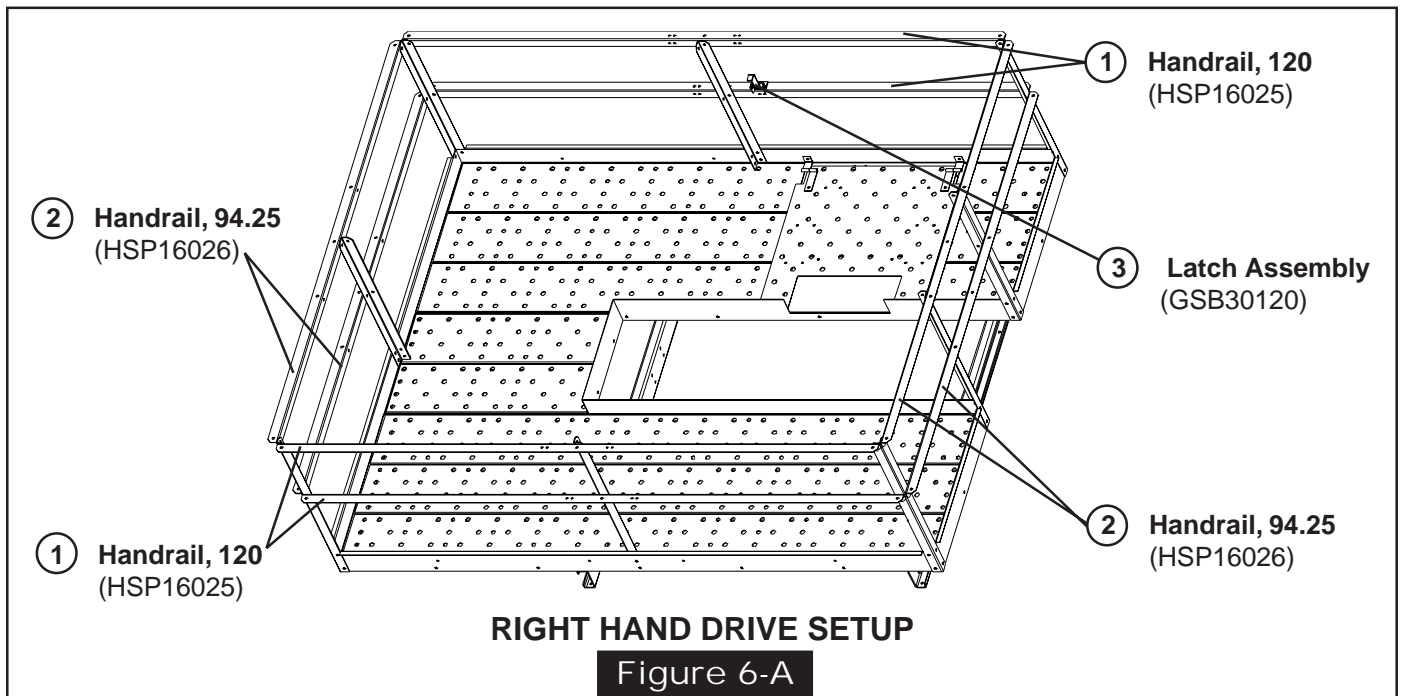

Platform Support Channel

When laying out the ladder, safety cage, and platforms be sure to always start from the head service platform and work your way down the leg. Keep in mind a rest platform needs to be located at every 30' of vertical descent to comply with OSHA Standards. Take time now and review all instructions and drawings before attempting to assemble the platforms. Layout all parts for easy

identification. Determine if your equipment is left or right hand shaft. Once determining that, the long side of the support channels must extend to the shaft side of the head. Start the head service platform assembly by attaching two support channels to the head platform clips with 3/8" x 1" hardware. The third support channel will be attached once floor sections are in place. See Figure below.

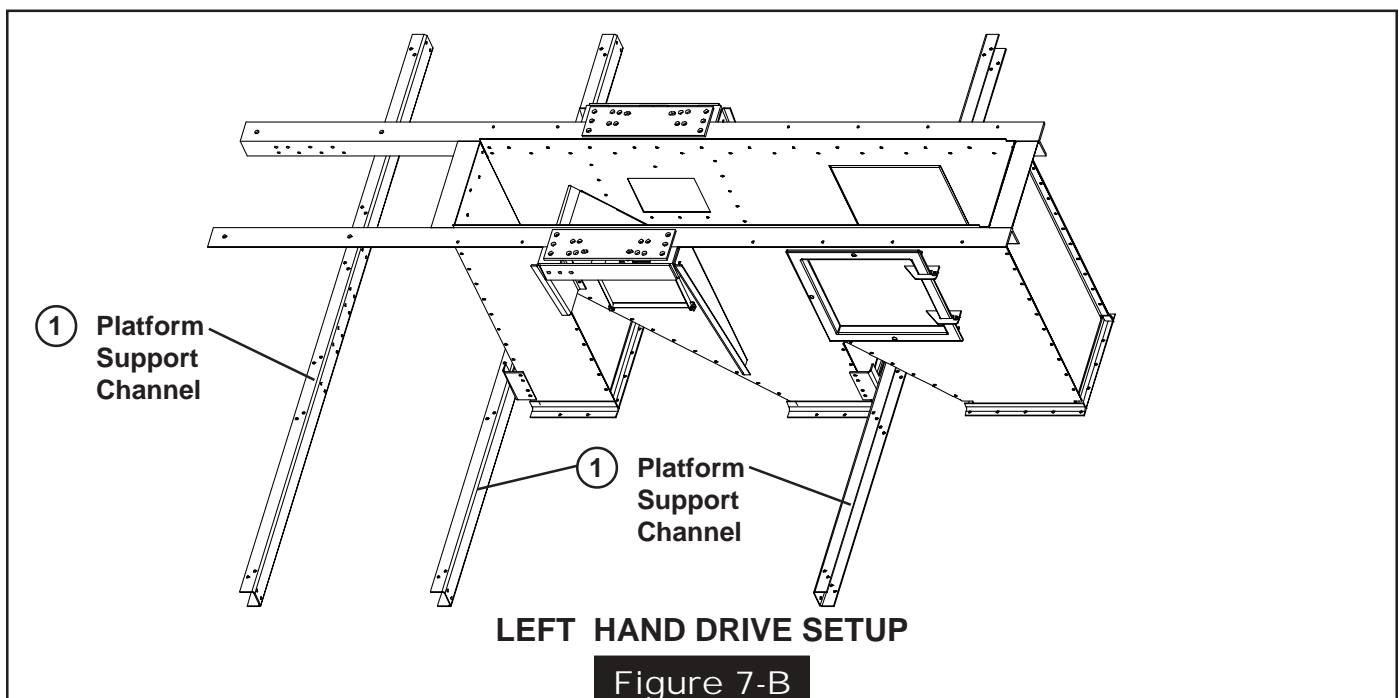
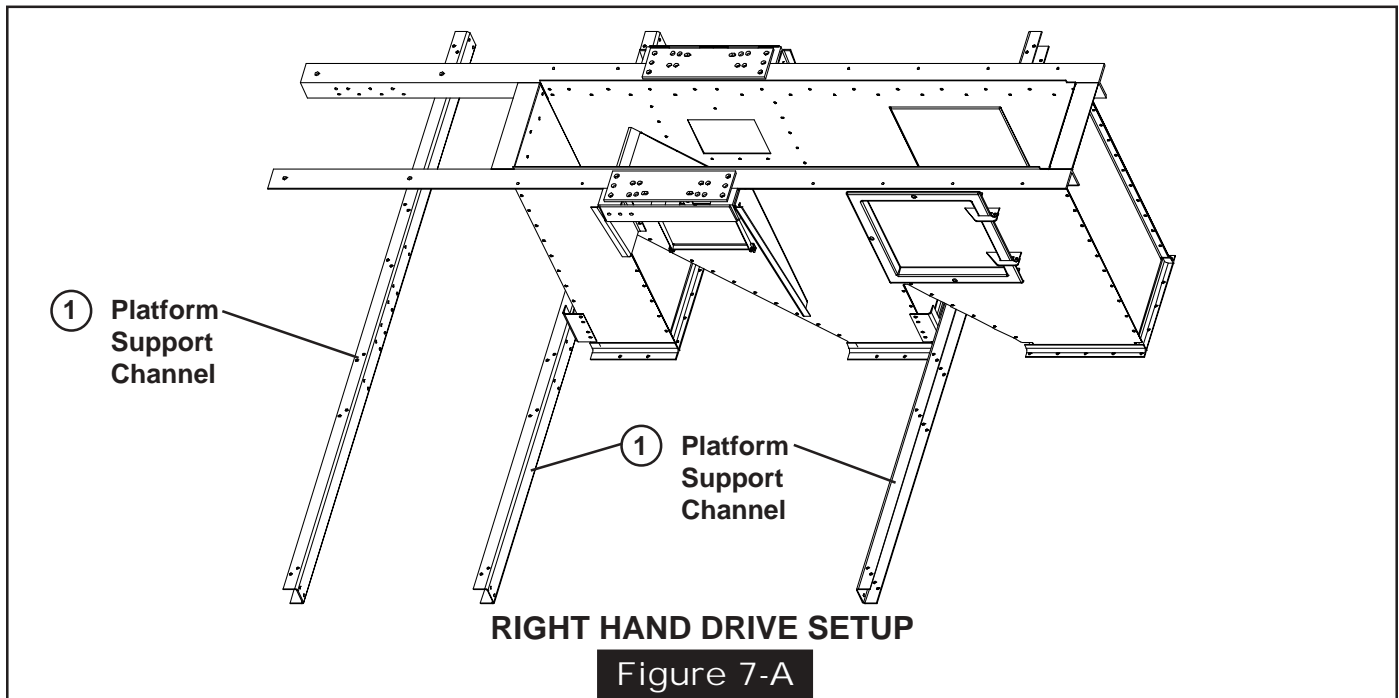

Floor Sections

Fasten decking weldment floor section to the two support channels with 3/8" x 1" bolts and whiz nuts. Attach the two vertical support angles to the rear of the head angles using 1/2" x 1" bolts and nuts. Attach the other end to the support channel using 3/8" x 1" bolts and whiz nuts. Place outside floor sections on

support channels in location shown below and fasten to support channels and decking weldment using 3/8" x 1" bolts and whiz nuts, for right hand drive see Fig. 8-A, for left hand drive see Fig. 8-B. Make sure not to tighten the hardware until assembly is complete.

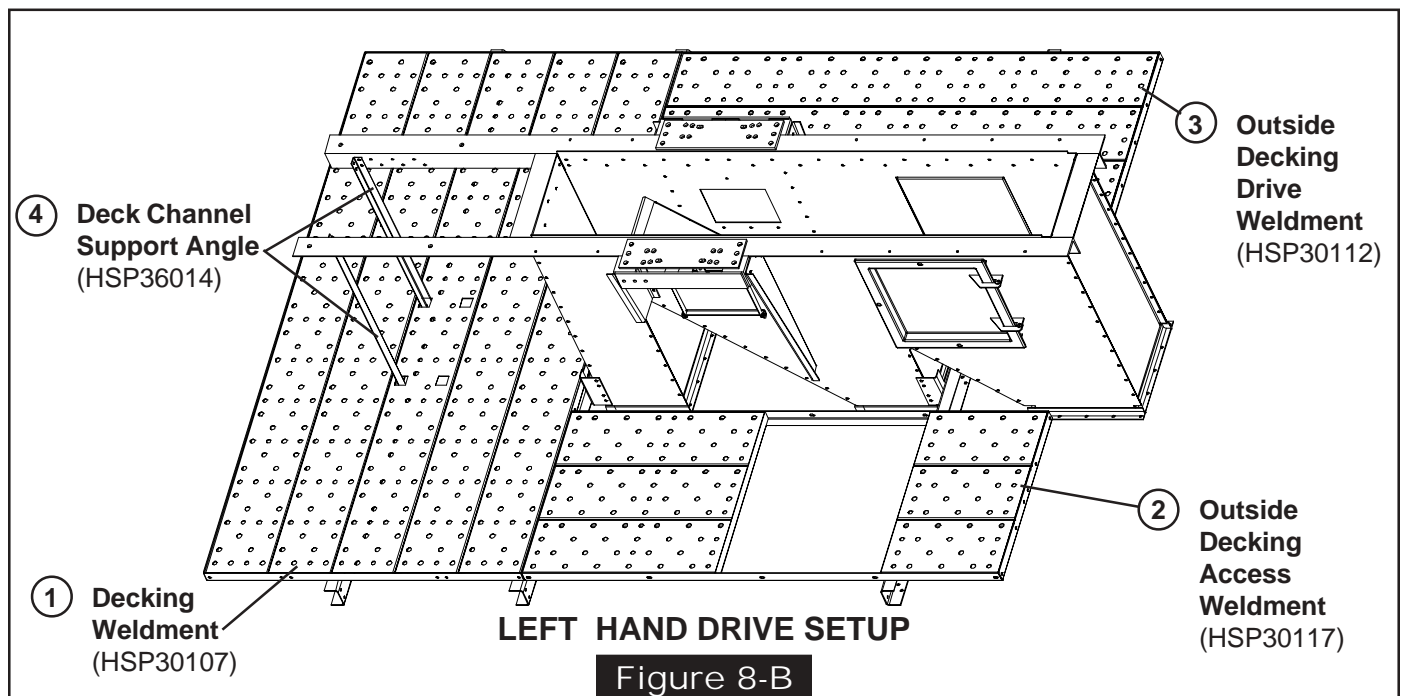
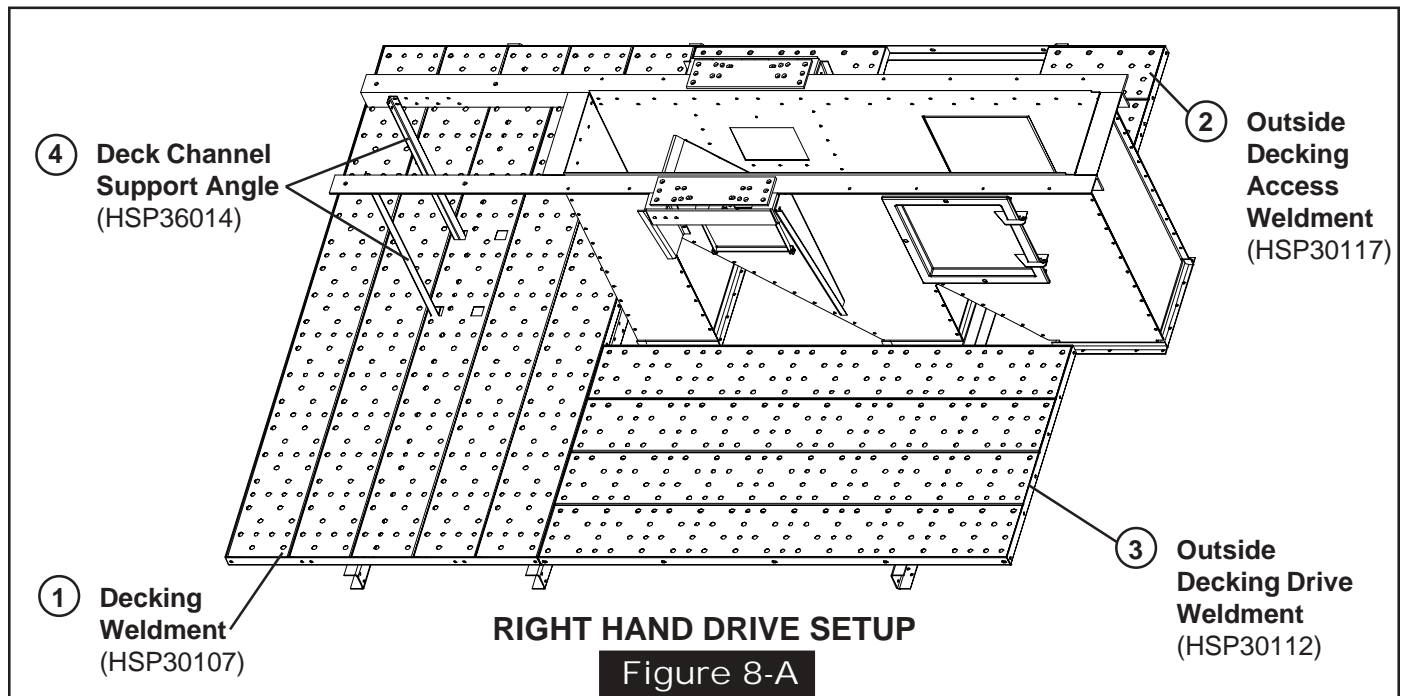

Toeboards

Fasten toeboards to floor sections in the positions as shown in Fig. 9-A for right hand drive, and Fig. 9-B for left hand drive, using 3/8" x 1" bolts and whiz nuts. Make sure not to

tighten hardware until assembly is complete. Leave hardware out of end holes in toeboards and the holes at the support channels, the vertical posts will mount using these holes.

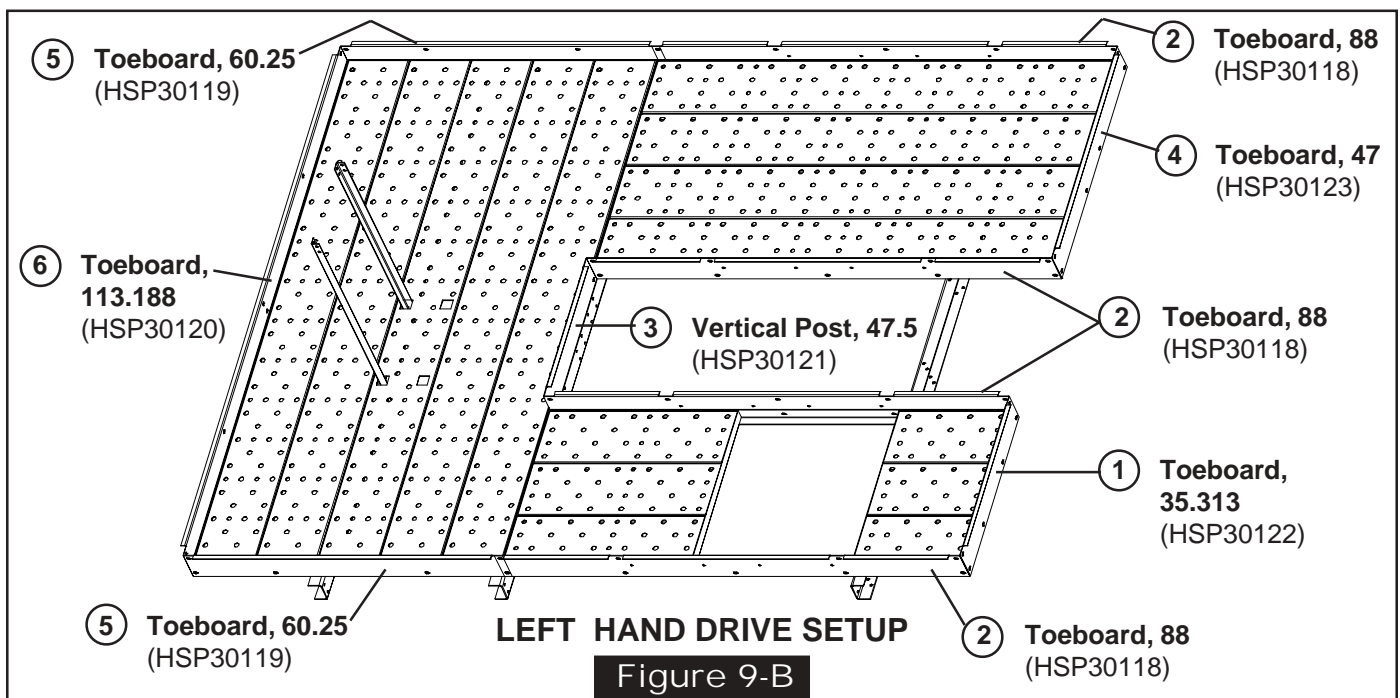
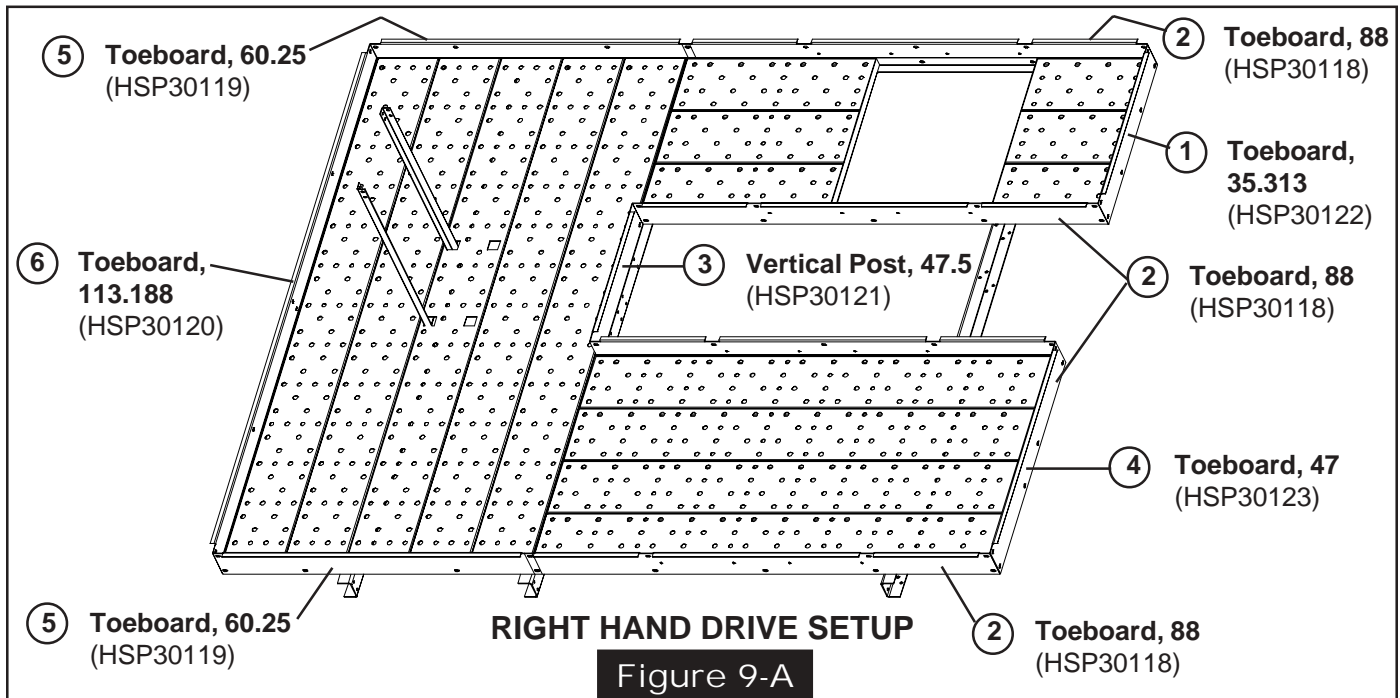

Handrail Post

Place vertical posts in position as shown below in Figures 10-A & 10-B. Fasten with 3/8" x 1" bolts and whiz nuts. Make sure not to tighten hardware until assembly is complete. The angle in the middle on the end sits on top of

floor section on inside of the toeboards. All the other angles fit on the outside of the toeboards and flush with the bottom of the support channels. When complete go back and tighten hardware.

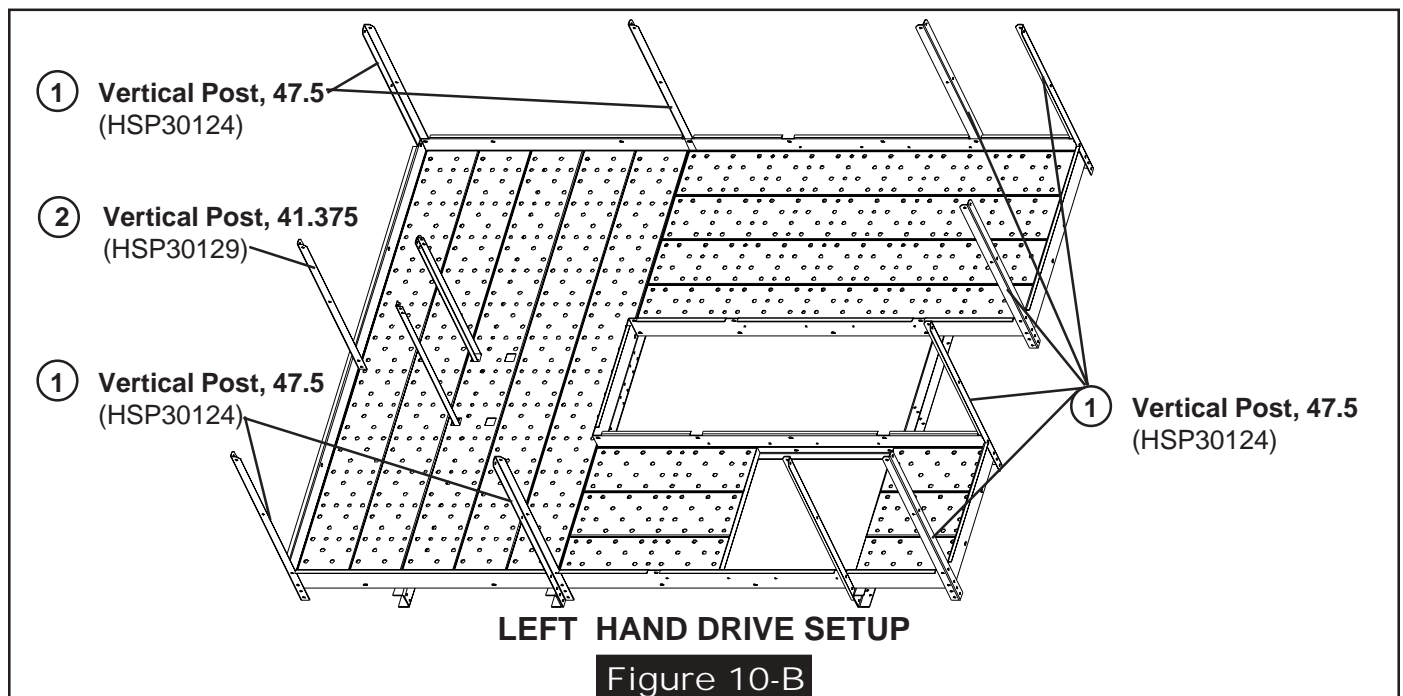
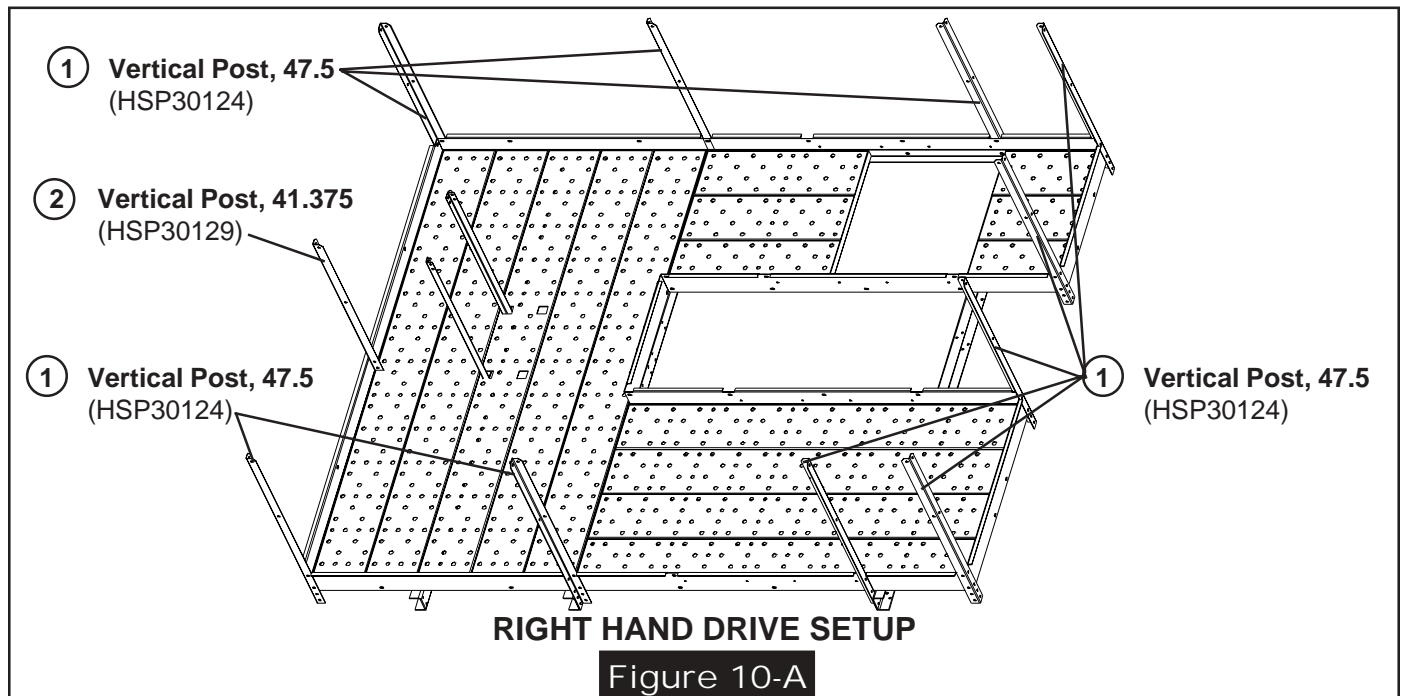

Access Door

Attach the access door hinges angles to the toeboards using 5/16" x 1" bolts and whiz nuts. Next attach the access door hinge leaves to the deck hatch assembly using 5/16" x 1" bolts and whiz nuts. Leave hardware loose until position-

ing the deck hatch assembly into position. Insert 5/16" x 3-1/2" bolt thru both hinge parts and secure with 2 hex nuts on each bolt. Check alignment of all parts and tighten hinge parts to toeboard and deck hatch assembly.

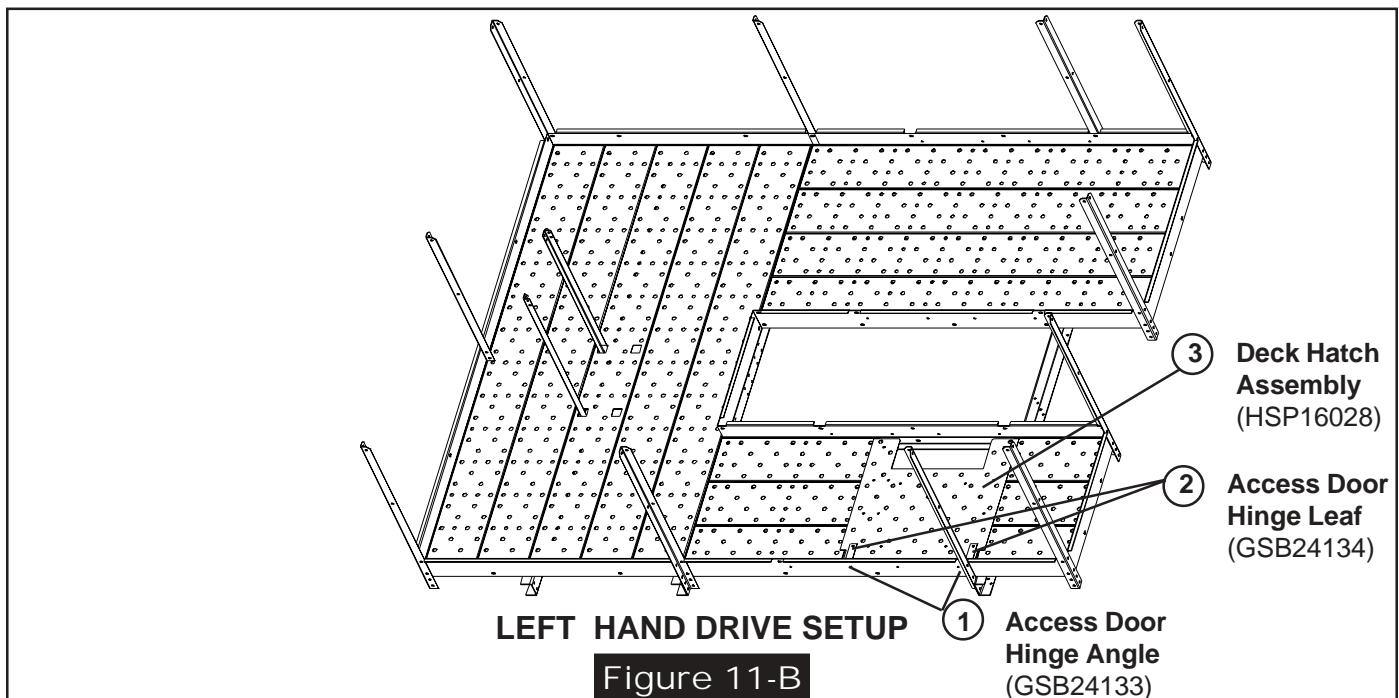
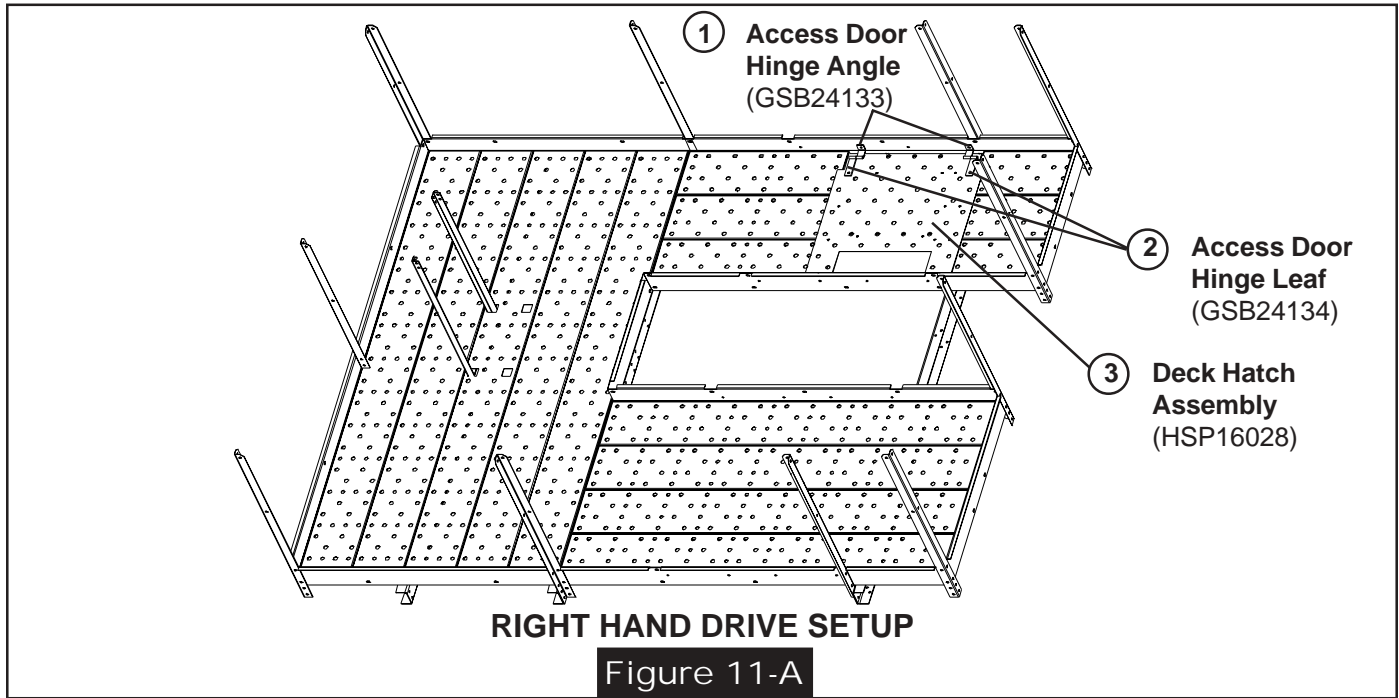

Handrails

Attach handrails to vertical posts in position as shown below with 3/8" x 1" hardware. Attach latch for deck hatch assembly to lower handrail using 5/16" x 1" hardware. Now go back and tighten all hardware.

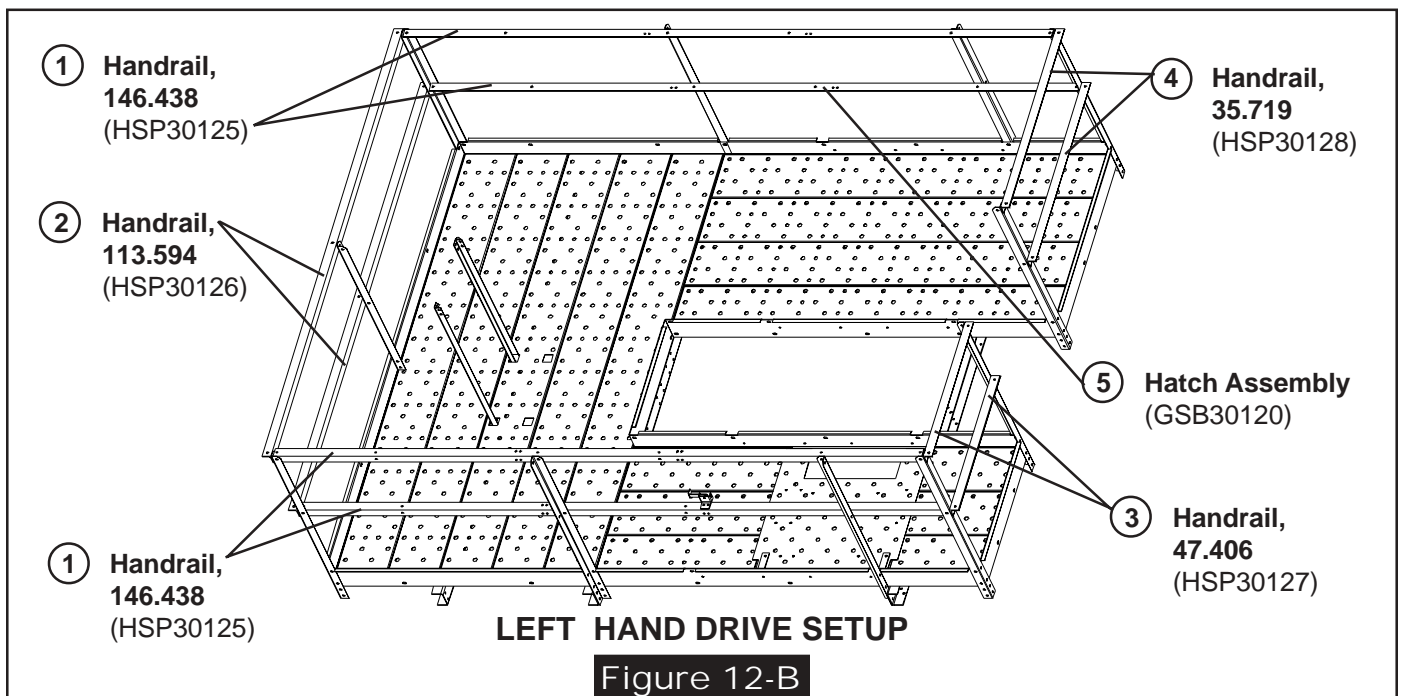
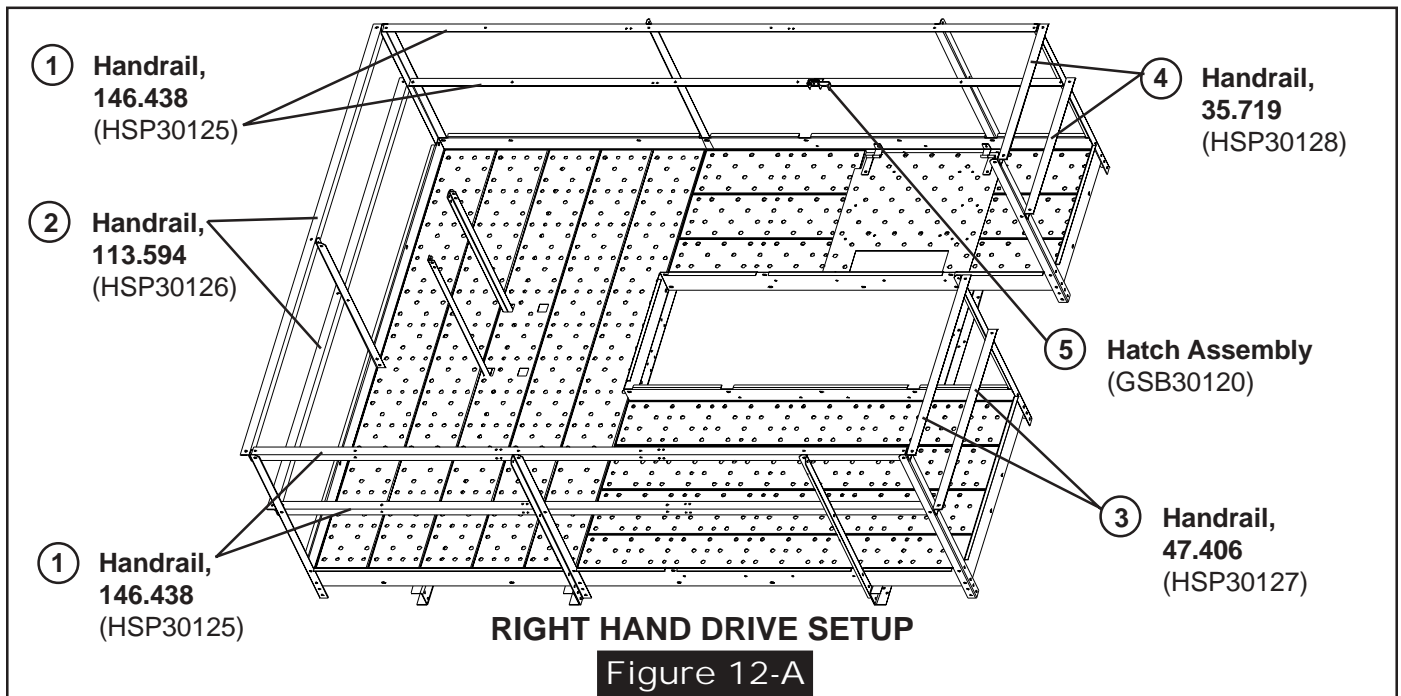

Tie Angle Attachment

Attach the up and down legs together with the tie angles. Position the tie angles as shown and fasten with the 1/2" - 13 x 1" bolts.

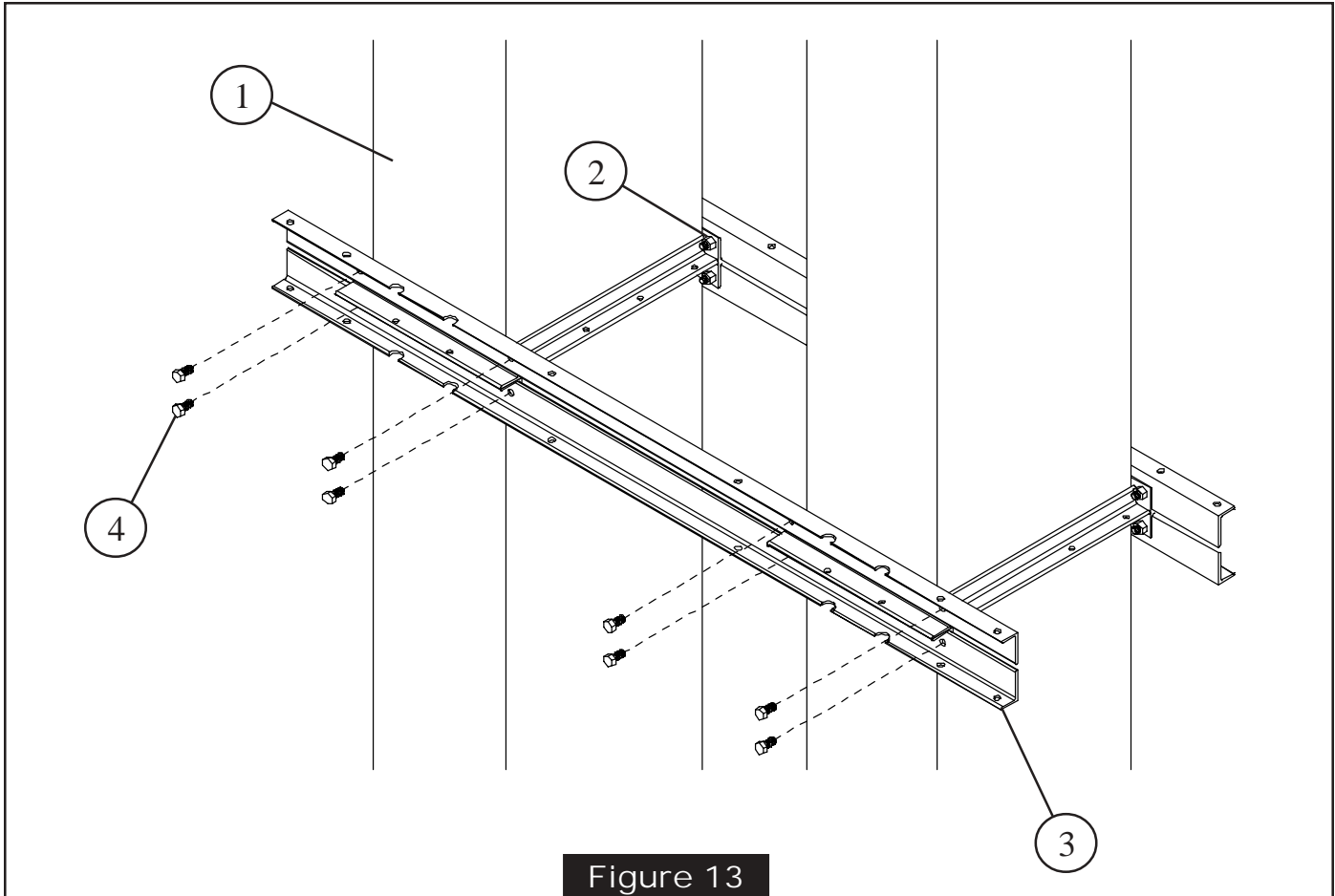
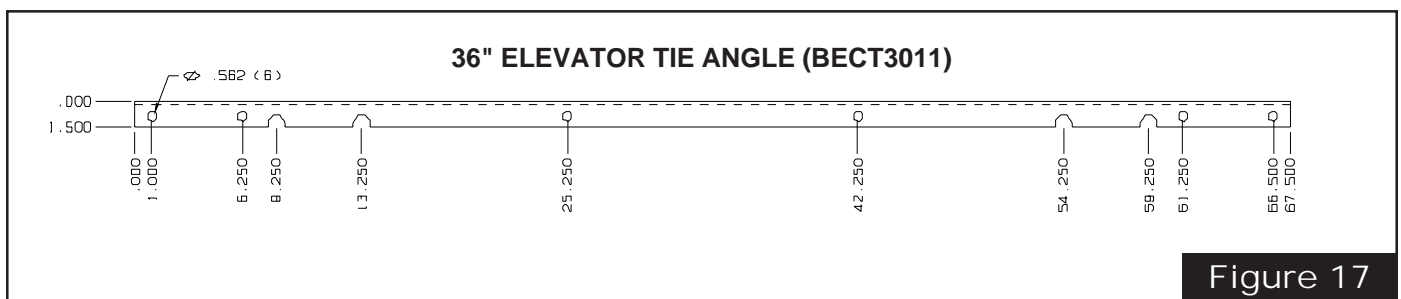
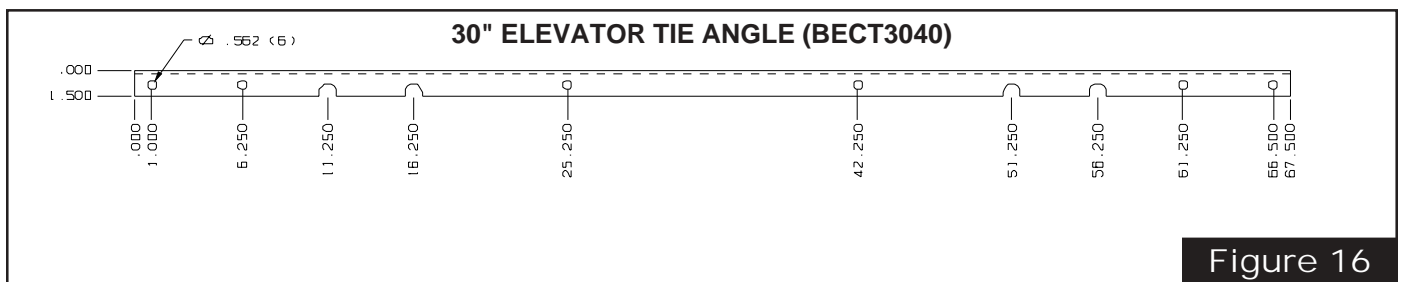
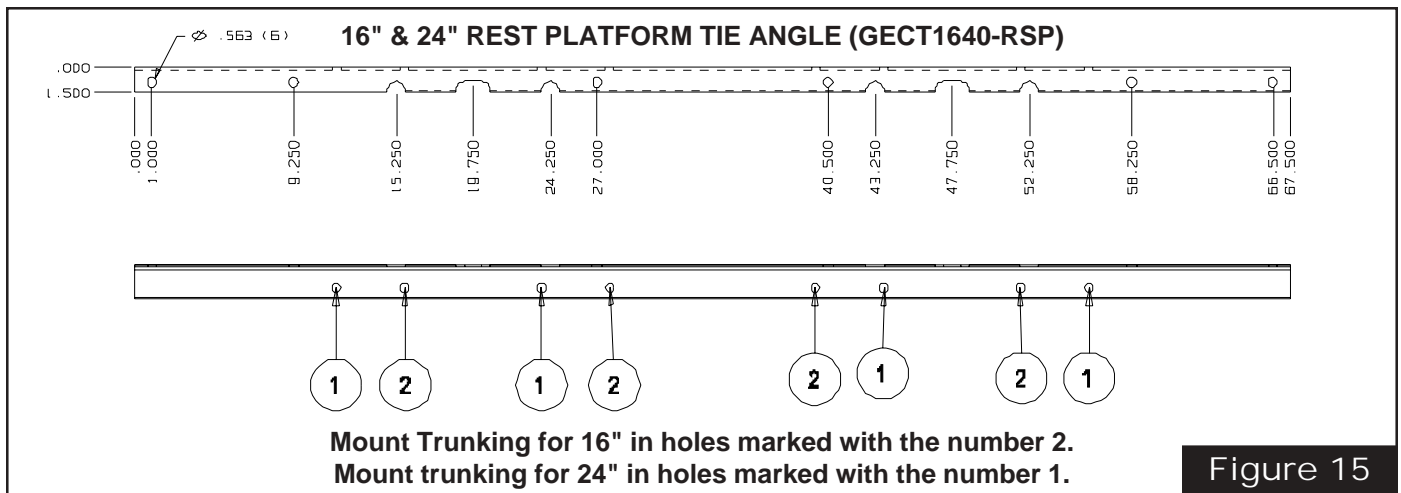
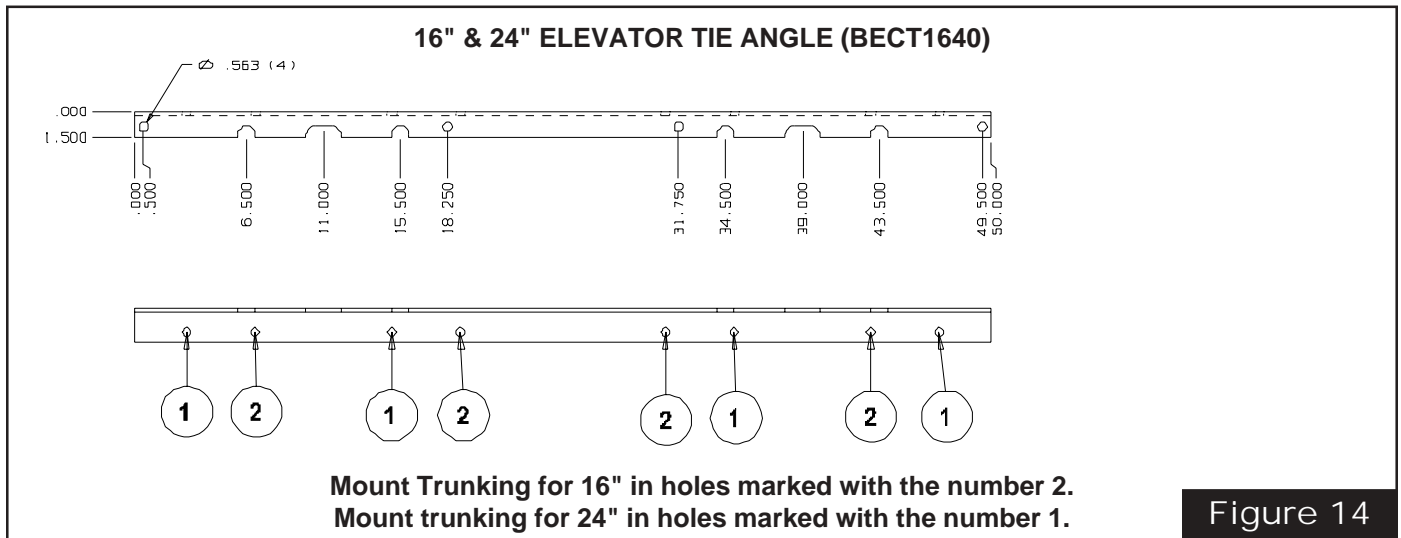

Figure 13

1. Trunking Section
2. 1/2" - 13 Hex Nut
3. Tie Angle
4. 1/2" - 13 x 1" Hex Bolt

Tie Angle and Cross Braces



Ladder Stand Off Bracket

Attach the ladder stand off bracket to the tie angles.

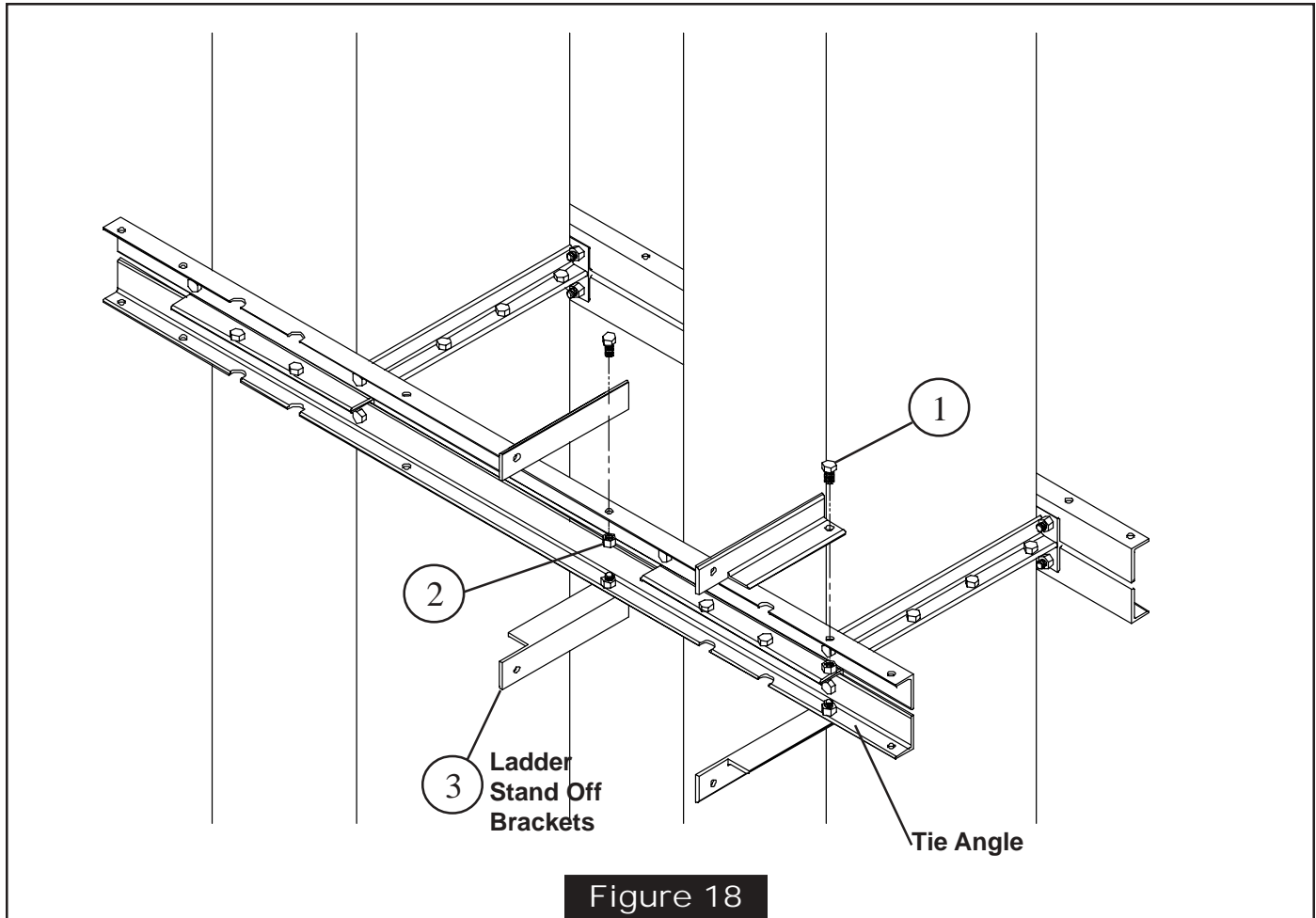

1. 1/2" - 13 x 1" Hex Bolt
2. 1/2" - 13 Hex Nut
3. Ladder Stand Off Bracket
Left- (be-plat1)
Right- (be-plat2)

Ladder Attachment

When attaching the ladder to the standoffs the ladder is attached through the second hole down from the end of the ladder. The first hole is used to attach the safety cage hoop.

On 16" & 24" the stand off angles mount inside ladder. See Fig. On 30" & 36" the stand of Angle mounts to outside of ladder.

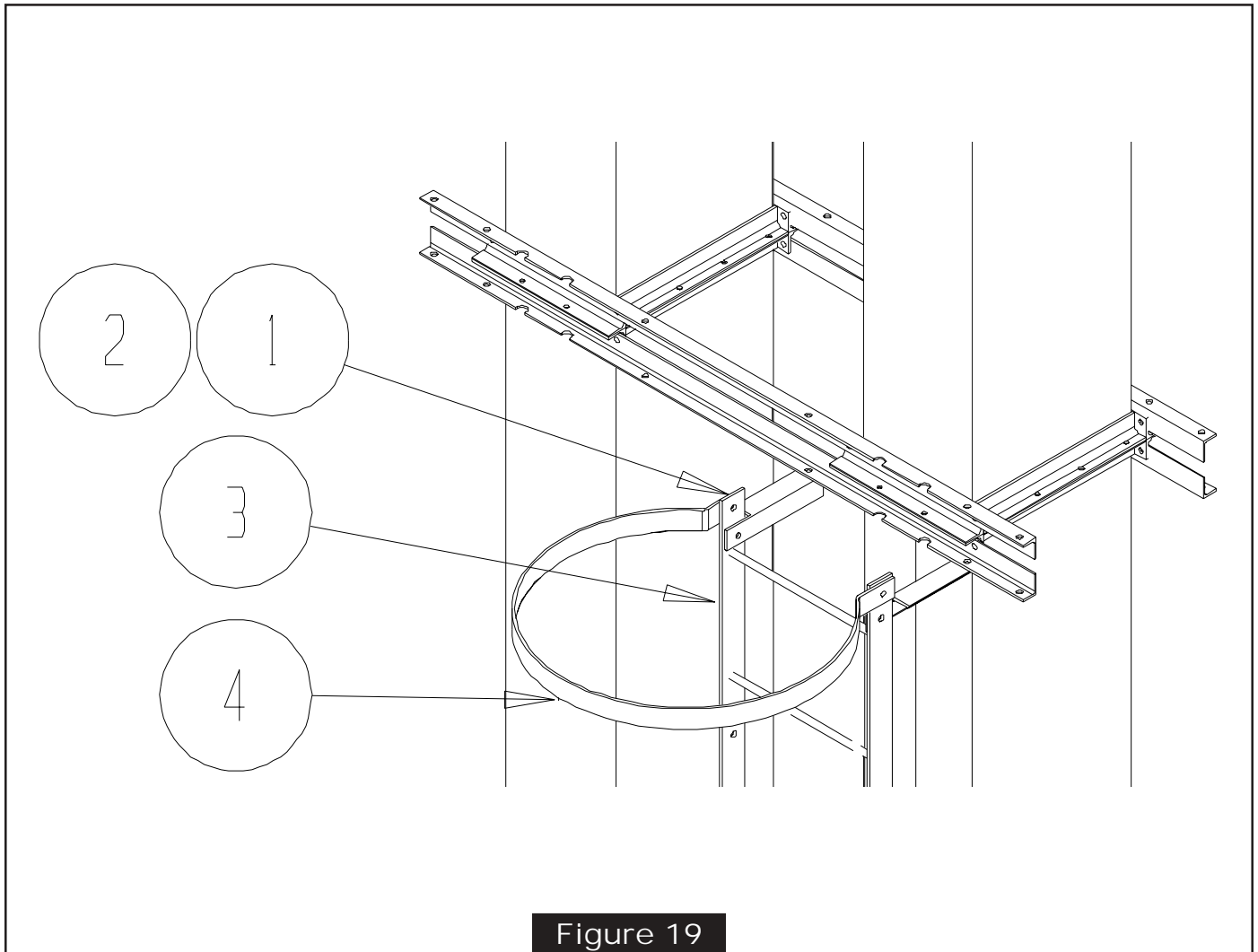
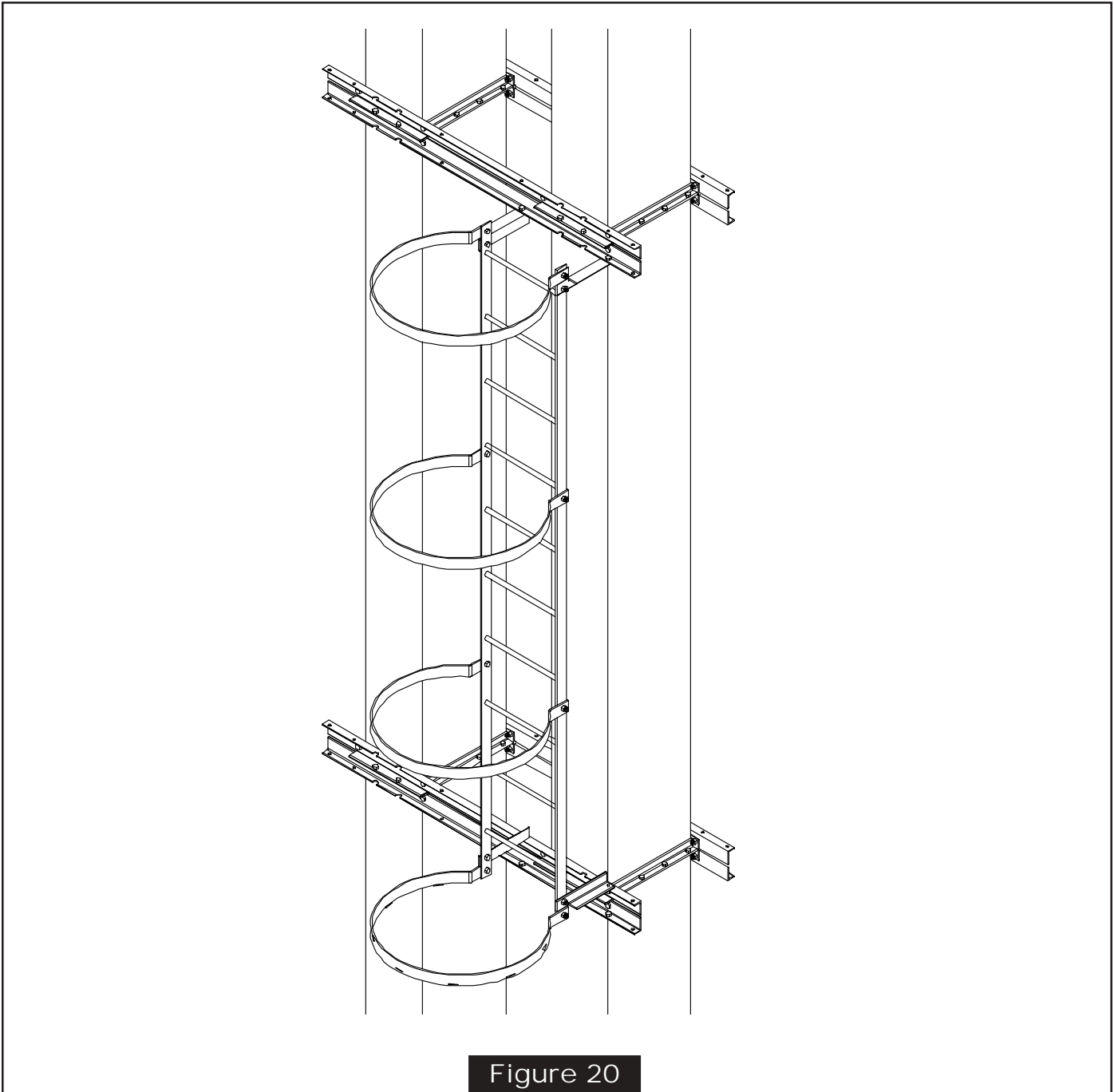

Figure 19

1. 1/2" - 13 x 1" Hex Bolt
2. 1/2" - 13 Hex Nut
3. 10' Ladder Section** (10foot)
4. 27" Safety Cage Hoop (27hoop)

Safety Cage Hoop Assembly

Bolt all safety cage hoops to ladder as shown below. Leave all bolts loose until the vertical bars are in place and then tighten all hardware.



Safety Cage Vertical Bar Attachment

Bolt all safety cage vertical bars to the cage hoops as shown below.

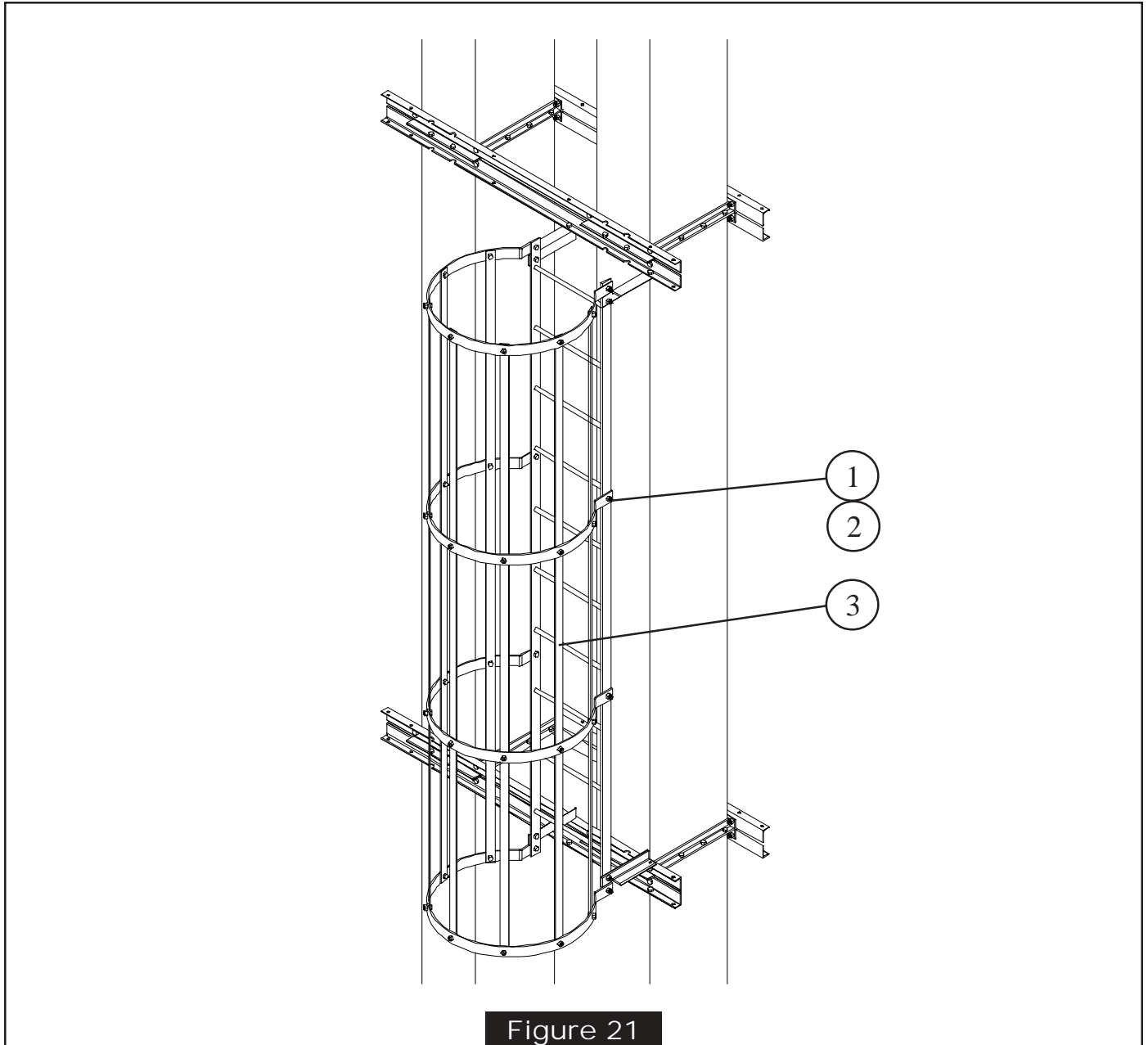

Figure 21

1. 1/2" - 13 x1" Hex Bolt
2. 1/2" - 13 Hex Nut
3. Safety Cage Vertical Bar (10foot-v)

Safety Cage Flare Attachment

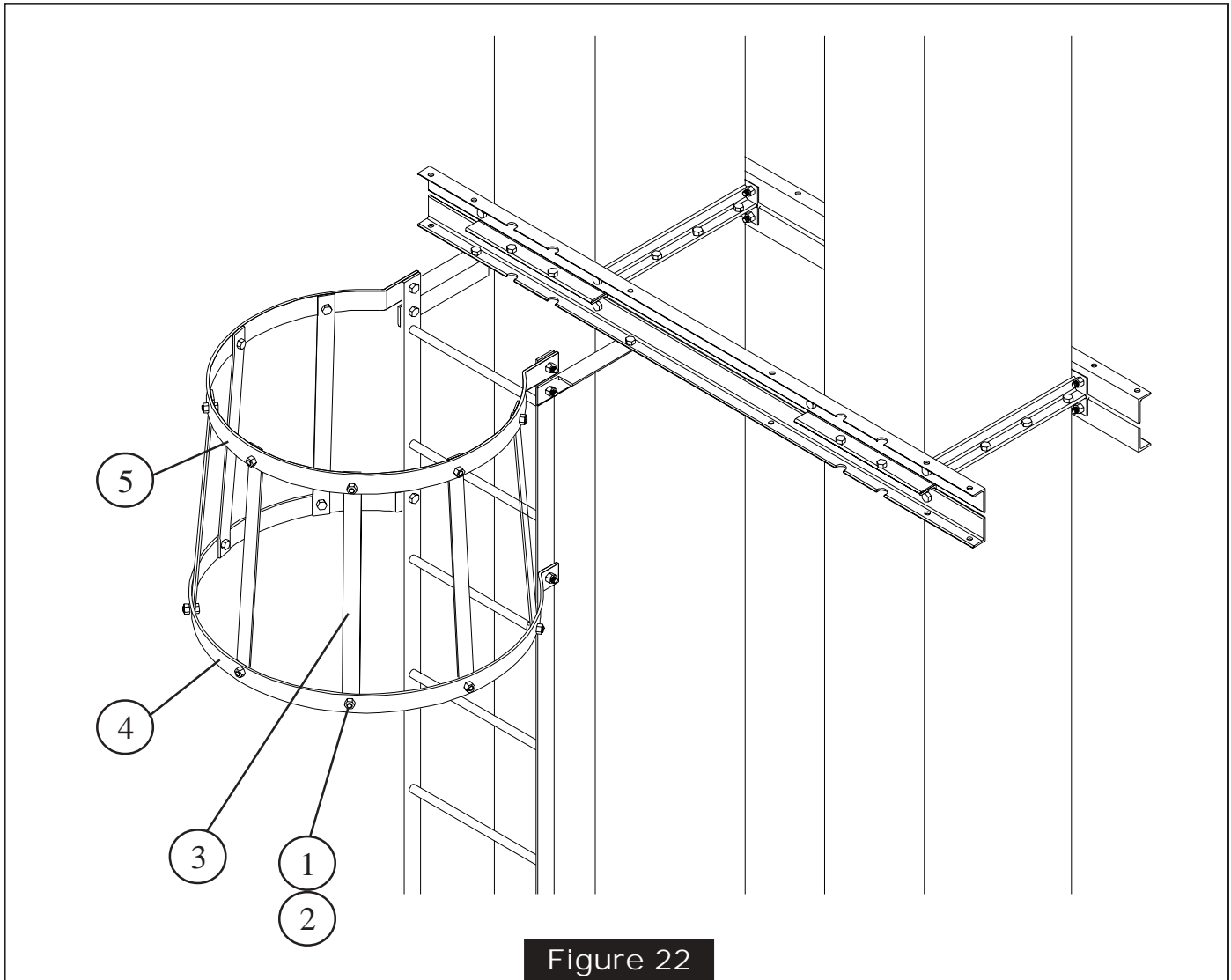

Figure 22

1. 1/2" - 13 x 1" Hex Bolt
2. 1/2" - 13 Hex Nut
3. Safety Cage Tapper Vertical Bar (taper-v)
4. 30" Safety Cage Hoop (30hoop)
5. 27" Safety Cage Hoop (27hoop)

REST PLATFORM ASSEMBLY

Side Mounting Channels

The first step to assemble the rest platform is to attach the side mounting channels to the tie angles. For 16" & 24" special, tie angles are in rest platform packages, (GECT 1640-RSP) and must be mounted in place of standard tie angles.

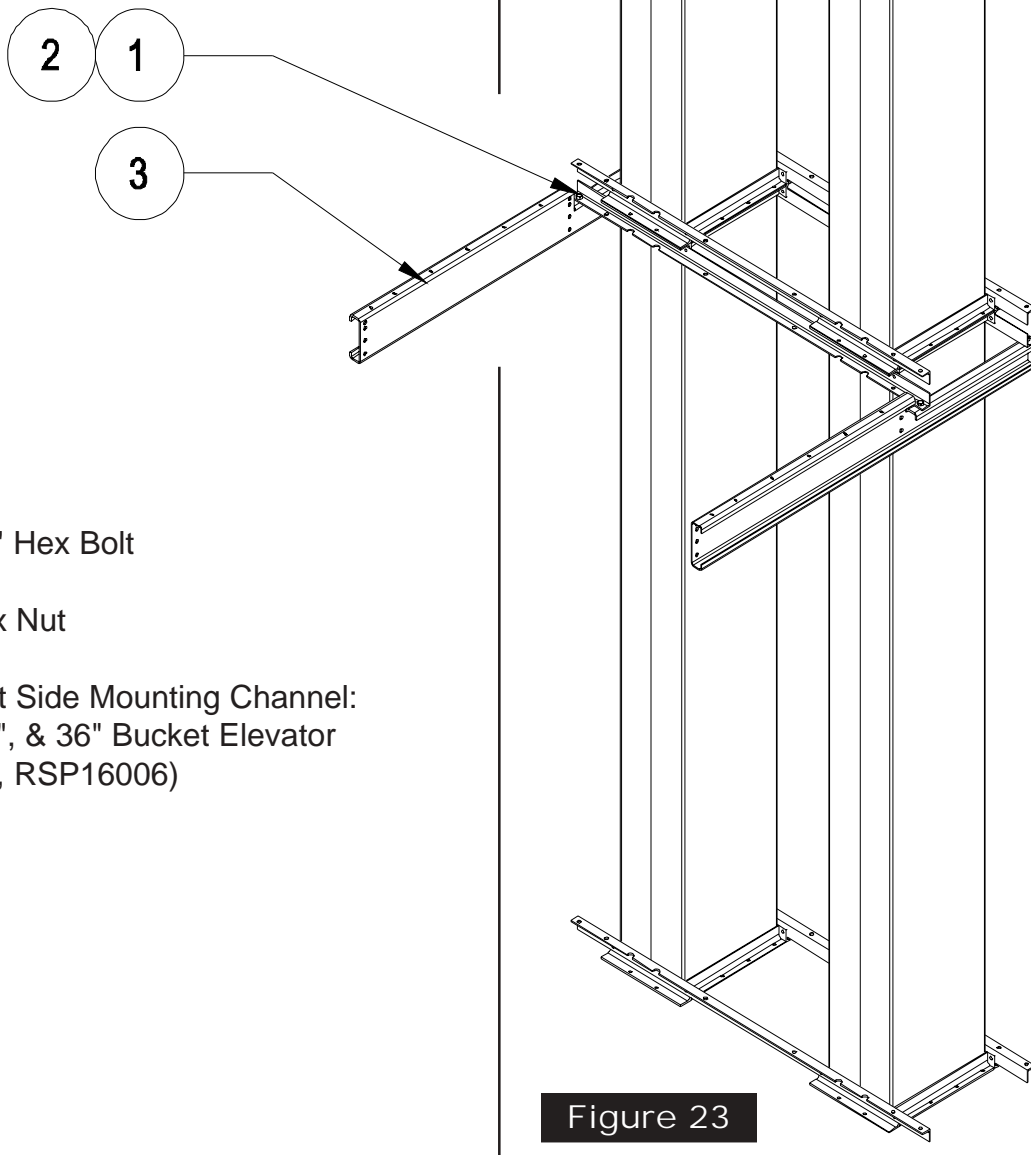

1. 1/2"-13 x 1" Hex Bolt
2. 1/2"-13 Hex Nut
3. Left & Right Side Mounting Channel:
16", 24", 30", & 36" Bucket Elevator
(RSP16005, RSP16006)

Figure 23

Platform Corner Post

Next attach the platform corner posts to the mounting channels as shown below. Leaving hardware loose will help fit other parts in place.

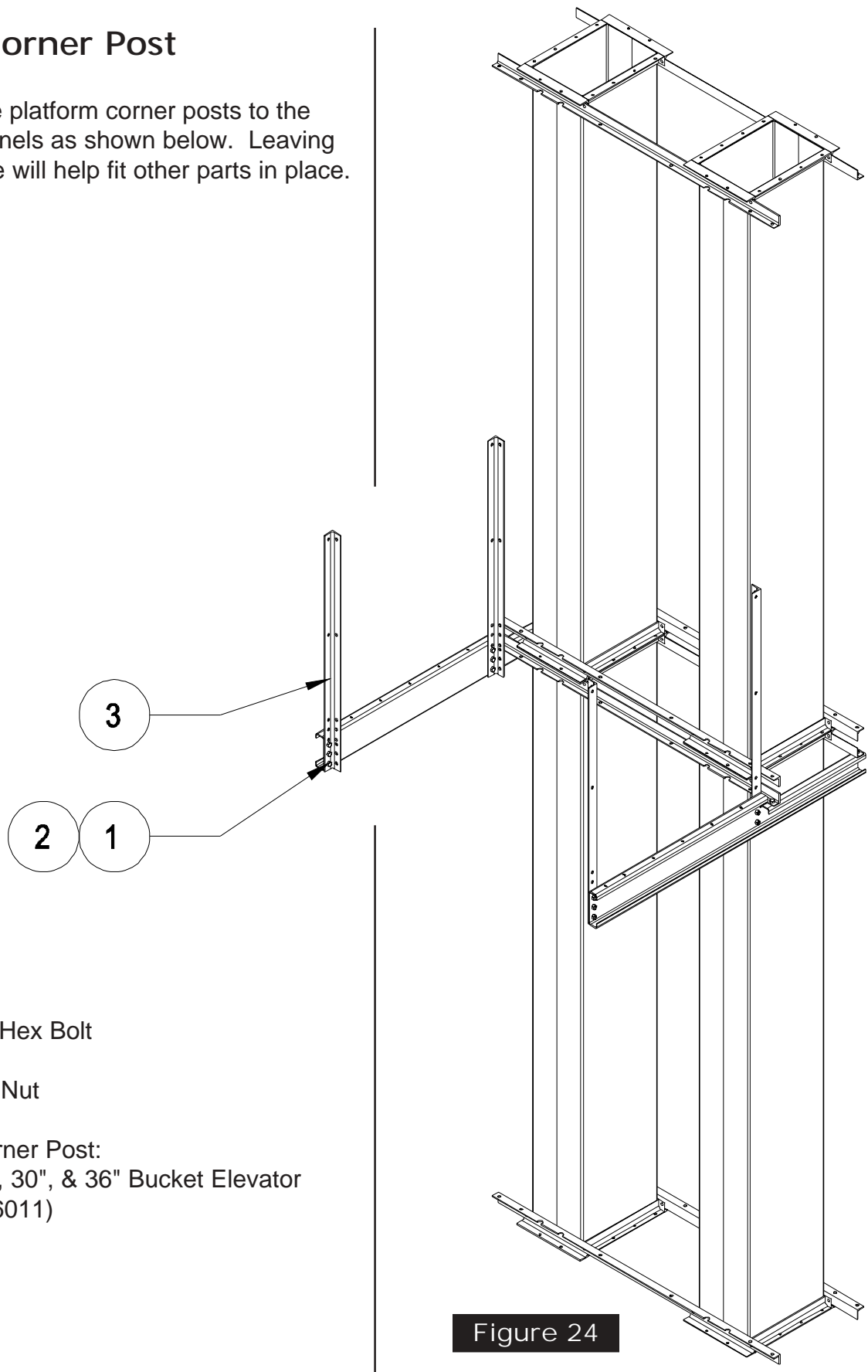

1. 3/8"-16 x 1" Hex Bolt
2. 3/8"-16 Hex Nut
3. Platform Corner Post:
16", 24", 30", & 36" Bucket Elevator
(RSP16011)

Figure 24

Front and Rear Mounting Channels

The next step is to attach the front and rear support channel to the platform corner posts as show below.

1. 3/8"-16 x 1" Hex Bolt
2. 3/8"-16 Hex Nut
3. Front Support Channel:
16", 24", 30", & 36" Bucket Elevator
RSP16007
See page 22, 23
4. Rear Mounting Channel:
16", 24", 30", & 36" Bucket Elevator
RSP16008

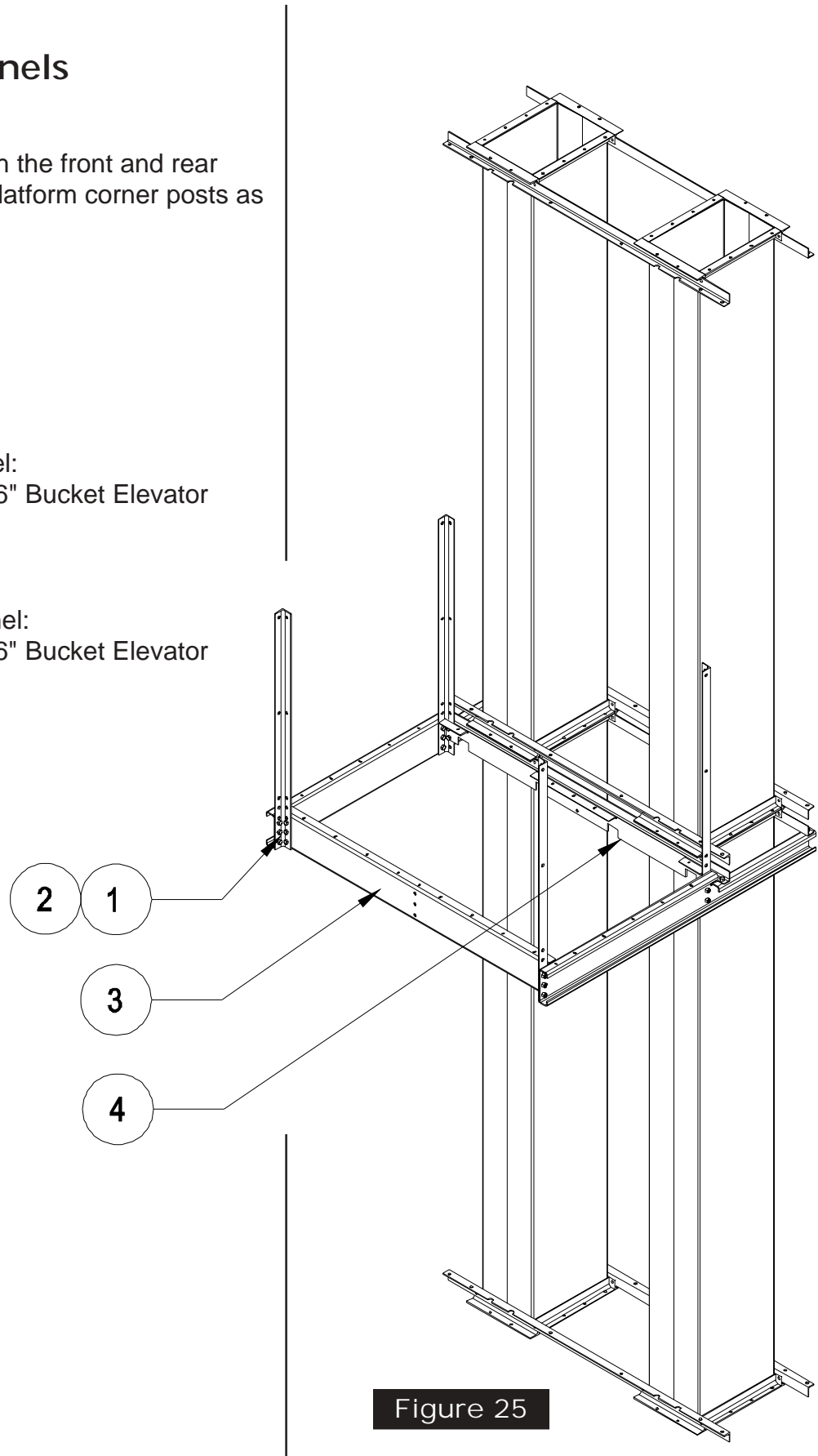

Figure 25

Center Support Channel

To complete the support frame, bolt on the center support channel to the front and rear support channel.

1. 3/8"-16 x 1" Hex Bolt
2. 3/8"-16 Hex Nut
3. Center Support Channel:**
16", 24", 30", & 36" Bucket Elevator
RSP16009

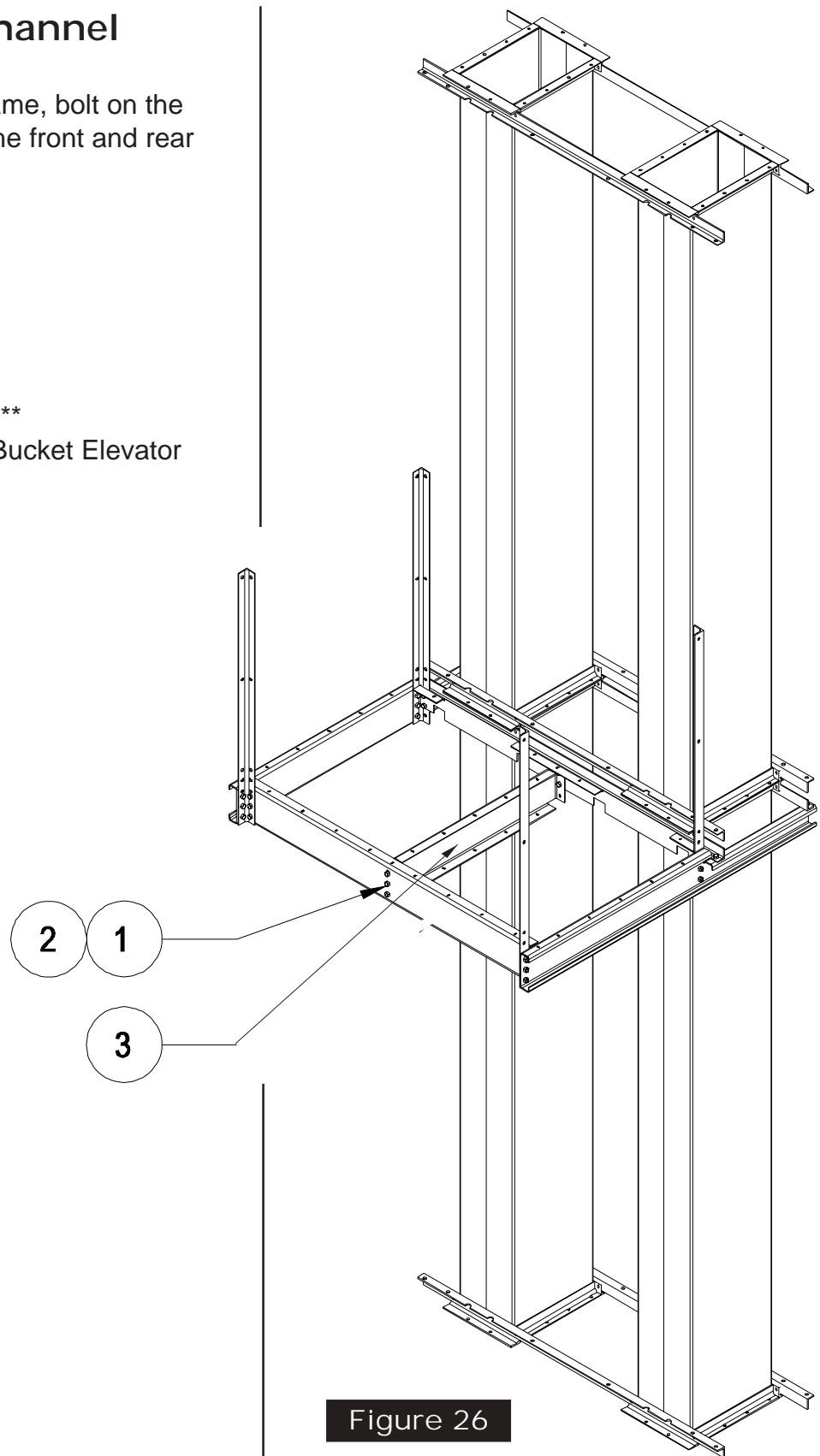
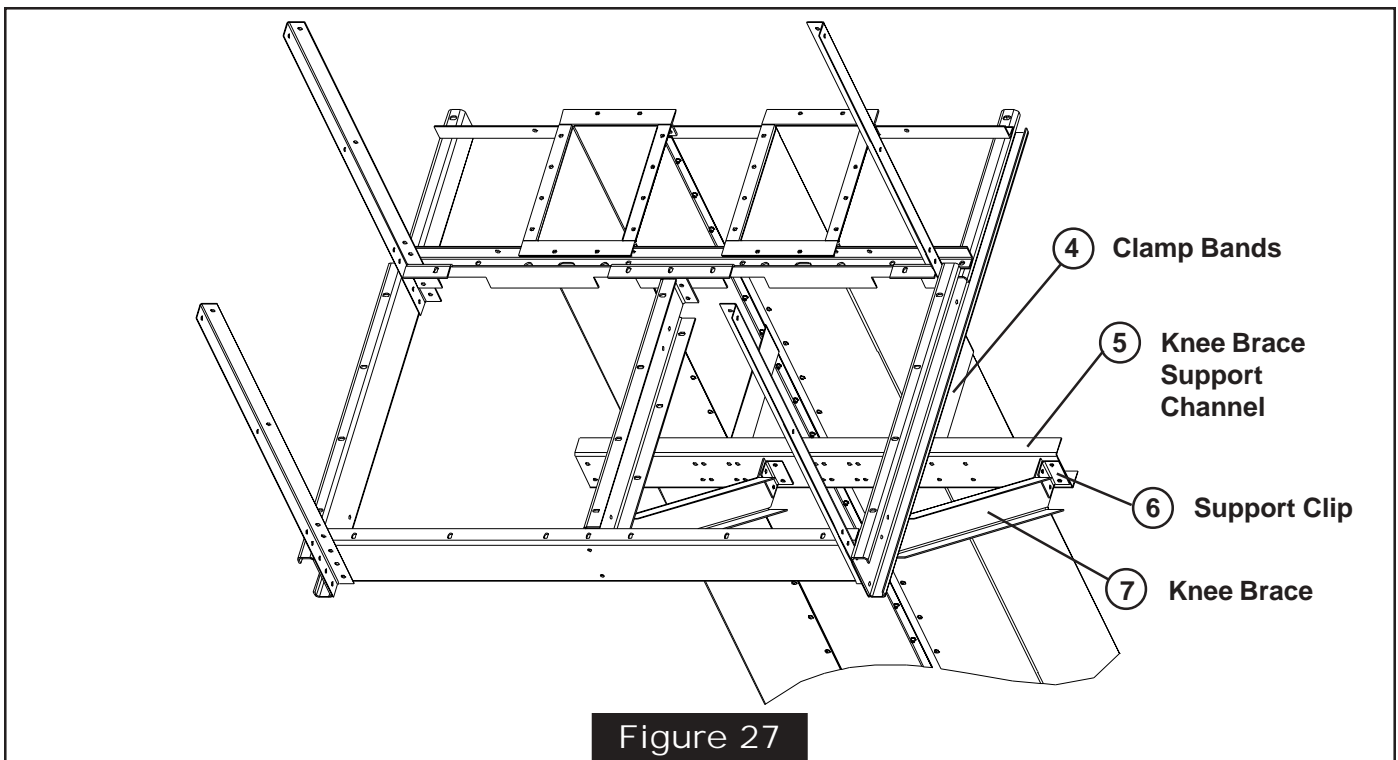

Figure 26

***This setup shows a left side step off. For a right side step off rotate the middle support channel and shift the floor plate.*

Knee Braces (16" & 24" Only)

16" and 24" legs need knee braces assembled to platform.



- | | |
|---|--|
| 1. Clamp Band Threaded Rod, 6" (RSP16017) | 5. Knee Brace Support Channel (RSP16001) |
| 2. 3/8"-16 Hex Nut | 6. Support Clip (RSP16004) |
| 3. 3/8"-16 x 1" Hex Bolt | 7. Knee Brace (RSP16003) |
| 4. Clamp Band Half (RSP16002) | |

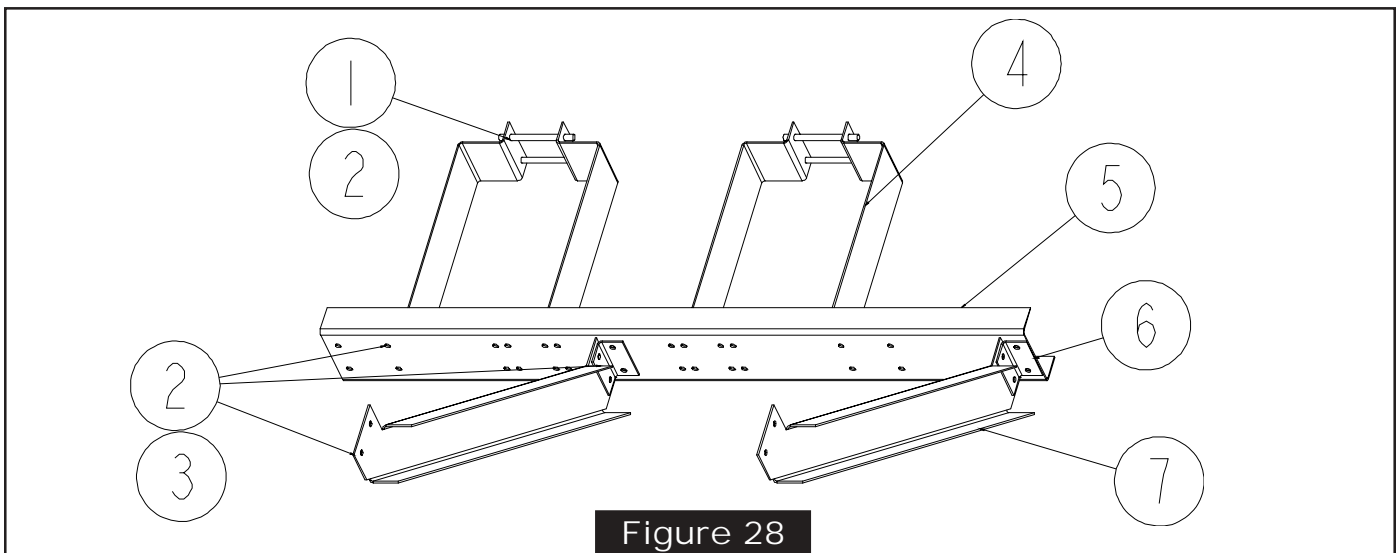

Rest Platform Deck Plate

Using the 3/8" hardware, bolt the deck plate to the mounting and support frames.

1. 3/8"-16 x 1" Hex Bolt
2. 3/8"-16 Hex Nut
3. 3/8" Flat Washer
4. Rest Platform Deck Plate:
16", 24", 30", & 36" Bucket Elevator
(RSP16010)

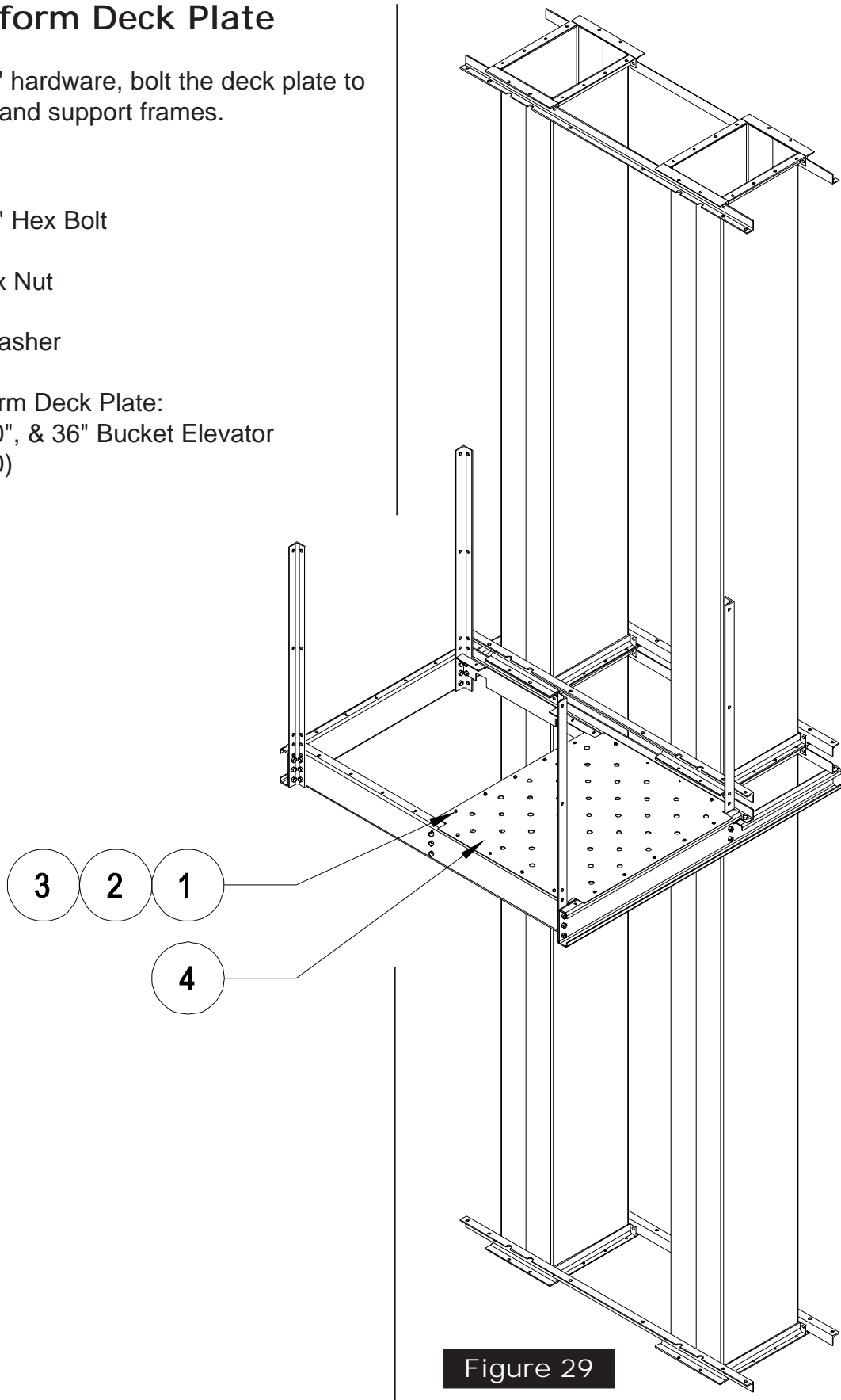
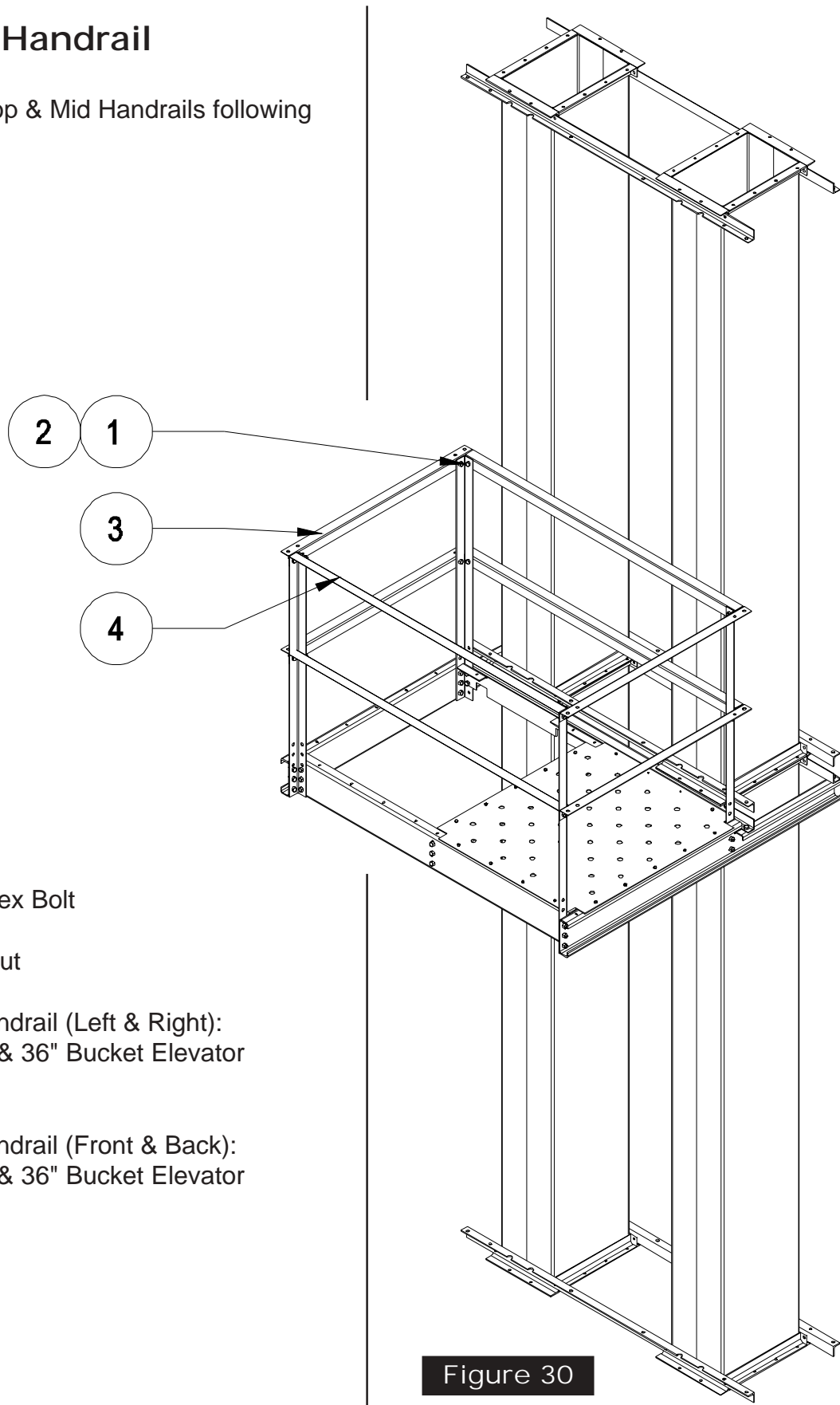

Figure 29

Top & Mid Handrail

Bolt on all the Top & Mid Handrails following picture below.



1. 3/8"-16 x 1" Hex Bolt
2. 3/8"-16 Hex Nut
3. Top & Mid Handrail (Left & Right):
16", 24", 30", & 36" Bucket Elevator
(RSP16012)
4. Top & Mid Handrail (Front & Back):
16", 24", 30", & 36" Bucket Elevator
(RSP16013)

Figure 30

Kickplates

To complete the rest platform, bolt on all toeboards to the platform corner posts.

Recheck all hardware to ensure proper tightness.

1. 3/8"-16 x 1" Hex Bolt
2. 3/8"-16 Hex Nut
3. 3/8"-16 x 1" Hex Bolt
4. 3/8"-16 x 1" Hex Nut

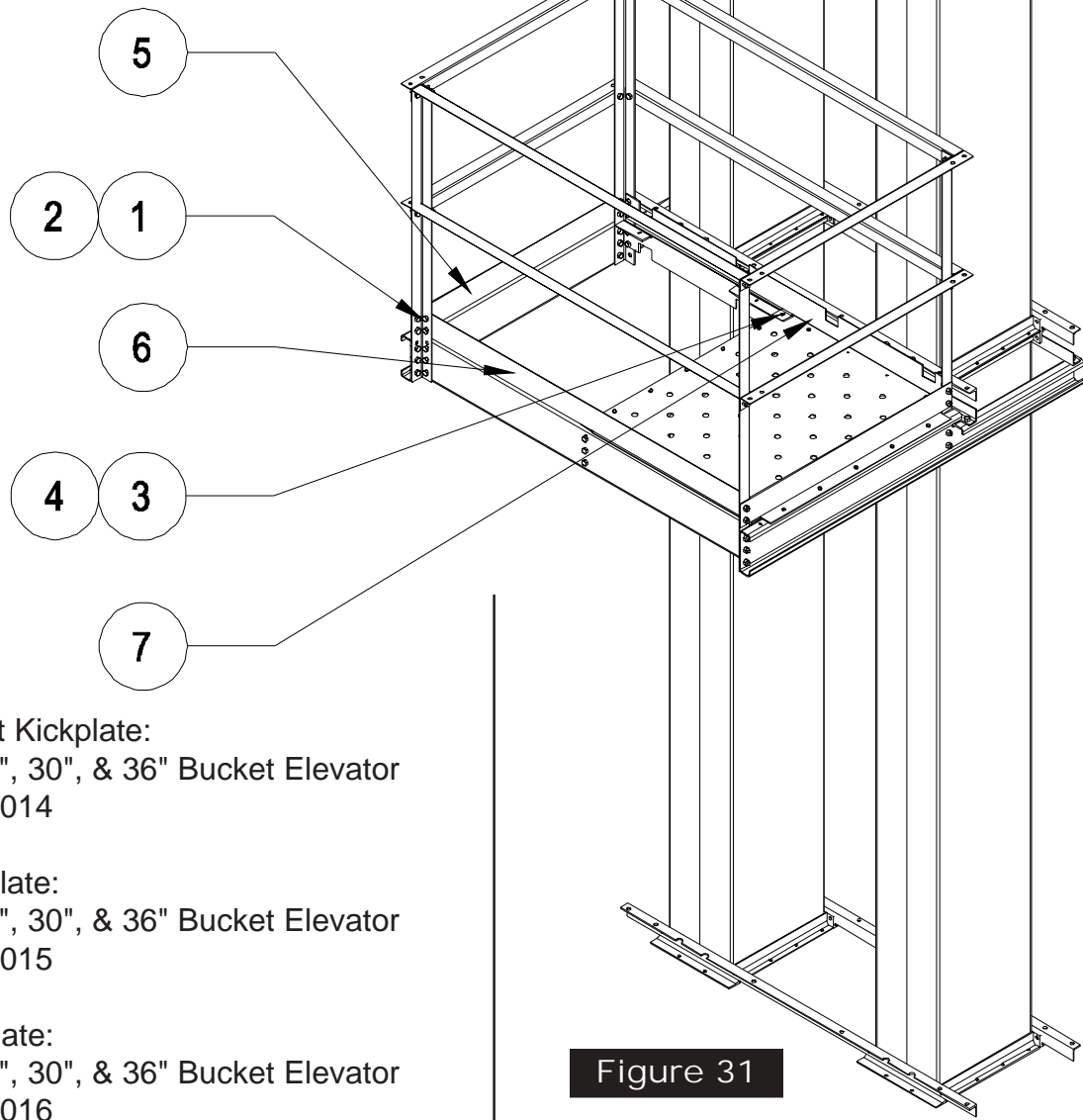

5. Left & Right Kickplate:
16", 24", 30", & 36" Bucket Elevator
RSP16014
6. Front Kickplate:
16", 24", 30", & 36" Bucket Elevator
RSP16015
7. Rear Kickplate:
16", 24", 30", & 36" Bucket Elevator
RSP16016

Figure 31

14' Ladder Assembly at Rest Platform

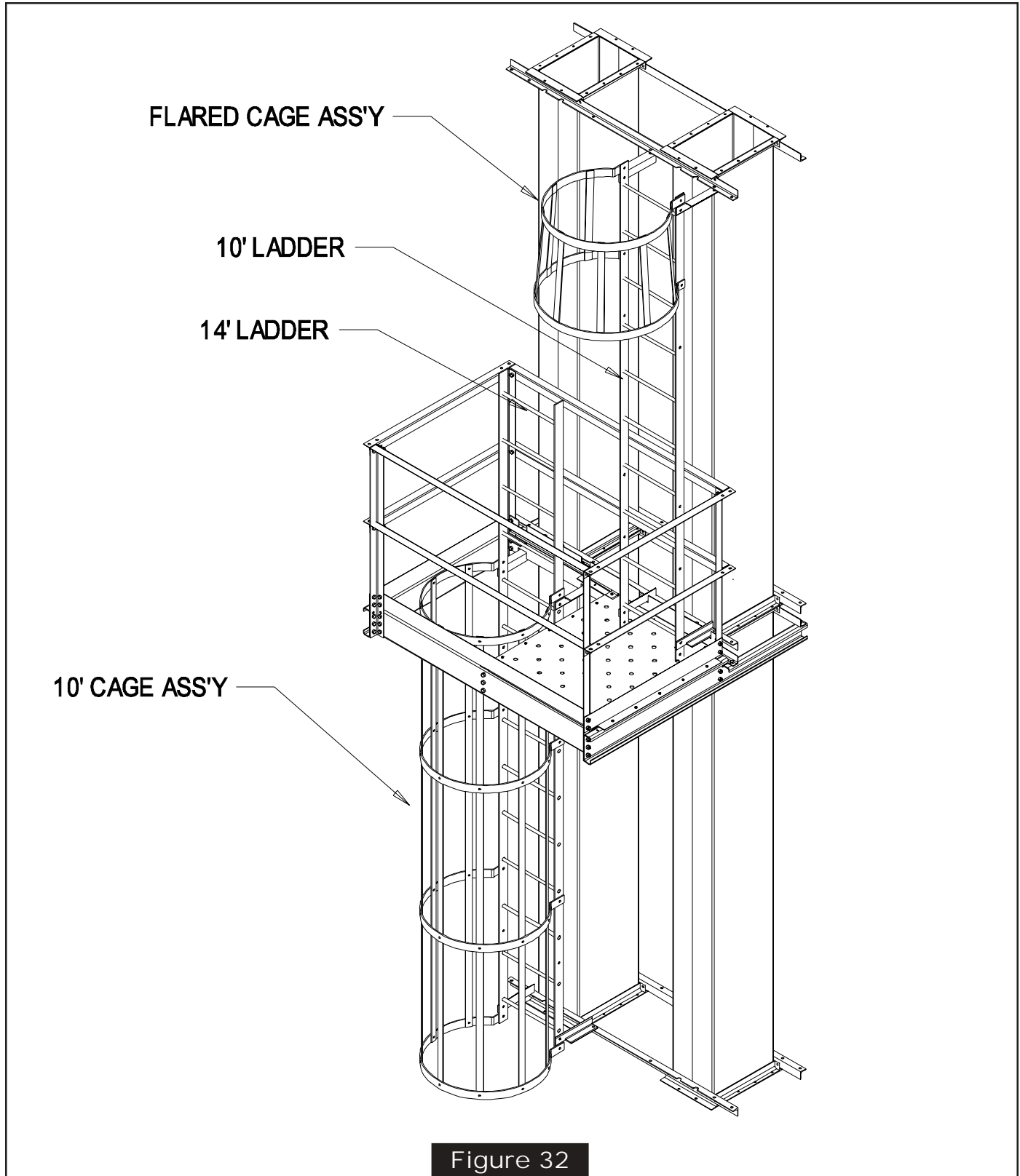

Platform Clamps

This assembly is designed to be located at any elevation on trunking that's needed to provide access to other equipment. Determine elevation of platform surface and work from there. Locate all parts required for assembly by using the charts shown in the following figures.

Locate all parts to assemble clamps onto the trunking. Measure the distance between the clamps to assure proper location for support channels and knee brace attachment. Attach a clamp half and support clip on one end of the

support channel using 1/2" hardware. Next attach the clamp rod weldment onto the clamp half using 1/2" nuts. Next place this assembly around trunk and attach other clamp half and support clip using 1/2" hardware.

NOTE: WHEN TIGHTENING CLAMPS ONTO TRUNKING, DO NOT OVERTIGHTEN AND COLLAPSE THE TRUNKING.

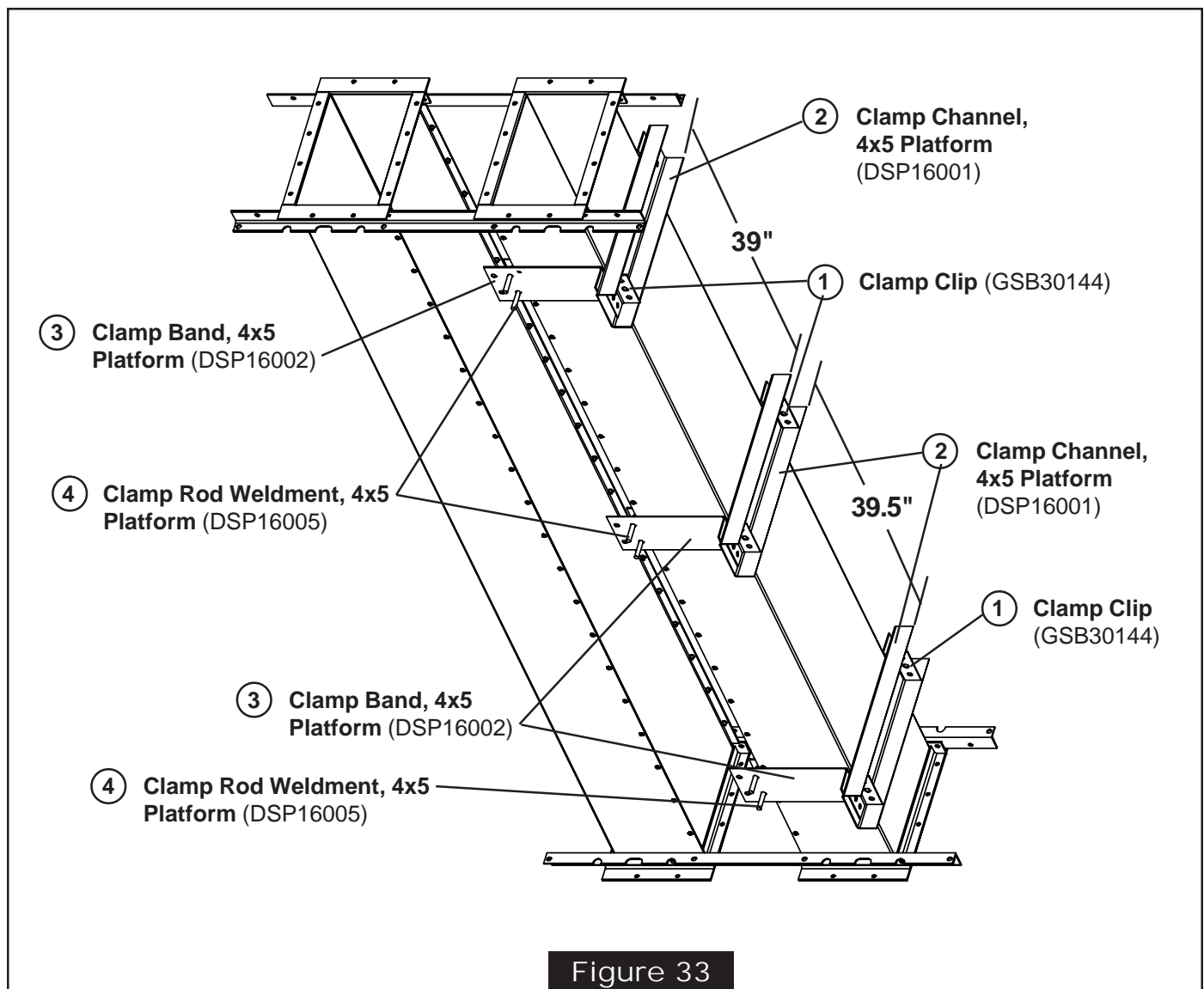

Support Channels & Knee Braces

With clamps fastened securely to the trunk, attach the platform support channels to the middle clamp, use 1/2" hardware with this assembly. The knee braces will attach in the upper set of holes on side of support channel

and to the lower clamp. Attach knee brace diagonals to bottom side of knee braces. Before tightening hardware the support channels must be perpendicular to the trunk, now tighten all hardware.

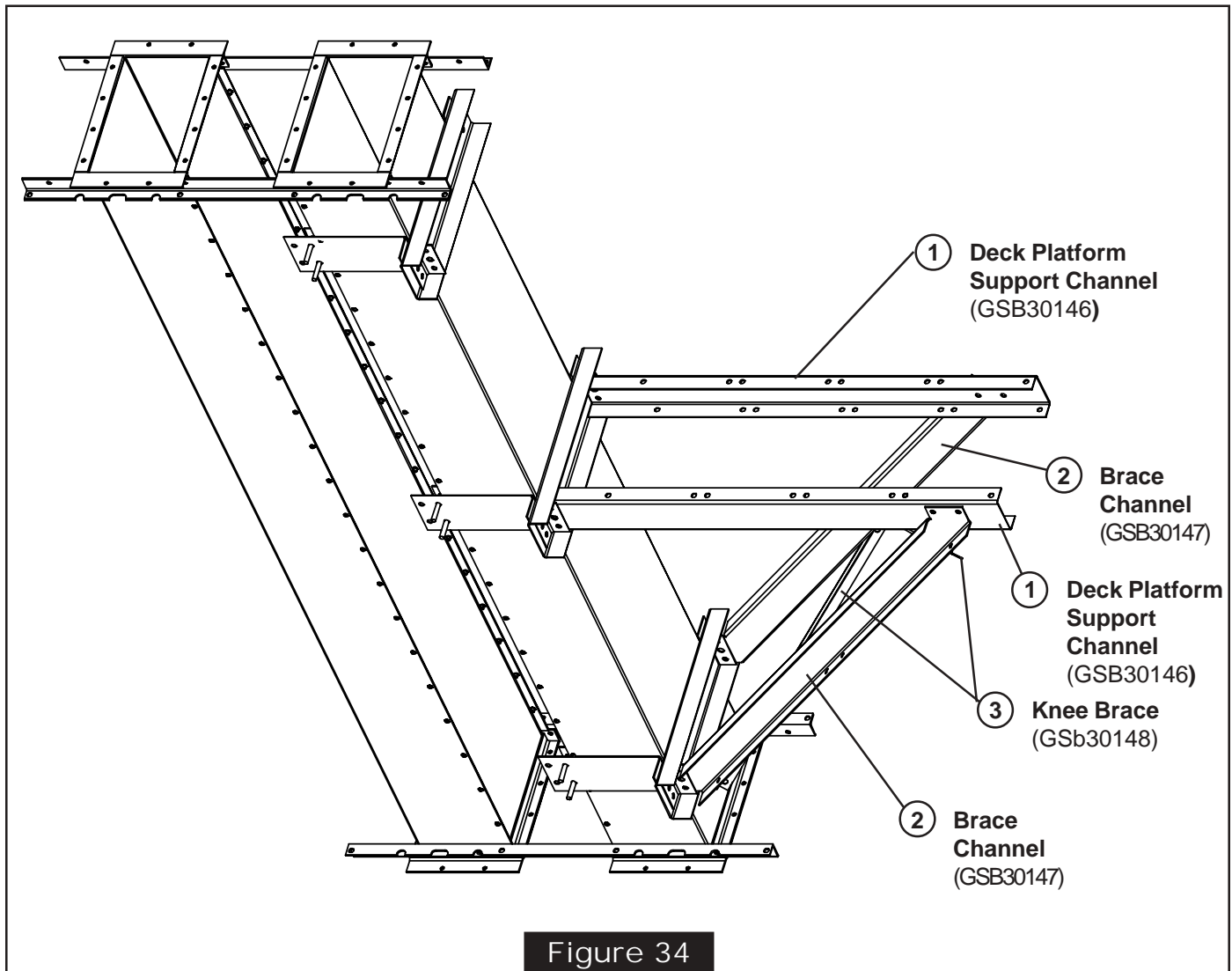
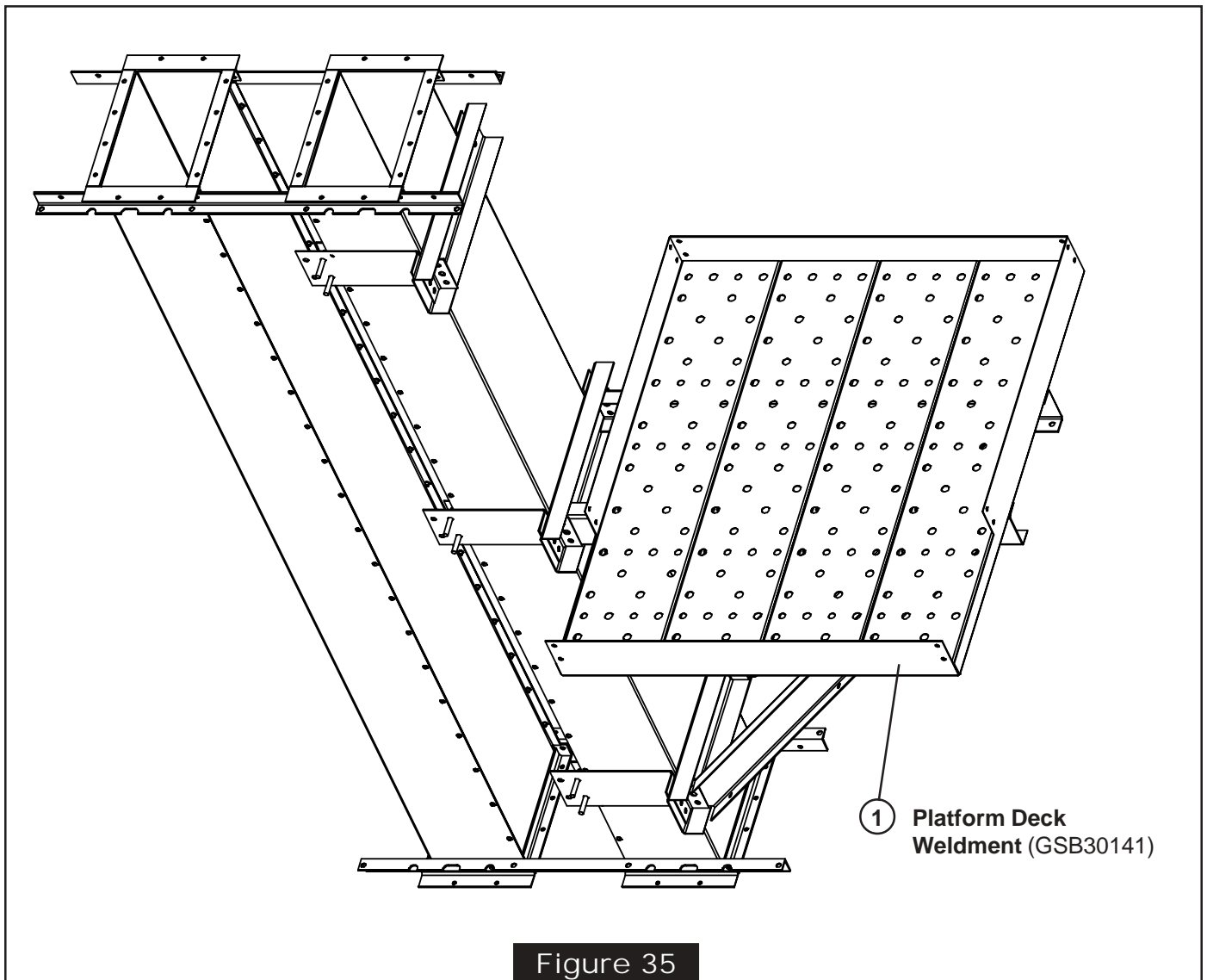

Figure 34

Platform Deck

With support assembly attached to trunk and hardware tightened, proceed with attaching floor deck weldment to the support channels using 1/2" hardware



Vertical Posts & Toeboard

Locate the toeboard cover plate and bolt over unused notched toeboard area using 3/8" hardware. Next attach all vertical posts in position shown with 3/8" hardware. Now bolt

the handrail brace plate to the vertical post as shown below. Make sure not to tighten hardware till handrail assembly is complete.

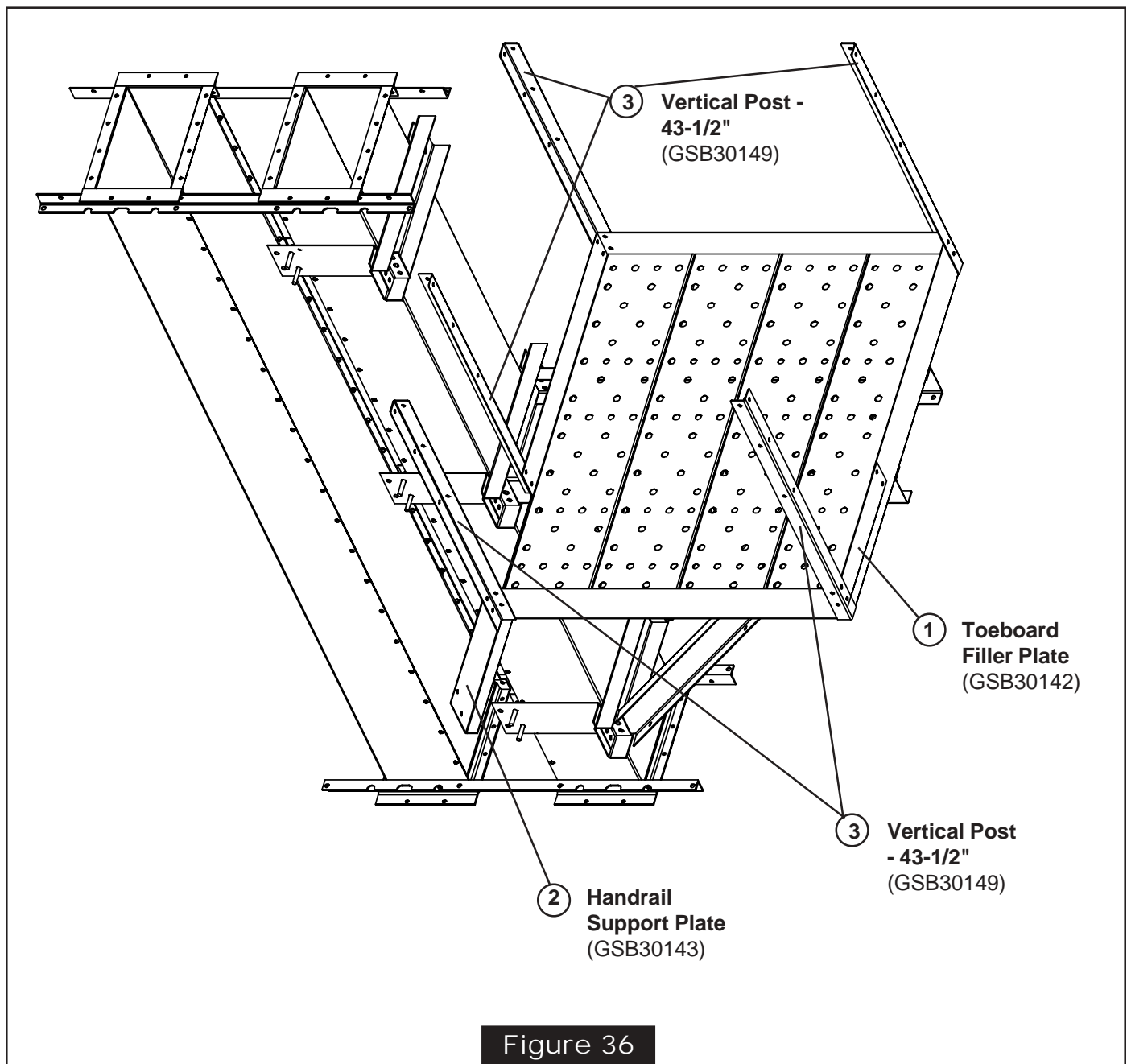

Handrail

Attach all handrails in position shown below using 3/8" hardware. Next attach handrail brace using 3/8" hardware. Now go back and tighten all hardware.

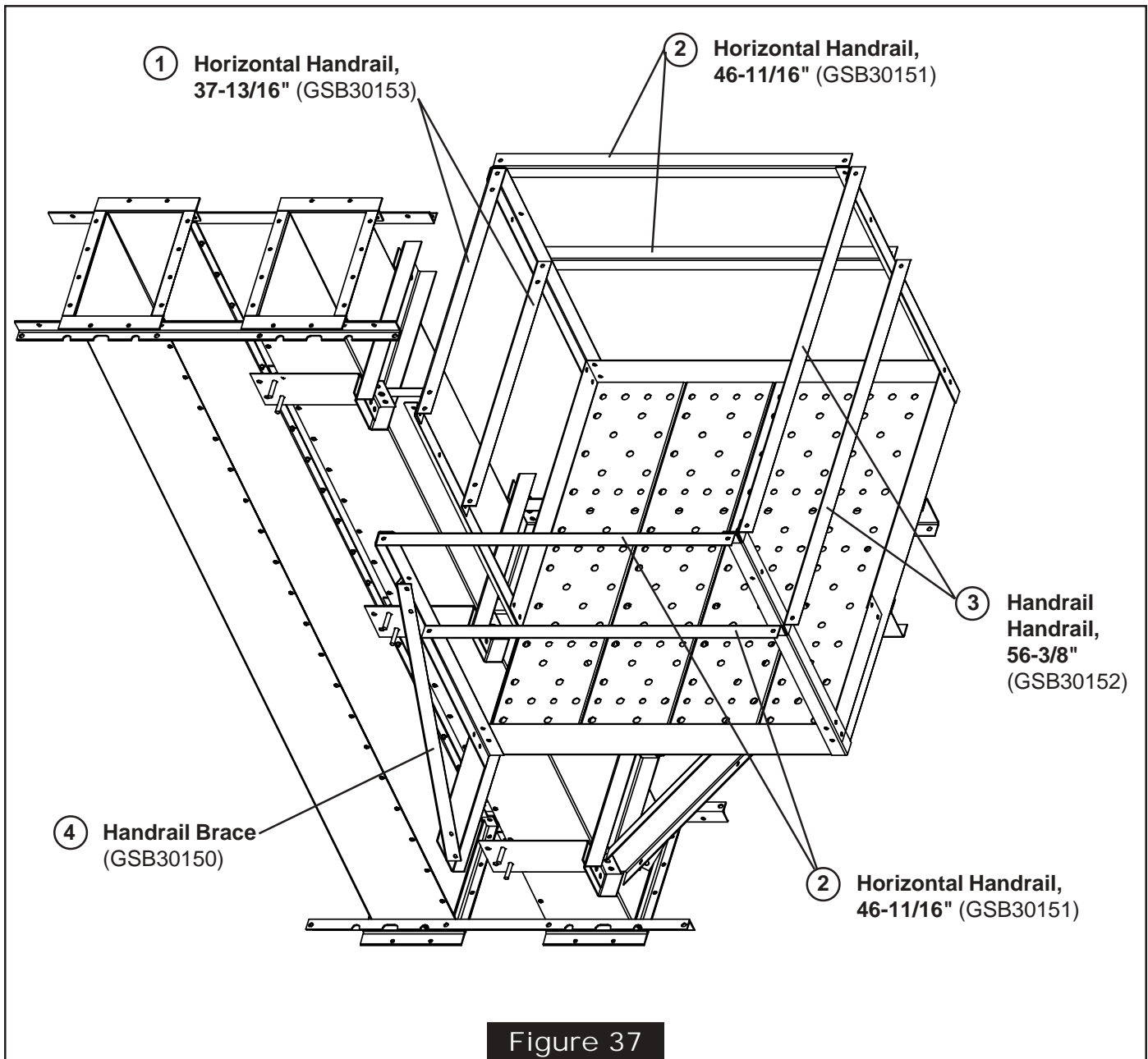

Platform Clamps

This assembly is designed to be located at any elevation on trunking that's needed to provide access to other equipment. Determine elevation of platform surface and work from there. Locate all parts required for assembly by using the charts shown in the following figures.

Locate all clamp halves, clamp brackets, threaded rods, and hardware to assemble clamps onto the trunking. Measure the distance between the clamps to assure proper location for support channels and knee brace attachment. See clamp detail for hardware orientation. Place 5/8" nuts and lock washers

on a threaded rod (one from each end). Place a clamp half on each end of the rod and thread another nut and lock washer to hold clamp in place. Now place that assembly around trunk and place a clamp bracket onto the opposite end of the clamp assembly and use 1/2" hardware to fasten parts together. Adjust the position of the inside nuts of the rod assembly to allow the clamps to be tightened onto the trunking.

NOTE: TIGHTEN CLAMPS ONTO TRUNKING, DO NOT OVERTIGHTEN AND COLLAPSE THE TRUNKING. Position inside nuts back to the clamp and tighten.

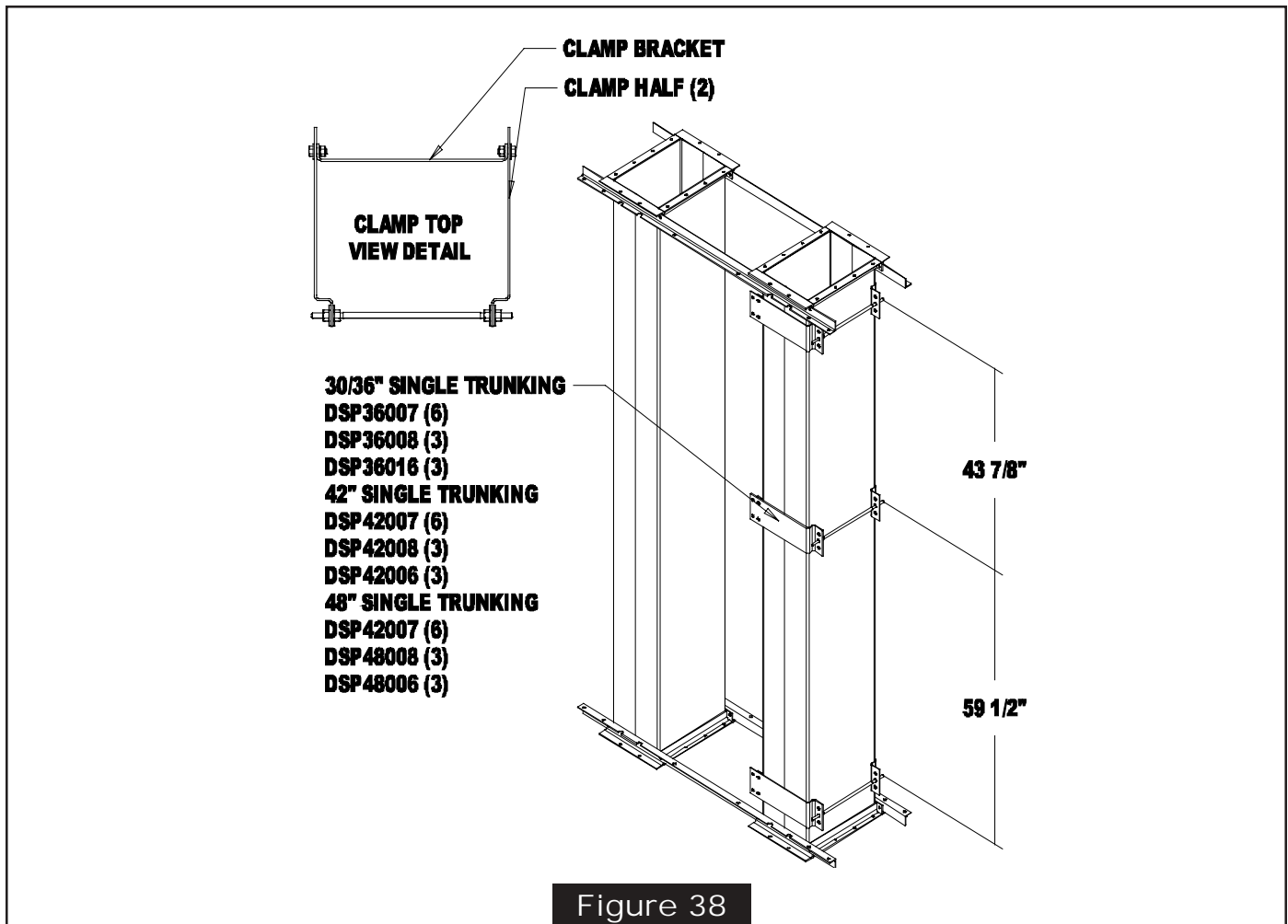

Support Channels & Knee Braces

With clamps fastened securely to the trunk, attach the platform support channels to the middle clamp, use 1/2" hardware with this assembly. The knee braces will attach in the upper set of holes on side of support channel and to the lower clamp. Before tightening

hardware the support channels must be perpendicular to the trunk, now tighten all hardware. The toeboards will not be centered on trunking but should be offset to the ladder side. The platform is designed to work for either side of trunking access.

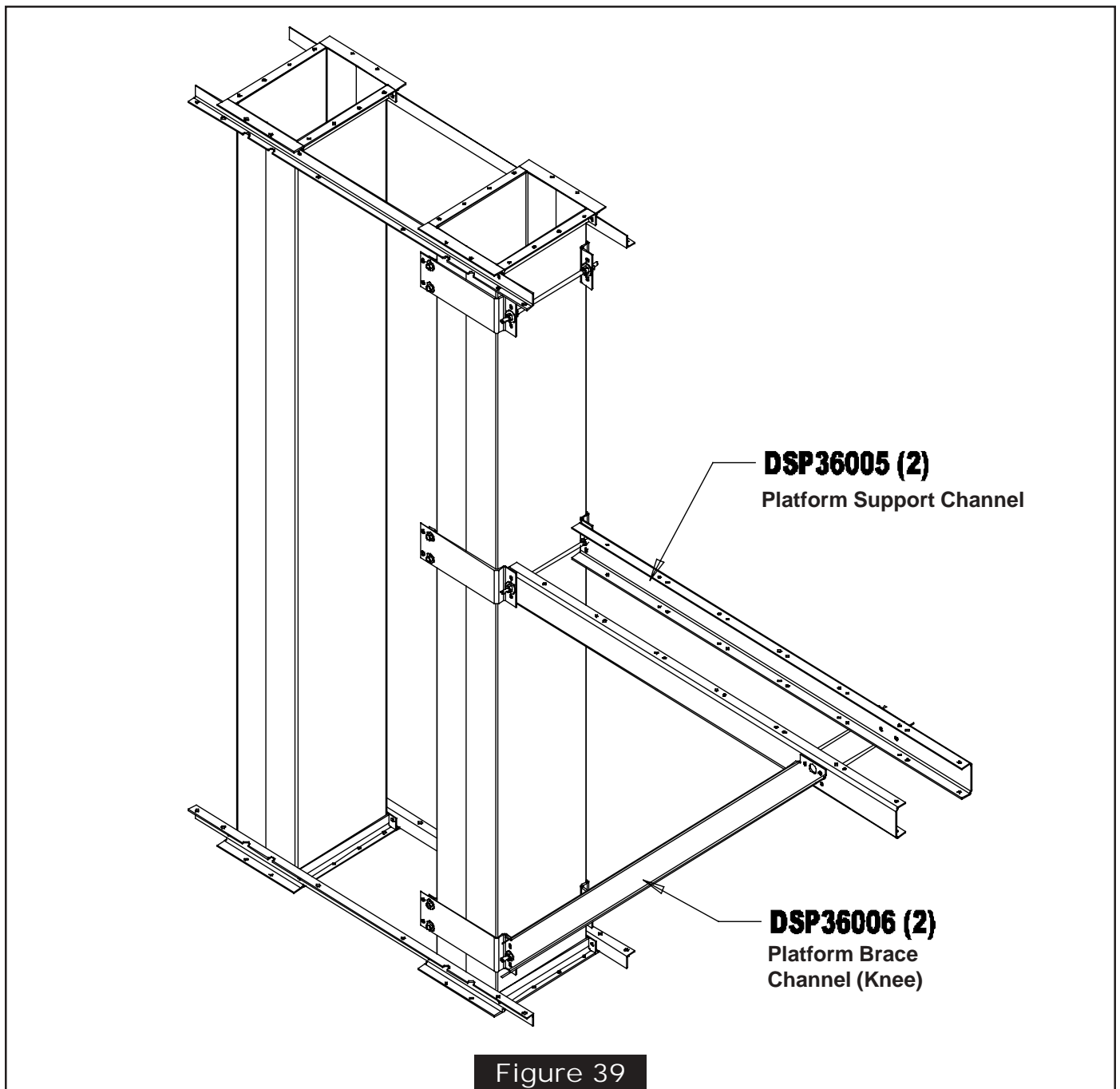

Toeboards

With support assembly attached to trunk and hardware tightened, proceed by attaching the notched toeboard and unnotched toeboard to

the top of the support channel using the 5/16" hardware provided. (Leave hardware loose). See Figure 40.

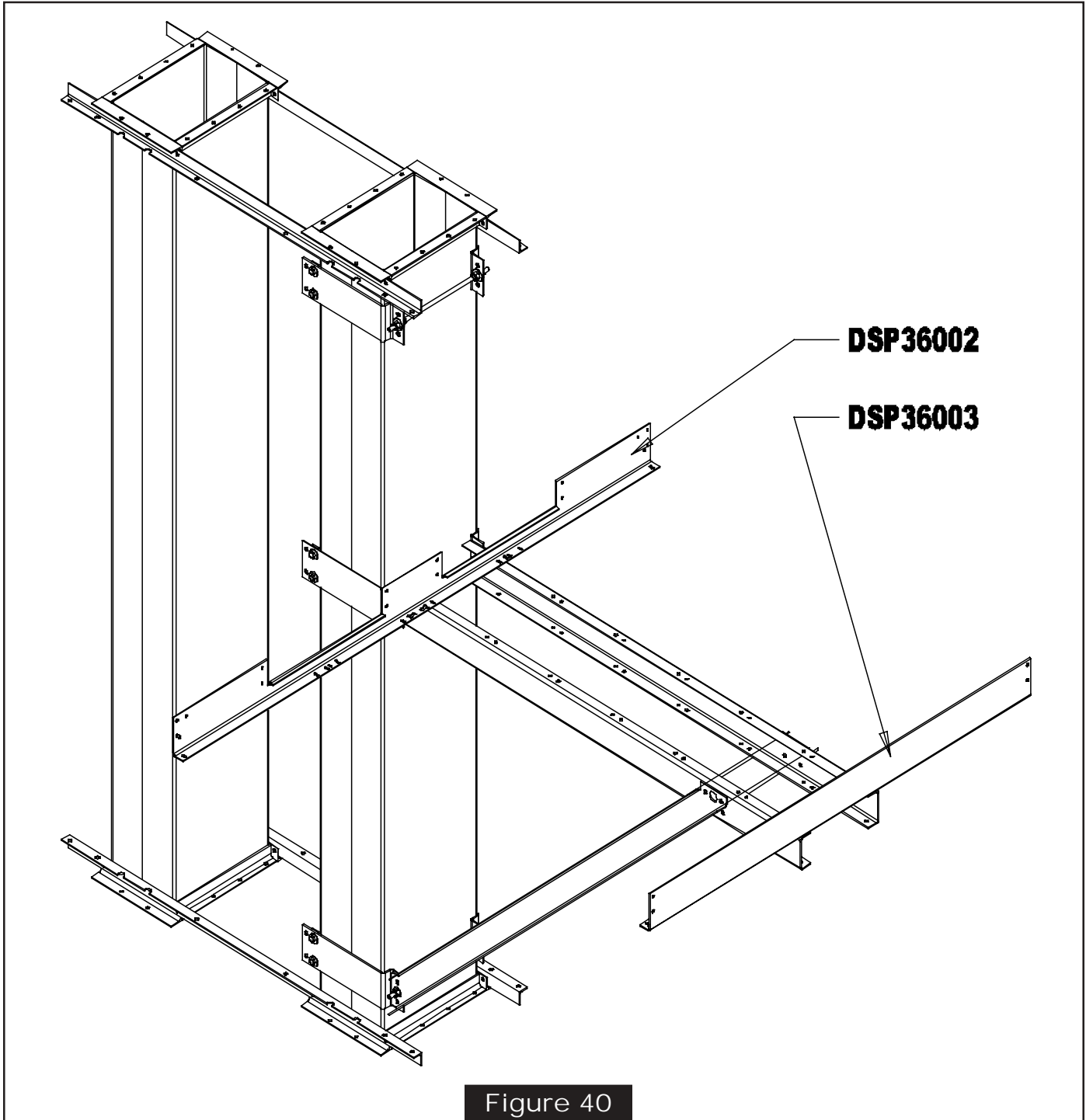

Platform Decking

Attach the floor deck panels to the support channels. Then attach end toeboards to the platform decking with the 5/16" hardware

provided. After all pieces have been attached and positioned properly, tighten all hardware.

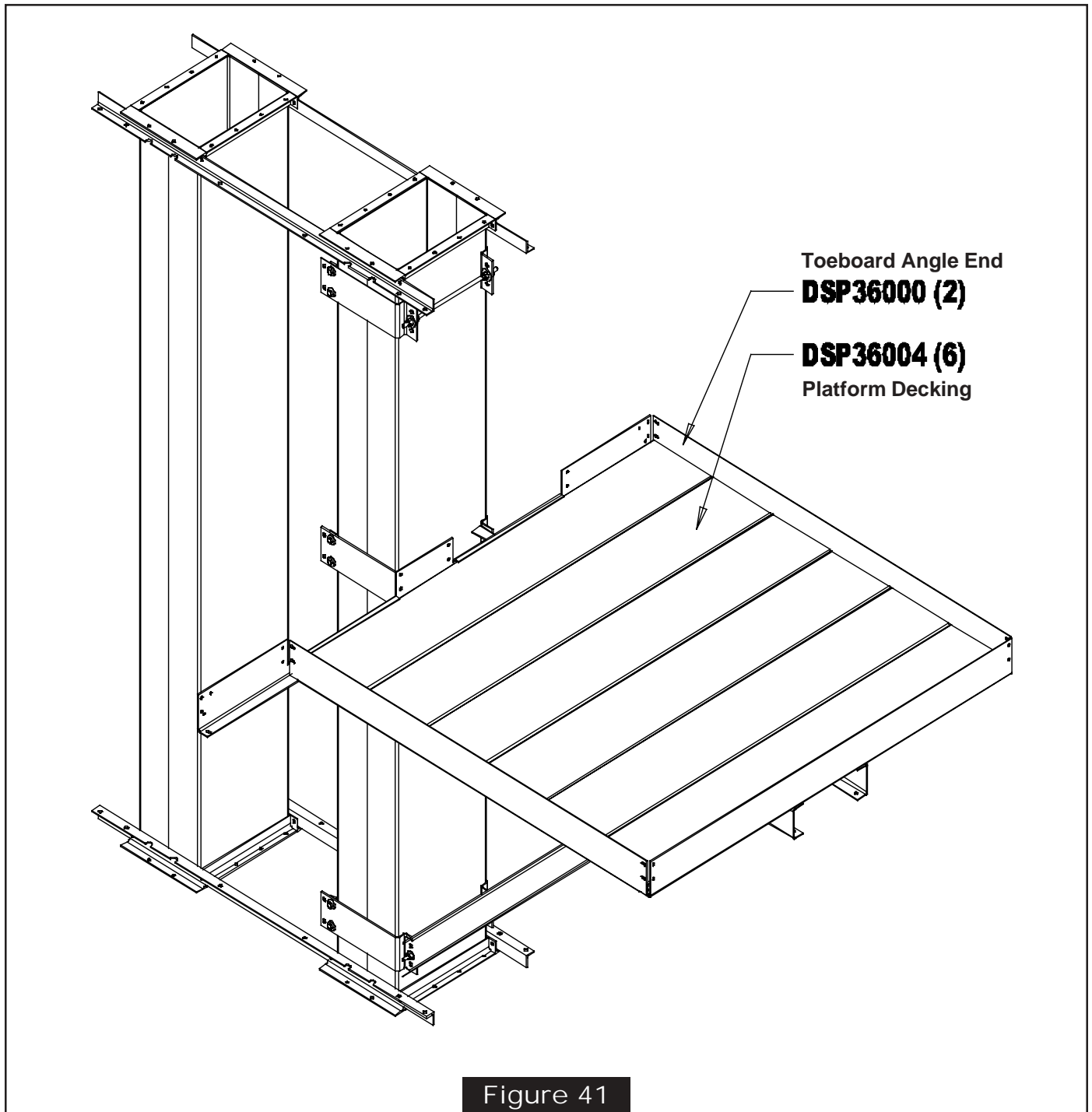

Handrails

Locate the toe board cover plate (DSP36001) and bolt over the unused notched toe board area. Attach handrail posts to the toe boards as shown using the 5/16" hardware provided. (Leave hardware loose until all handrails are in

place.) Attach all handrail angles and brace angle. See Figure 42. After all pieces have been attached go back and tighten all hardware. See Chart below for part numbers and lengths of all handrails.

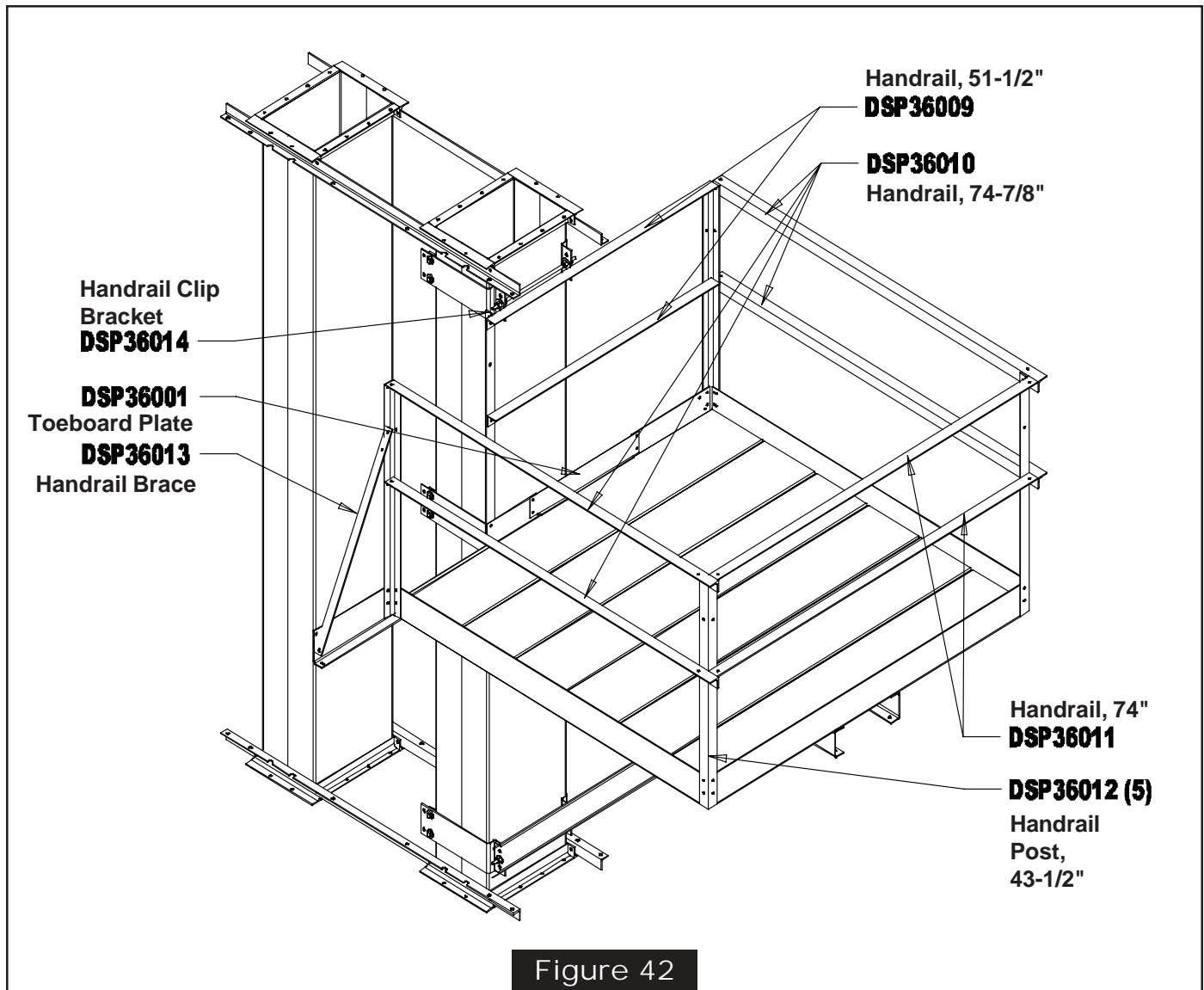
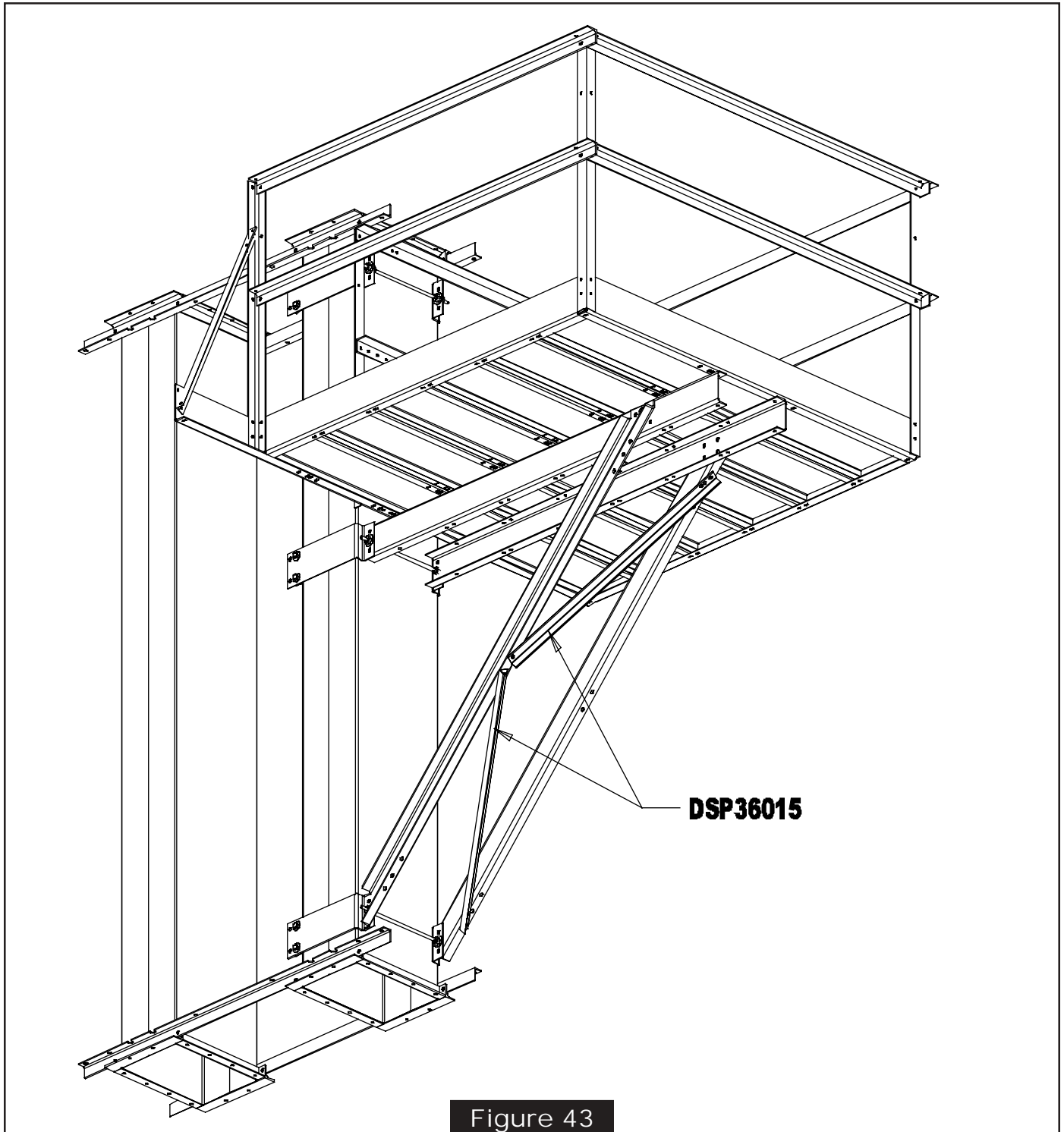

Figure 42

Model	Size
Handrail	DSP36009 - 51.1/2"
Handrail	DSP36010 - 74.7/8"
Handrail	DSP36011 - 74"
Post	DSP36012 - 43.1/2"
Brace	DSP36013 - 37.3/4"

Crossbraces for Knee Braces

Attach knee brace diagonals to bottom side of the knee braces, this will add extra stability to the distributor platform. See Figure 43.



NOTES

WARRANTY

THE COMPANY WARRANTS ALL PRODUCTS MANUFACTURED TO BE FREE OF DEFECTS IN MATERIAL AND WORKMANSHIP UNDER NORMAL USAGE AND CONDITIONS FOR A PERIOD OF TWELVE (12) MONTHS AFTER RETAIL SALE TO THE ORIGINAL END USER OF SUCH PRODUCTS. OUR ONLY OBLIGATION IS, AND PURCHASER'S SOLE REMEDY SHALL BE TO REPAIR OR REPLACE, AT THE COMPANY'S OPTION AND EXPENSE, PRODUCTS THAT, IN THE MANUFACTURERS SOLE JUDGEMENT, CONTAIN A MATERIAL DEFECT DUE TO MATERIALS OR WORKMANSHIP. ALL DELIVERY AND SHIPMENT CHARGES TO AND FROM THE FACTORY WILL BE PURCHASER'S RESPONSIBILITY. EXPENSES INCURRED BY OR ON BEHALF OF THE PURCHASER WITHOUT PRIOR WRITTEN AUTHORIZATION FROM AN AUTHORIZED EMPLOYEE OF THE COMPANY SHALL BE THE SOLE RESPONSIBILITY OF THE PURCHASER.

EXCEPT FOR THE ABOVE EXPRESS LIMITED WARRANTIES, THE COMPANY MAKES NO WARRANTY OF ANY KIND, EXPRESSED OR IMPLIED, INCLUDING, WITHOUT LIMITATION, WARRANTIES OF MERCHANTABILITY OR FITNESS FOR A PARTICULAR PURPOSE OR USE IN CONNECTION WITH (i) PRODUCT MANUFACTURED OR SOLD BY THE COMPANY OR (ii) ANY ADVICE, INSTRUCTION, RECOMMENDATION OR SUGGESTION PROVIDED BY AN AGENT, REPRESENTATIVE OR EMPLOYEE OF THE COMPANY REGARDING OR RELATED TO THE CONFIGURATION, INSTALLATION, LAYOUT, SUITABILITY FOR A PARTICULAR PURPOSE, OR DESIGN OF SUCH PRODUCT OR PRODUCTS.

IN NO EVENT SHALL THE COMPANY BE LIABLE FOR ANY DIRECT, INDIRECT, INCIDENTAL, OR CONSEQUENTIAL DAMAGES, INCLUDING, WITHOUT LIMITATION, LOSS OF ANTICIPATED PROFITS OR BENEFITS. PURCHASER'S SOLE AND EXCLUSIVE REMEDY SHALL BE LIMITED TO THAT STATED ABOVE, WHICH SHALL NOT EXCEED THE AMOUNT PAID FOR THE PRODUCT PURCHASED. THIS WARRANTY IS NOT TRANSFERABLE AND APPLIES ONLY TO THE ORIGINAL PURCHASER. WE SHALL HAVE NO OBLIGATION OR RESPONSIBILITY FOR ANY REPRESENTATIVE OR WARRANTIES MADE BY OR ON BEHALF OF ANY DEALER, AGENT OR DISTRIBUTOR OF THE COMPANY.

THE COMPANY ASSUMES NO RESPONSIBILITY FOR FIELD MODIFICATIONS. MODIFICATIONS TO THE PRODUCT NOT SPECIFICALLY COVERED BY THE CONTENTS OF THIS MANUAL WILL NULLIFY ANY PRODUCT WARRANTY THAT MIGHT HAVE BEEN OTHERWISE AVAILABLE. THE USE OF OUR EQUIPMENT TO HANDLE MATERIALS OTHER THAN FREE FLOWING, NONABRASIVE AND DRY MATERIALS, AS INTENDED, WILL RESULT IN THE VOIDING OF THIS LIMITED WARRANTY.

THE FOREGOING WARRANTY SHALL NOT COVER PRODUCTS OR PARTS WHICH HAVE BEEN DAMAGED BY NEGLIGENT USE, MISUSE, ALTERATION, OR ACCIDENT. ANY NEGLIGENT USE, MISUSE, ALTERATION, OR DAMAGE DUE TO ACCIDENT, AS DETERMINED BY A COMPANY REPRESENTATIVE, MAY VOID THE WARRANTY. THIS WARRANTY COVERS ONLY PRODUCTS MANUFACTURED BY THE COMPANY. THIS WARRANTY IS EXCLUSIVE AND IN LIEU OF ALL OTHER WARRANTIES EXPRESS OR IMPLIED. WE RESERVES THE RIGHT TO MAKE DESIGN OR SPECIFICATION CHANGES AT ANY TIME, BEARING NO RESPONSIBILITY TO MAKE SIMILAR DESIGN OR SPECIFICATION CHANGES ON PREVIOUSLY SOLD MERCHANDISE.

PRIOR TO INSTALLATION, PURCHASER HAS THE RESPONSIBILITY TO RESEARCH AND COMPLY WITH ALL FEDERAL, STATE, AND LOCAL CODES WHICH MAY APPLY TO THE LOCATION AND INSTALLATION.

This Equipment shall be installed in accordance with the current installation codes and applicable regulations which should be carefully followed in all cases. Authorities having jurisdiction should be consulted before installation occurs.



**1004 East Illinois Street
Assumption, IL 62510
217-226-4421 Phone**
